

## 编译者说明

由于电子工业和电影、电视事业的飞速发展，近年来，我国在光学镜头设计及加工方面取得了很大进展。成系列的各类镜头已经设计和试制出来，有些并已进入成批生产阶段。但在品种、数量和质量方面，跟世界先进水平相比，差距还是比较大。

近年来，我们收集了美、英、德、日等国从 1811 年到现在的光学镜头资料共 3000 多种，现挑选其中的一部分经补充整理之后，将其出版，以供我国从事光学镜头设计的人员参考。

原资料中，大多没有给出象差曲线图，我们均重新计算给予补上。由于原资料的光阑位置大多没有给出，我们计算时只能根据我们主观给定的光阑位置进行计算，因此相应的象差曲线图仅供参考。

本册的内容为变焦距物镜。其中 04-03-032 至 04-03-046 共 15 个镜头，由于面数太多，我们计算机的程序无法计算，所以没有给出象差曲线图。

由于我们水平有限，时间仓促，力量不足，所以只能一部分一部分地整理出版，而且在整理过程中一定会存在不少缺点和错误，分类也可能不完全合理，望读者批评指正。

参加本册编译工作的有林茂智、杨甦田、叶恩霖等。

编译者

# 目 录

|                      |    |
|----------------------|----|
| 符号说明                 | 1  |
| 四组变焦距物镜              | 2  |
| 变焦距物镜                | 5  |
| 变焦距摄影物镜              | 8  |
| 变焦距摄影物镜              | 12 |
| 具有可动正组的变焦距物镜         | 15 |
| 八片式变焦距物镜             | 18 |
| 变焦距镜头                | 21 |
| 八片式变焦距物镜             | 23 |
| 变焦距物镜                | 26 |
| 变焦距物镜                | 29 |
| 用于近距离摄影的变焦距镜头        | 32 |
| 变焦距镜头                | 35 |
| 变焦距物镜                | 38 |
| 变焦距镜头                | 41 |
| 变焦距镜头                | 43 |
| 大孔径变焦距物镜             | 45 |
| 两个可动负组在两个固定正组间的变焦距镜头 | 48 |
| 大孔径变焦距物镜             | 51 |
| 大孔径变焦距物镜             | 54 |
| 变焦距摄影物镜              | 57 |
| 变焦距镜头                | 60 |
| 变焦距镜头                | 63 |
| 变焦距镜头                | 66 |
| 变焦距镜头                | 69 |
| 变焦距摄影物镜              | 72 |
| 可动透镜作线性差动式移动的变焦距镜头   | 75 |
| 大孔径变焦距物镜             | 77 |
| 变焦距物镜                | 80 |
| 广角变焦距物镜              | 82 |
| 光学补偿式变焦距物镜           | 85 |
| 可动透镜作线性差动式移动的变焦距镜头   | 88 |

|                      |     |
|----------------------|-----|
| 大倍率变焦距镜头.....        | 90  |
| 小型的大倍率变焦距镜头.....     | 91  |
| 变焦距镜头.....           | 92  |
| 变焦距电影摄影镜头.....       | 93  |
| 变焦距镜头.....           | 94  |
| 大倍率大孔径变焦距物镜.....     | 95  |
| 大倍率变焦距镜头.....        | 96  |
| 用于中心快门照相机的变焦距镜头..... | 97  |
| 小型的变焦距镜头.....        | 98  |
| 具有两个光栏的变焦距镜头.....    | 99  |
| 超远摄型变焦距镜头.....       | 100 |
| 大孔径广角变焦距镜头.....      | 101 |
| 大孔径变焦距物镜.....        | 102 |
| 大倍率变焦距镜头.....        | 103 |
| 五组变焦距镜头.....         | 104 |

## 符号说明

1. 凡数据后有符号“\*”，表示光栏位置或其值间有光栏。

凡数据后有符号“\*\*”，表示原资料中未给出F.A.值，此系我们在计算时主观给定的值。

2. 在主要参数表中，当d值是可变的，则用符号“\*\*\*”表示。

3. 凡没有注明数值单位的，均以毫米为单位；若注明以英寸为单位，则在该镜头资料中均以英寸为单位。

4. 常用符号：

|               |               |
|---------------|---------------|
| $\Sigma S_1$  | 球差系数和；        |
| $\Sigma S_2$  | 彗差系数和；        |
| $\Sigma S_3$  | 象散系数和；        |
| $\Sigma S_4$  | 场曲系数和；        |
| $\Sigma S_5$  | 畸变系数和；        |
| $LA'$         | 球差；           |
| $\Delta H'$   | 绝对畸变；         |
| $x'_i$        | 细光束子午场曲；      |
| $x'_s$        | 细光束弧矢场曲；      |
| $x'_i - x'_s$ | 象散；           |
| $K'_{T1}$     | 全口径的子午彗差；     |
| $K'_{T0.7}$   | 0.707口径的子午彗差； |
| QP            | 相对畸变；         |
| HI            | 理想象高；         |
| E. F. L       | 焦距；           |
| B. F. L       | 后截距；          |
| FNo.          | 相对孔径倒数；       |
| F. A.         | 视场角；          |
| $\eta$        | 物高；           |
| $\omega$      | 镜头视场。         |

编号: 04-03-001

## 四组变焦距物镜

E.F.L=0.641~1.560 B.F.L=0.520 FNo.=9 F.A.=±26.9°~±10.9°

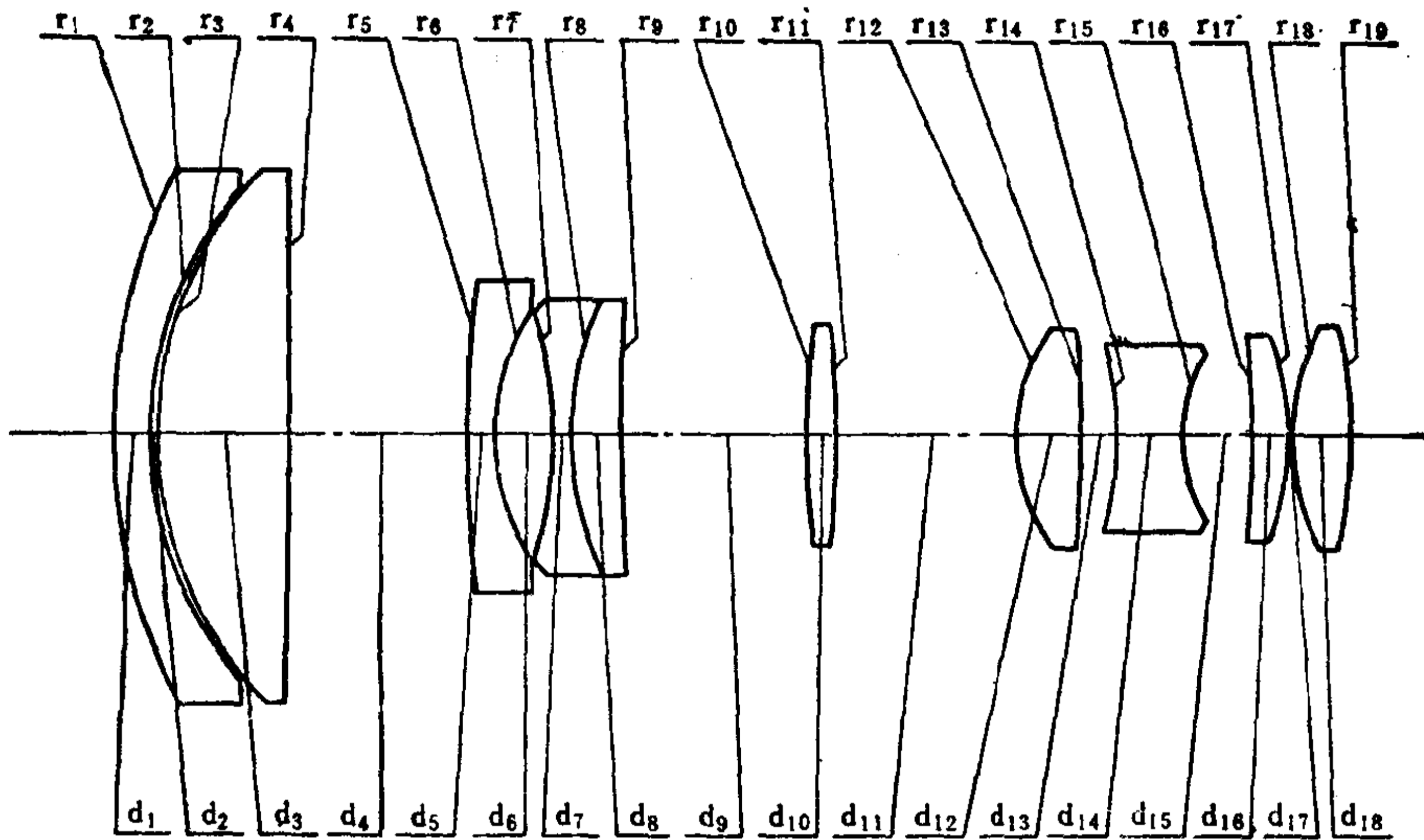

| 序号 | r        | d     | na      | va    | 序号 | r        | d      | na      | va    |
|----|----------|-------|---------|-------|----|----------|--------|---------|-------|
| 1  | 1.6604   | 0.100 | 1.78470 | 26.08 | 11 | -2.9979  | 0.505* |         |       |
| 2  | 1.0347   | 0.009 |         |       | 12 | 0.5052   | 0.177  | 1.71300 | 53.83 |
| 3  | 1.0682   | 0.364 | 1.71300 | 53.83 | 13 | -5.8668  | 0.102  |         |       |
| 4  | -55.1950 | *** 1 |         |       | 14 | -0.9660  | 0.186  | 1.78470 | 26.08 |
| 5  | 12.9360  | 0.070 | 1.58144 | 40.85 | 15 | 0.4479   | 0.193  |         |       |
| 6  | 0.6295   | 0.155 |         |       | 16 | -2.7248  | 0.102  | 1.71300 | 53.83 |
| 7  | -1.1272  | 0.061 | 1.51821 | 65.05 | 17 | -0.7910  | 0.006  |         |       |
| 8  | 0.8742   | 0.130 | 1.78470 | 26.08 | 18 | 0.6437   | 0.162  | 1.71300 | 53.83 |
| 9  | 6.0136   | *** 2 |         |       | 19 | -13.8970 |        |         |       |
| 10 | 2.9979   | 0.081 | 1.62014 | 63.52 |    |          |        |         |       |

0.505\* = 0.300 + 0.205

04-03-001-1

|                | $\Sigma S_1$ | $\Sigma S_2$ | $\Sigma S_3$ | $\Sigma S_4$ | $\Sigma S_5$ | HI         | QP(1 $\omega$ ) |
|----------------|--------------|--------------|--------------|--------------|--------------|------------|-----------------|
|                | - 0.0000028  | - 0.0000106  | 0.0000228    | - 0.0000455  | - 0.0019261  | 0.325      | - 13%           |
| h 或 $\omega$ % | LA'          | $\Delta H'$  | $x_t$        | $x_s$        | $x_t - x_s$  | $K'_{T1}$  | $K'_{T0.7}$     |
| 100            | - 0.00046    | - 0.0442     | - 0.0770     | - 0.0050     | - 0.0720     | - 0.002060 | - 0.000990      |
| 70             | - 0.00024    | - 0.0088     | - 0.0020     | 0.0003       | - 0.0023     | - 0.000091 | - 0.000046      |

E. F. L = 0.641 ( $\pm 26.9^\circ$ )

\*\*\*1 = 0.035, \*\*\*2 = 0.816

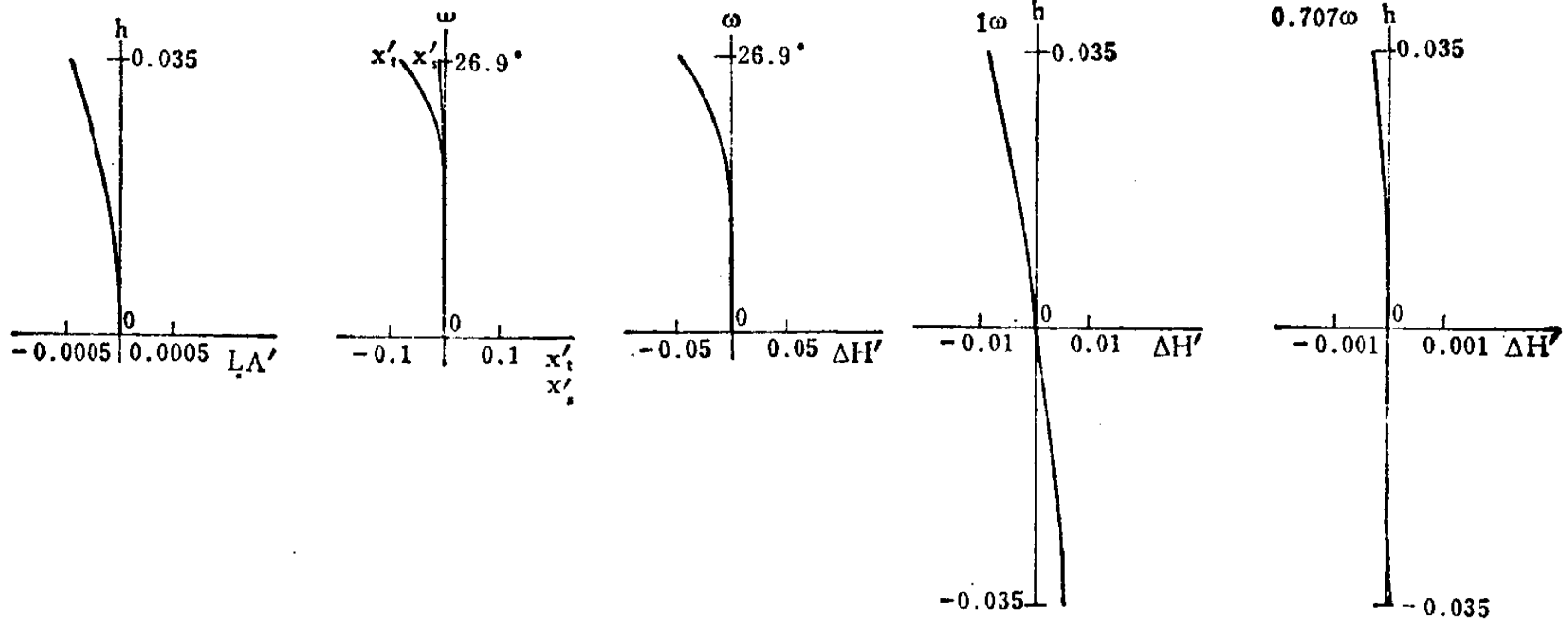

04-03-001-2

|                | $\Sigma S_1$ | $\Sigma S_2$ | $\Sigma S_3$ | $\Sigma S_4$ | $\Sigma S_5$ | HI         | QP(1 $\omega$ ) |
|----------------|--------------|--------------|--------------|--------------|--------------|------------|-----------------|
|                | - 0.0000026  | - 0.0000022  | 0.0000383    | - 0.0000479  | 0.0003027    | 0.309      | - 9%            |
| h 或 $\omega$ % | LA'          | $\Delta H'$  | $x_t$        | $x_s$        | $x_t - x_s$  | $K'_{T1}$  | $K'_{T0.7}$     |
| 100            | - 0.00042    | - 0.0280     | - 0.0951     | - 0.00430    | - 0.0908     | - 0.009090 | - 0.004130      |
| 70             | - 0.00022    | 0.0001       | 0.0004       | 0.00005      | - 0.0001     | - 0.000134 | - 0.000067      |

E. F. L = 1.000 ( $\pm 17.2^\circ$ )

\*\*\*1 = 0.501, \*\*\*2 = 0.516

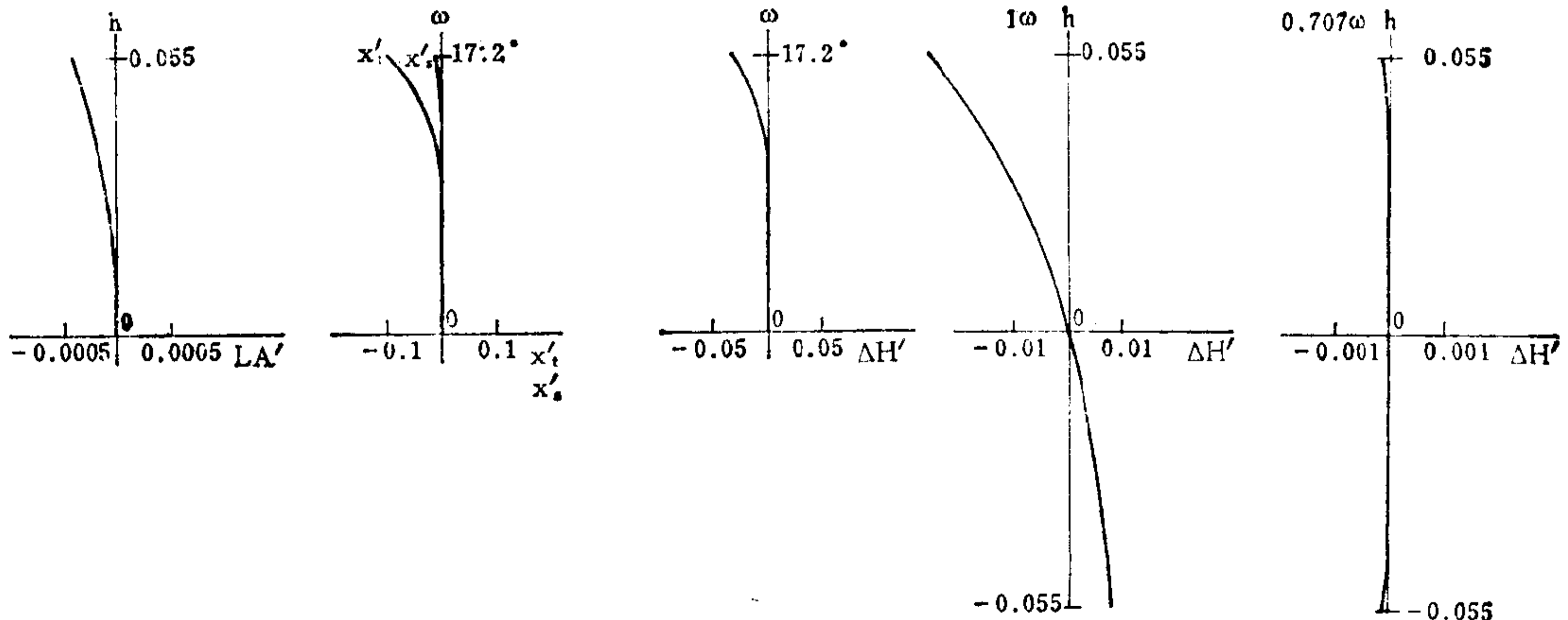

04-03-001-3

|                | $\Sigma S_1$ | $\Sigma S_2$ | $\Sigma S_3$ | $\Sigma S_4$ | $\Sigma S_5$  | HI         | QP(1 $\omega$ ) |
|----------------|--------------|--------------|--------------|--------------|---------------|------------|-----------------|
|                | - 0.0000027  | 0.0000056    | - 0.0000142  | - 0.0000478  | 0.0014143     | 0.300      | - 6 %           |
| h 或 $\omega$ % | LA'          | $\Delta H'$  | $x'_t$       | $x'_s$       | $x'_t - x'_s$ | $K'_{T1}$  | $K'_{T0.7}$     |
| 100            | - 0.00043    | - 0.0184     | - 0.0854     | - 0.0026     | - 0.0828      | - 0.008800 | - 0.004020      |
| 70             | - 0.00022    | 0.0031       | - 0.0010     | - 0.0009     | - 0.0001      | - 0.000163 | - 0.000078      |

E. F. L = 1.560 ( $\pm 10.9^\circ$ )

\*\*\*1 = 0.800, \*\*\*2 = 0.049

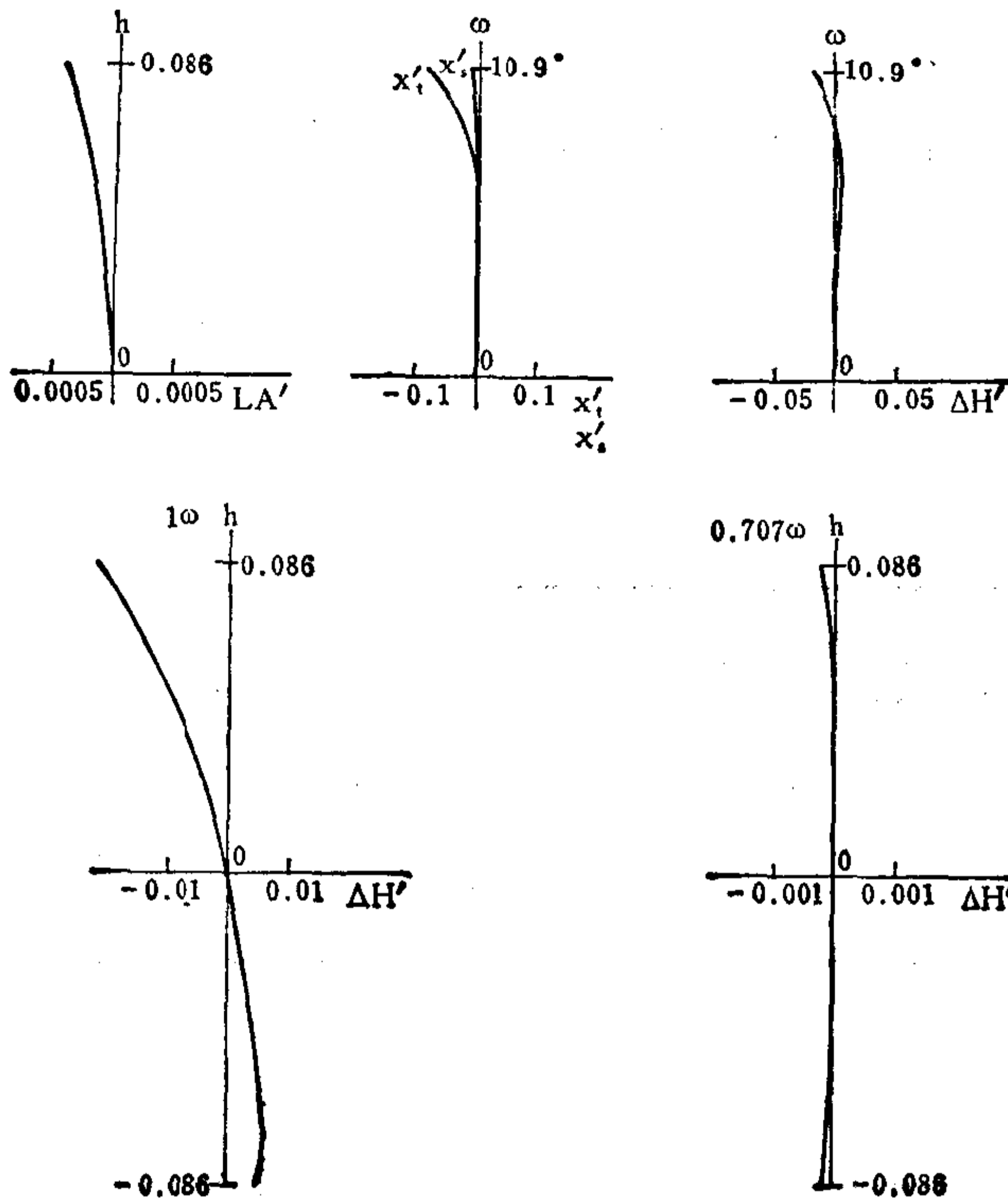



编号: 04-03-002

## 变 焦 距 物 镜

E.F.L=9.3~35.4 B.F.L=15.25 FNo.=1.9 F.A.=±21.6°~±5.6°

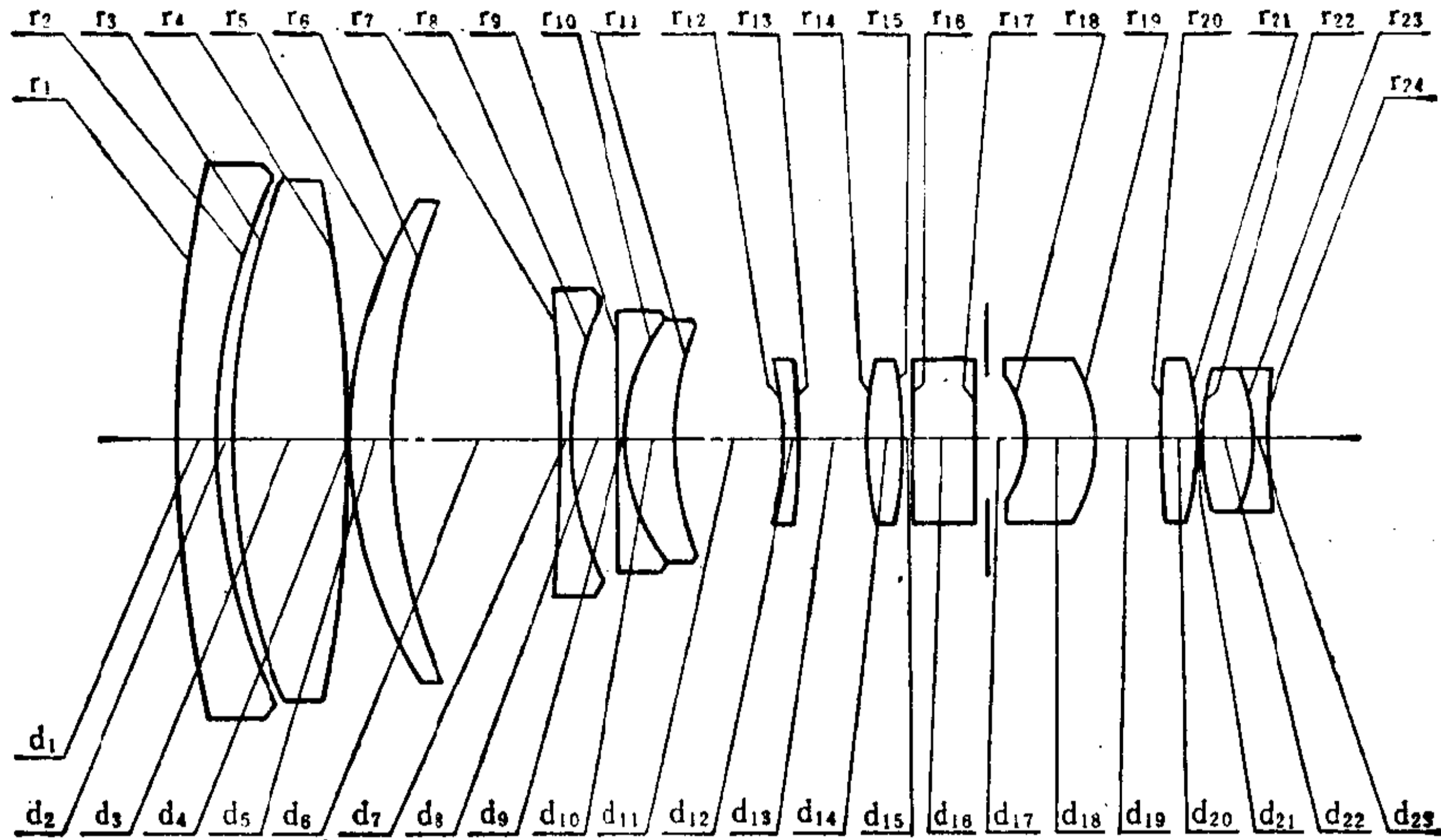

| 序号 | r         | d     | $n_e$   | $v_e$ | 序号 | r         | d     | $n_e$   | $v_e$ |
|----|-----------|-------|---------|-------|----|-----------|-------|---------|-------|
| 1  | 112.2000  | 3.00  | 1.79180 | 25.90 | 13 | - 51.5820 | *** 3 |         |       |
| 2  | 46.9960   | 1.20  |         |       | 14 | 28.7990   | 2.50  | 1.69400 | 54.60 |
| 3  | 50.1190   | 8.70  | 1.62287 | 60.06 | 15 | - 35.9950 | 0.70  |         |       |
| 4  | -110.6000 | 0.05  |         |       | 16 | $\infty$  | 5.00  | 1.57832 | 41.04 |
| 5  | 33.9820   | 3.50  | 1.62287 | 60.06 | 17 | $\infty$  | 4.00* |         |       |
| 6  | 47.6570   | *** 1 |         |       | 18 | - 8.2937  | 5.30  | 1.74618 | 27.97 |
| 7  | -139.2400 | 1.00  | 1.69400 | 54.60 | 19 | - 11.9710 | 5.10  |         |       |
| 8  | 24.5820   | 3.50  |         |       | 20 | 87.8520   | 2.80  | 1.69400 | 54.60 |
| 9  | 930.5700  | 0.80  | 1.52010 | 65.01 | 21 | - 24.0570 | 0.05  |         |       |
| 10 | 14.8550   | 3.50  | 1.79180 | 25.90 | 22 | 20.9830   | 4.00  | 1.69660 | 53.18 |
| 11 | 24.4060   | *** 2 |         |       | 23 | - 14.1250 | 1.00  | 1.81262 | 25.28 |
| 12 | - 22.8760 | 1.30  | 1.66151 | 50.69 | 24 | 45.9730   |       |         |       |

4.00\* = 1.50 + 2.50



04-03-002-1

|                | $\Sigma S_1$ | $\Sigma S_2$ | $\Sigma S_3$ | $\Sigma S_4$ | $\Sigma S_5$  | HI        | QP(1 $\omega$ ) |
|----------------|--------------|--------------|--------------|--------------|---------------|-----------|-----------------|
|                | - 0.02495    | - 0.00163    | 0.00217      | - 0.00578    | - 0.06571     | 3.7       | - 3.1%          |
| h 或 $\omega$ % | LA'          | $\Delta H'$  | $x'_i$       | $x'_s$       | $x'_i - x'_s$ | $K_{T1}$  | $K'_{T0.7}$     |
| 100            | 0.0357       | - 0.1147     | - 0.0864     | - 0.0406     | - 0.0458      | - 0.00453 | - 0.00007       |
| 70             | - 0.0476     | - 0.0452     | - 0.0214     | - 0.0186     | - 0.0028      | - 0.02476 | - 0.00814       |

E. F. L = 9.3 ( $\pm 21.6^\circ$ )

\*\*\* 1 = 2.500, \*\*\* 2 = 30.971, \*\*\* 3 = 1.724

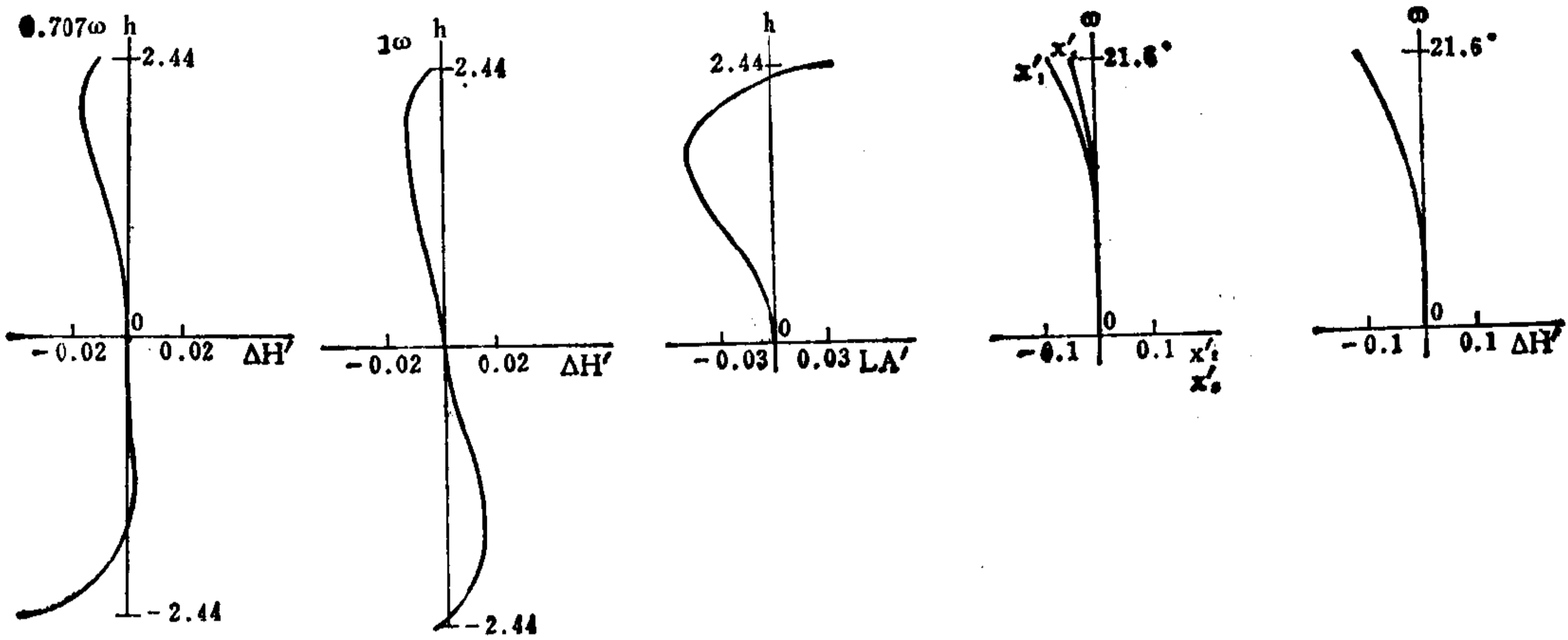

04-03-002-2

|                | $\Sigma S_1$ | $\Sigma S_2$ | $\Sigma S_3$ | $\Sigma S_4$ | $\Sigma S_5$  | HI        | QP(1 $\omega$ ) |
|----------------|--------------|--------------|--------------|--------------|---------------|-----------|-----------------|
|                | - 0.02145    | 0.00742      | - 0.00224    | - 0.00602    | 0.01174       | 3.5       | 1.6%            |
| h 或 $\omega$ % | LA'          | $\Delta H'$  | $x'_i$       | $x'_s$       | $x'_i - x'_s$ | $K_{T1}$  | $K'_{T0.7}$     |
| 100            | 0.0633       | 0.0572       | - 0.1135     | - 0.0471     | - 0.0664      | 0.01790   | 0.01118         |
| 70             | - 0.0335     | 0.0120       | - 0.0321     | - 0.0219     | - 0.0102      | - 0.00240 | 0.00314         |

E. F. L = 20.2 ( $\pm 9.9^\circ$ )

\*\*\* 1 = 21.650, \*\*\* 2 = 8.223, \*\*\* 3 = 5.322

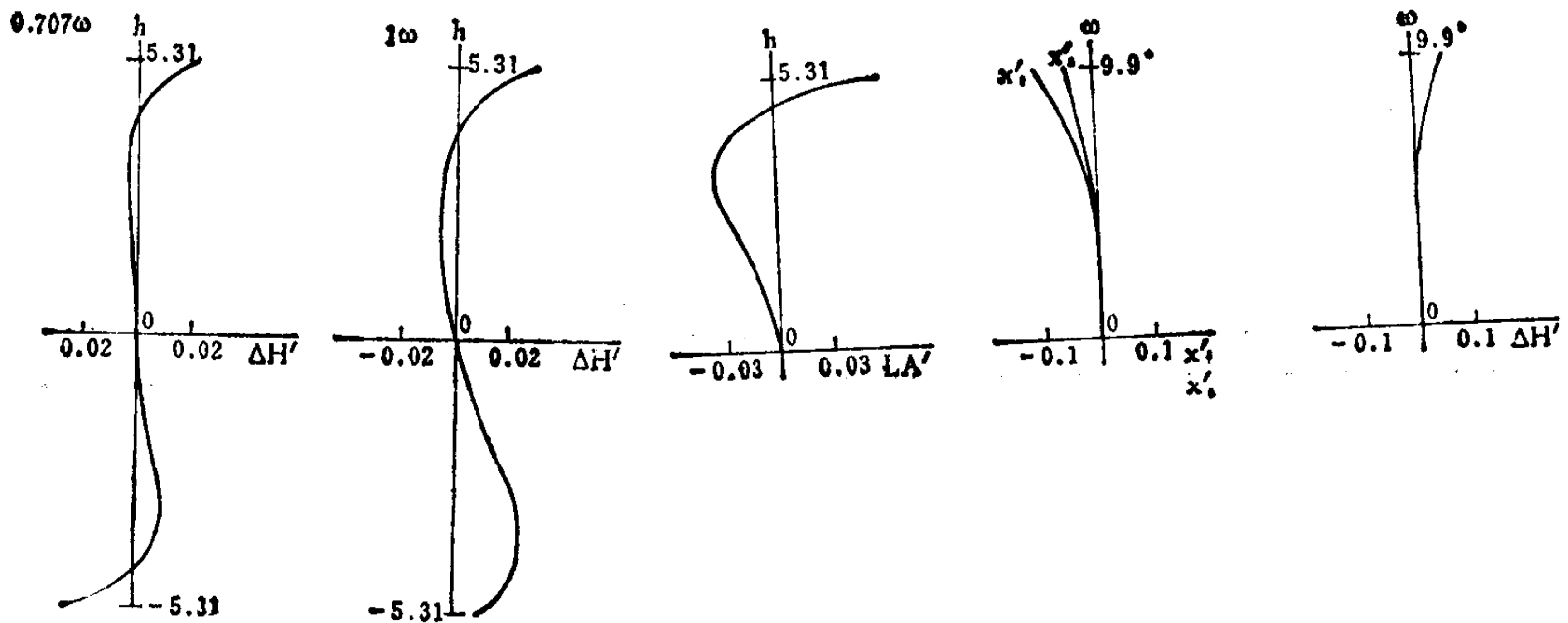

04-03-002-3

|                | $\Sigma S_1$ | $\Sigma S_2$ | $\Sigma S_3$ | $\Sigma S_4$ | $\Sigma S_5$  | HI        | QP(1 $\omega$ ) |
|----------------|--------------|--------------|--------------|--------------|---------------|-----------|-----------------|
|                | - 0.02189    | 0.01183      | - 0.00273    | - 0.00608    | 0.02969       | 3.5       | 1.9%            |
| h 或 $\omega$ % | LA'          | $\Delta H'$  | $x'_i$       | $x'_s$       | $x'_i - x'_s$ | $K'_{T1}$ | $K'_{T0.7}$     |
| 100            | 0.0551       | 0.0694       | - 0.0491     | - 0.0410     | - 0.0081      | 0.010800  | 0.014060        |
| 70             | - 0.0357     | 0.0217       | - 0.0277     | - 0.0228     | - 0.0049      | 0.012270  | 0.012808        |

E. F. L = 35.4 ( $\pm 5.6^\circ$ )

\*\*\*1 = 31.500, \*\*\*2 = 1.910, \*\*\*3 = 1.785

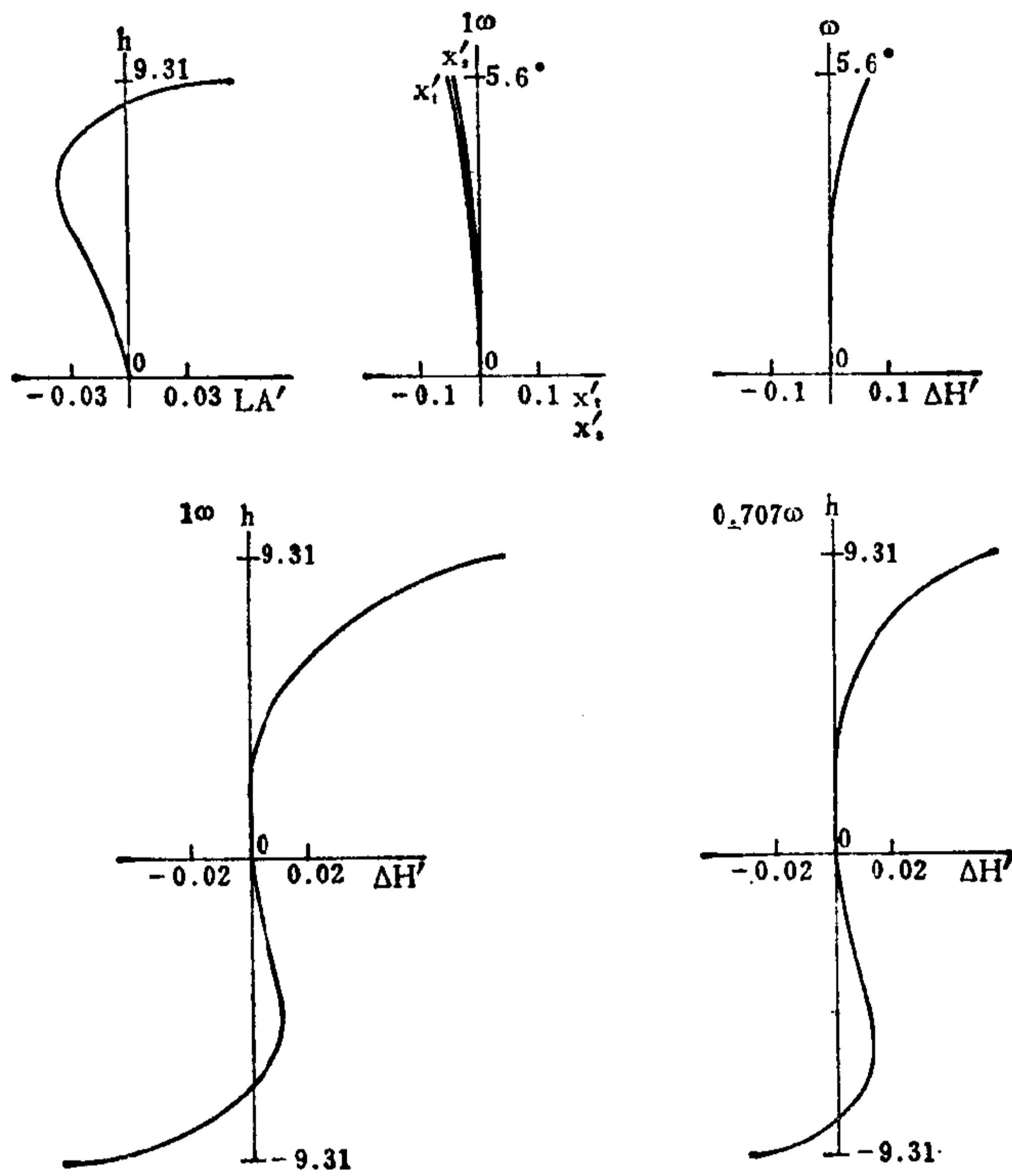

编号: 04-03-003

## 变 焦 距 摄 影 物 镜

E. F. L = 12.34 ~ 29.08    B. F. L = 9.58    FNo. = 1.9    F. A. = ± 16° ~ ± 6.9°

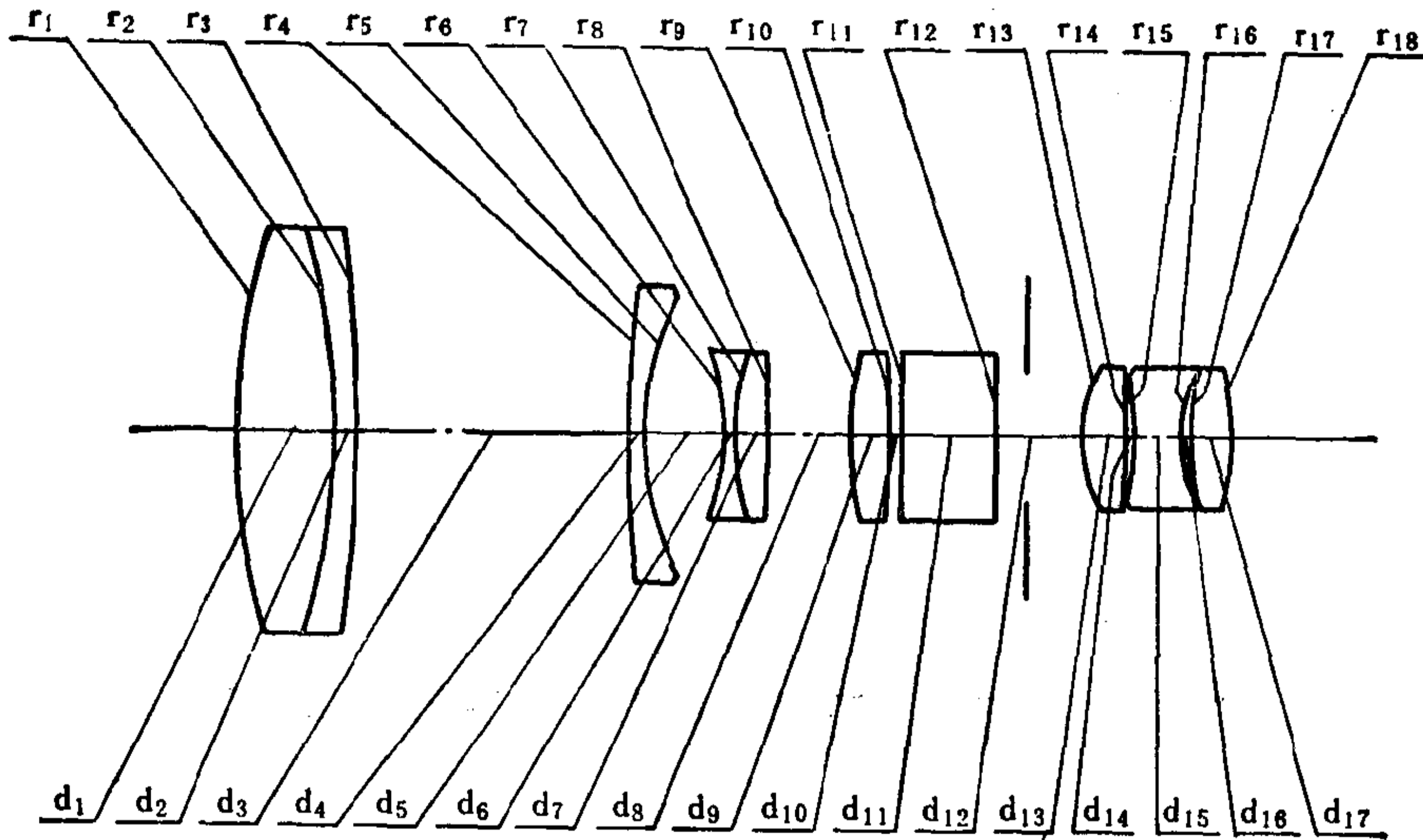

| 序号 | r         | d     | na      | va    | 序号 | r         | d    | na      | va    |
|----|-----------|-------|---------|-------|----|-----------|------|---------|-------|
| 1  | 48.3490   | 6.0   | 1.62299 | 58.06 | 10 | - 64.9380 | 0.7  |         |       |
| 2  | - 41.8680 | 1.2   | 1.78470 | 26.08 | 11 | ∞         | 6.0  | 1.51680 | 64.17 |
| 3  | -149.6300 | *** 1 |         |       | 12 | ∞         | 5.2* |         |       |
| 4  | 127.7210  | 1.0   | 1.62041 | 60.33 | 13 | 8.9123    | 2.7  | 1.71300 | 53.83 |
| 5  | 18.1710   | *** 2 |         |       | 14 | - 95.0290 | 0.4  |         |       |
| 6  | - 14.8530 | 0.8   | 1.51742 | 52.20 | 15 | - 20.2410 | 3.2  | 1.78470 | 26.08 |
| 7  | 18.1710   | 2.0   | 1.71736 | 29.51 | 16 | 8.5340    | 0.6  |         |       |
| 8  | -262.2700 | *** 3 |         |       | 17 | 18.1710   | 2.4  | 1.74400 | 44.77 |
| 9  | 20.9820   | 2.3   | 1.62041 | 60.33 | 18 | - 18.1710 |      |         |       |

5.2\* = 2.0 + 3.2

04-03-003-1

|                | $\Sigma S_1$ | $\Sigma S_2$ | $\Sigma S_3$ | $\Sigma S_4$ | $\Sigma S_5$  | HI        | QP(1 $\omega$ ) |
|----------------|--------------|--------------|--------------|--------------|---------------|-----------|-----------------|
|                | - 0.03939    | - 0.00435    | 0.00122      | - 0.01877    | - 0.03310     | 3.5       | - 1.9%          |
| h 或 $\omega$ % | LA'          | $\Delta H'$  | $x'_t$       | $x'_s$       | $x'_t - x'_s$ | $K'_{T1}$ | $K'_{T0.7}$     |
| 100            | 0.0456       | - 0.0701     | - 0.0235     | - 0.1022     | 0.0787        | 0.13752   | 0.01633         |
| 70             | - 0.0757     | - 0.0240     | - 0.0386     | - 0.0591     | 0.0205        | 0.07779   | 0.00839         |

E. F. L = 12.34 ( $\pm 16^\circ$ )

\*\*\*1 = 1.70, \*\*\*2 = 18.14, \*\*\*3 = 8.36

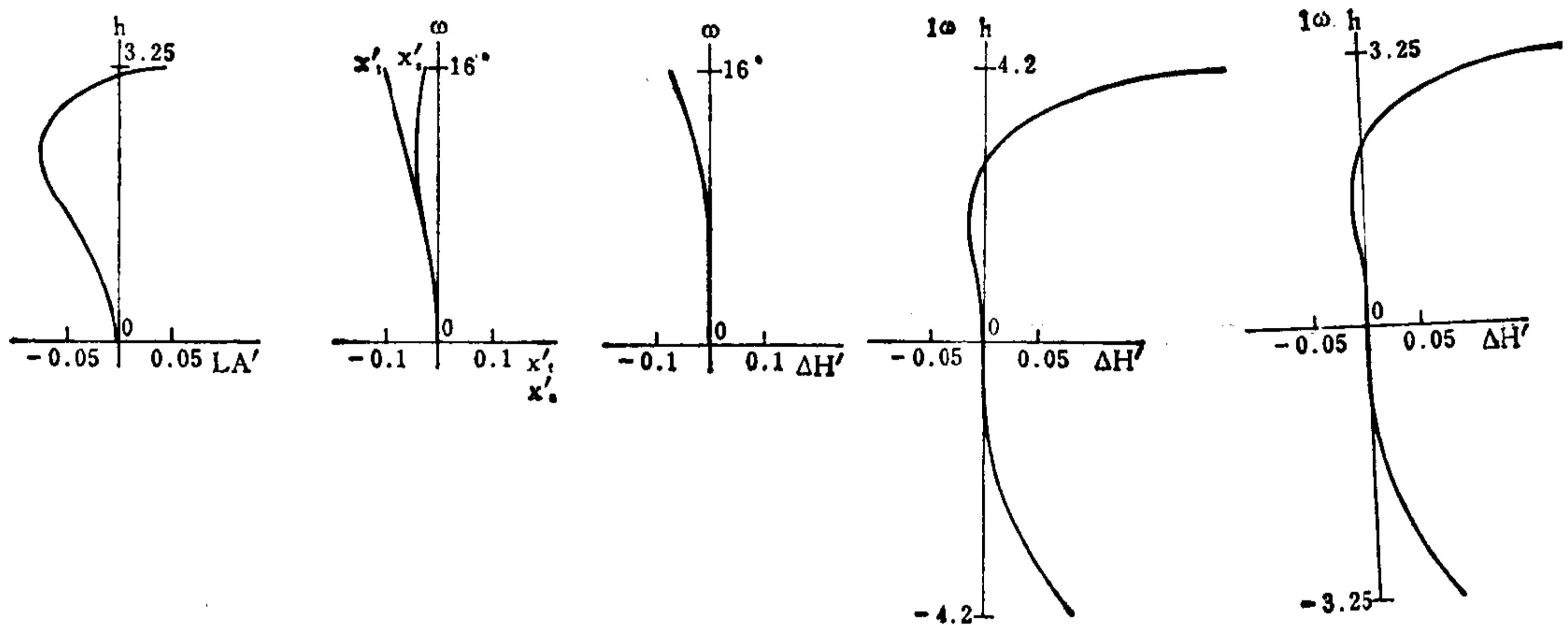

04-03-003-2

|                | $\Sigma S_1$ | $\Sigma S_2$ | $\Sigma S_3$ | $\Sigma S_4$ | $\Sigma S_5$  | HI       | QP(1 $\omega$ ) |
|----------------|--------------|--------------|--------------|--------------|---------------|----------|-----------------|
|                | - 0.03631    | - 0.00249    | - 0.00197    | - 0.01955    | - 0.01093     | 3.6      | - 0.8%          |
| h 或 $\omega$ % | LA'          | $\Delta H'$  | $x'_t$       | $x'_s$       | $x'_t - x'_s$ | $K_{T1}$ | $K'_{T0.7}$     |
| 100            | 0.0542       | - 0.0309     | - 0.0441     | - 0.1210     | 0.0769        | 0.15447  | 0.01834         |
| 70             | - 0.0679     | - 0.0094     | - 0.0648     | - 0.0715     | 0.0067        | 0.08555  | 0.01068         |

E. F. L = 16.03 ( $\pm 12.6^\circ$ )

\*\*\*1 = 9.75, \*\*\*2 = 10.86, \*\*\*3 = 7.59

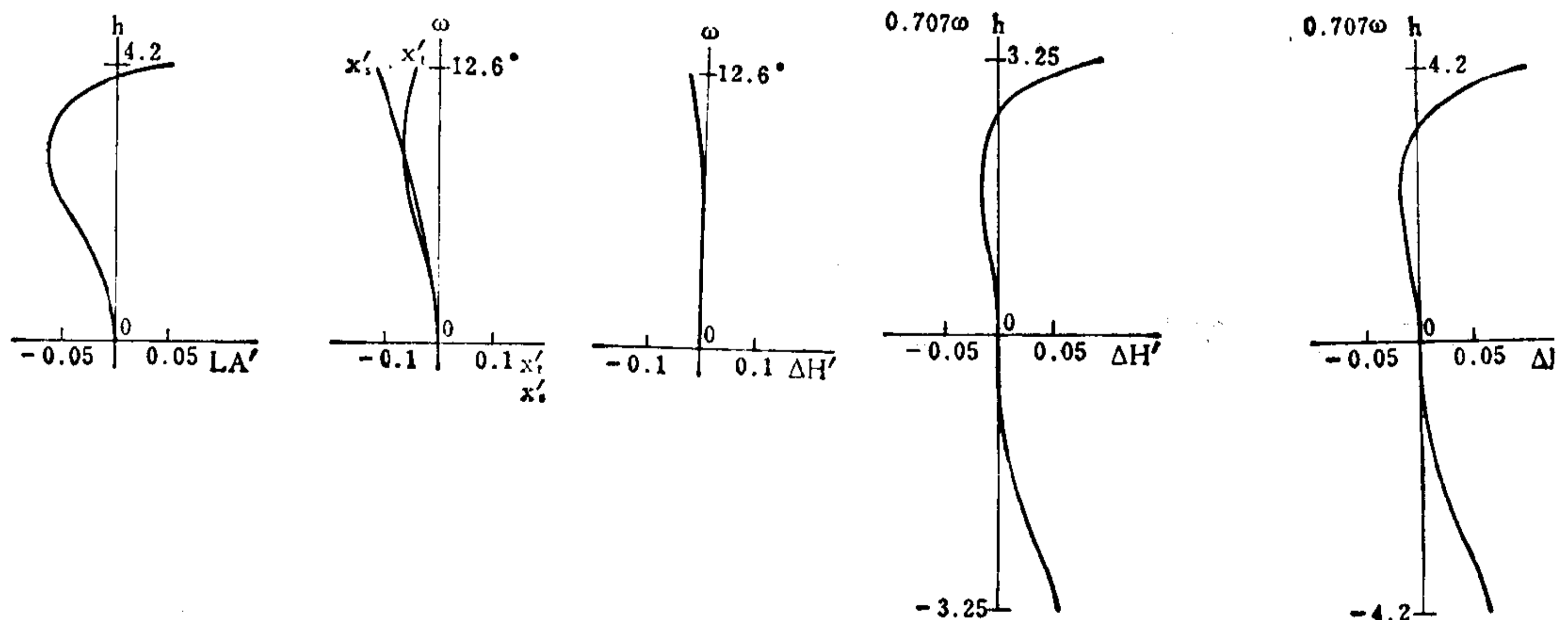

04-03-003-3

|                | $\Sigma S_1$ | $\Sigma S_2$ | $\Sigma S_3$ | $\Sigma S_4$ | $\Sigma S_5$  | HI        | QP(1 $\omega$ ) |
|----------------|--------------|--------------|--------------|--------------|---------------|-----------|-----------------|
|                | - 0.03636    | - 0.00225    | - 0.00152    | - 0.01966    | 0.00411       | 3.5       | - 0.04%         |
| h 或 $\omega$ % | LA'          | $\Delta H'$  | $x'_t$       | $x'_s$       | $x'_t - x'_s$ | $K'_{T1}$ | $K'_{T0.7}$     |
| 100            | 0.0664       | - 0.0014     | 0.0121       | - 0.1079     | 0.1200        | 0.14640   | 0.01087         |
| 70             | - 0.0646     | 0.0011       | - 0.0474     | - 0.0664     | 0.0190        | 0.08663   | 0.00973         |

E. F. L = 21.55 ( $\pm 9.3^\circ$ )

\*\*\*1 = 17.80; \*\*\*2 = 5.10; \*\*\*3 = 5.30

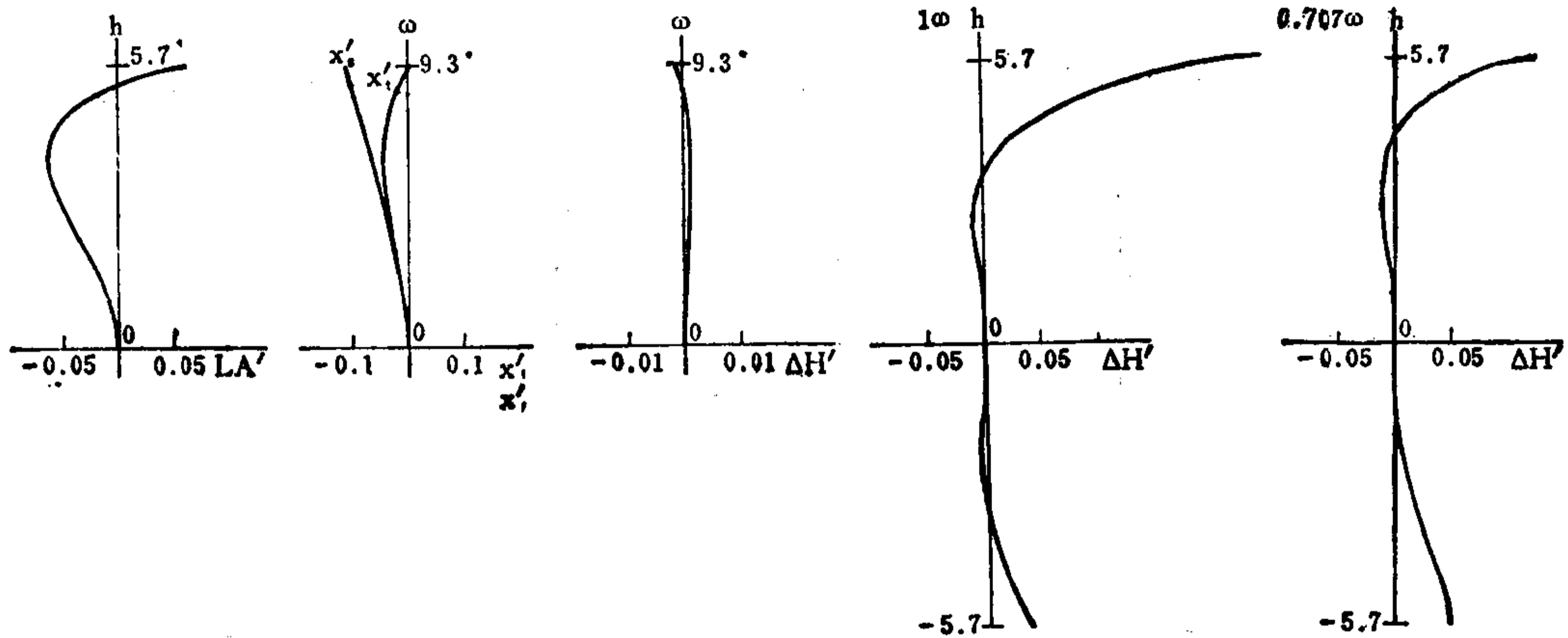

04-03-003-4

|                | $\Sigma S_1$ | $\Sigma S_2$ | $\Sigma S_3$ | $\Sigma S_4$ | $\Sigma S_5$  | HI        | QP(1 $\omega$ ) |
|----------------|--------------|--------------|--------------|--------------|---------------|-----------|-----------------|
|                | - 0.036170   | - 0.003650   | 0.000002     | - 0.019600   | 0.014525      | 3.5       | 0.57%           |
| h 或 $\omega$ % | LA'          | $\Delta H'$  | $x'_t$       | $x'_s$       | $x'_t - x'_s$ | $K'_{T1}$ | $K'_{T0.7}$     |
| 100            | 0.0465       | 0.0204       | 0.0687       | - 0.0955     | 0.1642        | 0.09755   | - 0.00697       |
| 70             | - 0.0693     | 0.0086       | - 0.0267     | - 0.0610     | 0.0343        | 0.06740   | 0.00266         |

E. F. L = 26.14 ( $\pm 7.7^\circ$ )

\*\*\*1 = 22.40; \*\*\*2 = 3.03; \*\*\*3 = 2.77

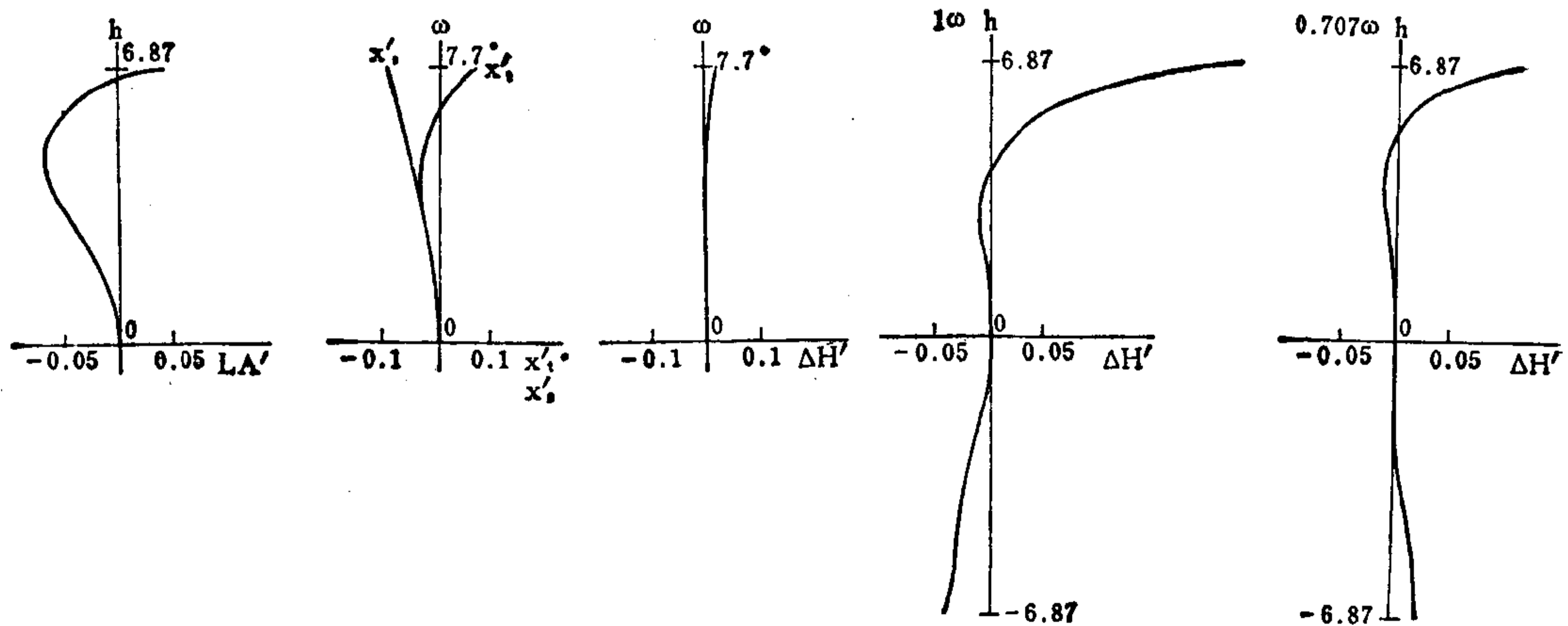

04-03-003-5

|                | $\Sigma S_1$ | $\Sigma S_2$ | $\Sigma S_3$ | $\Sigma S_4$ | $\Sigma S_5$  | HI       | QP(1 $\omega$ ) |
|----------------|--------------|--------------|--------------|--------------|---------------|----------|-----------------|
|                | - 0.03737    | - 0.00538    | 0.00041      | - 0.01951    | 0.02101       | 3.5      | 0.98%           |
| h 或 $\omega$ % | LA'          | $\Delta H'$  | $x'_1$       | $x'_2$       | $x'_1 - x'_2$ | $K_{T1}$ | $K_{T0.7}$      |
| 100            | 0.0335       | 0.0345       | 0.0819       | - 0.0929     | 0.1748        | 0.05797  | - 0.02156       |
| 70             | - 0.0747     | 0.0132       | - 0.0218     | - 0.0595     | 0.0377        | 0.05096  | - 0.00385       |

E. F. L = 29.08 ( $\pm 6.9^\circ$ )

\*\*\*1 = 24.70; \*\*\*2 = 2.50; \*\*\*3 = 1.00

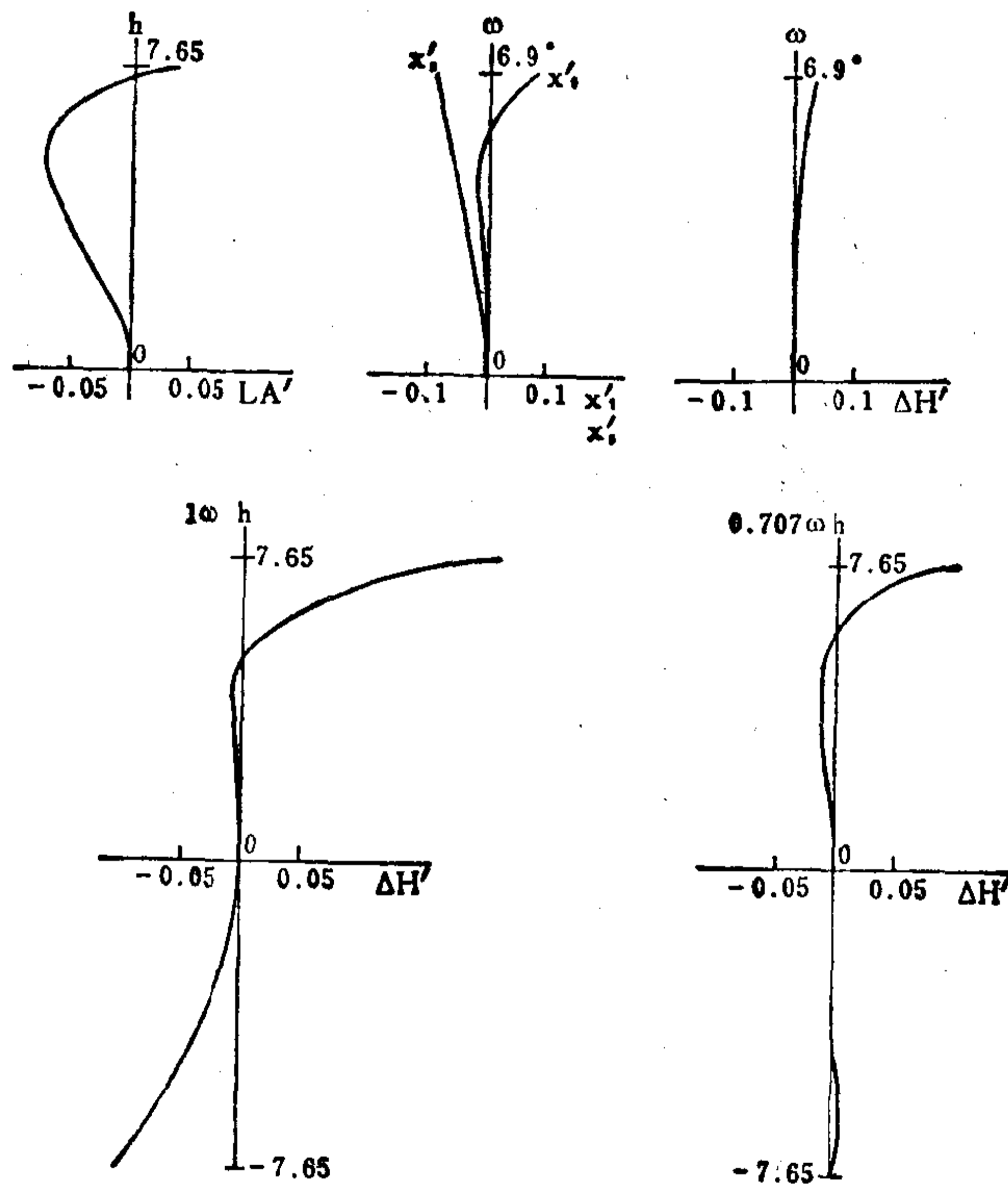

编号: 04-03-004

## 变 焦 距 摄 影 物 镜

E.F.L = 10.25 ~ 34.30 B.F.L = 13.28 FNo. = 1.6 F.A. =  $\pm 19.5^\circ \sim \pm 5.7^\circ$

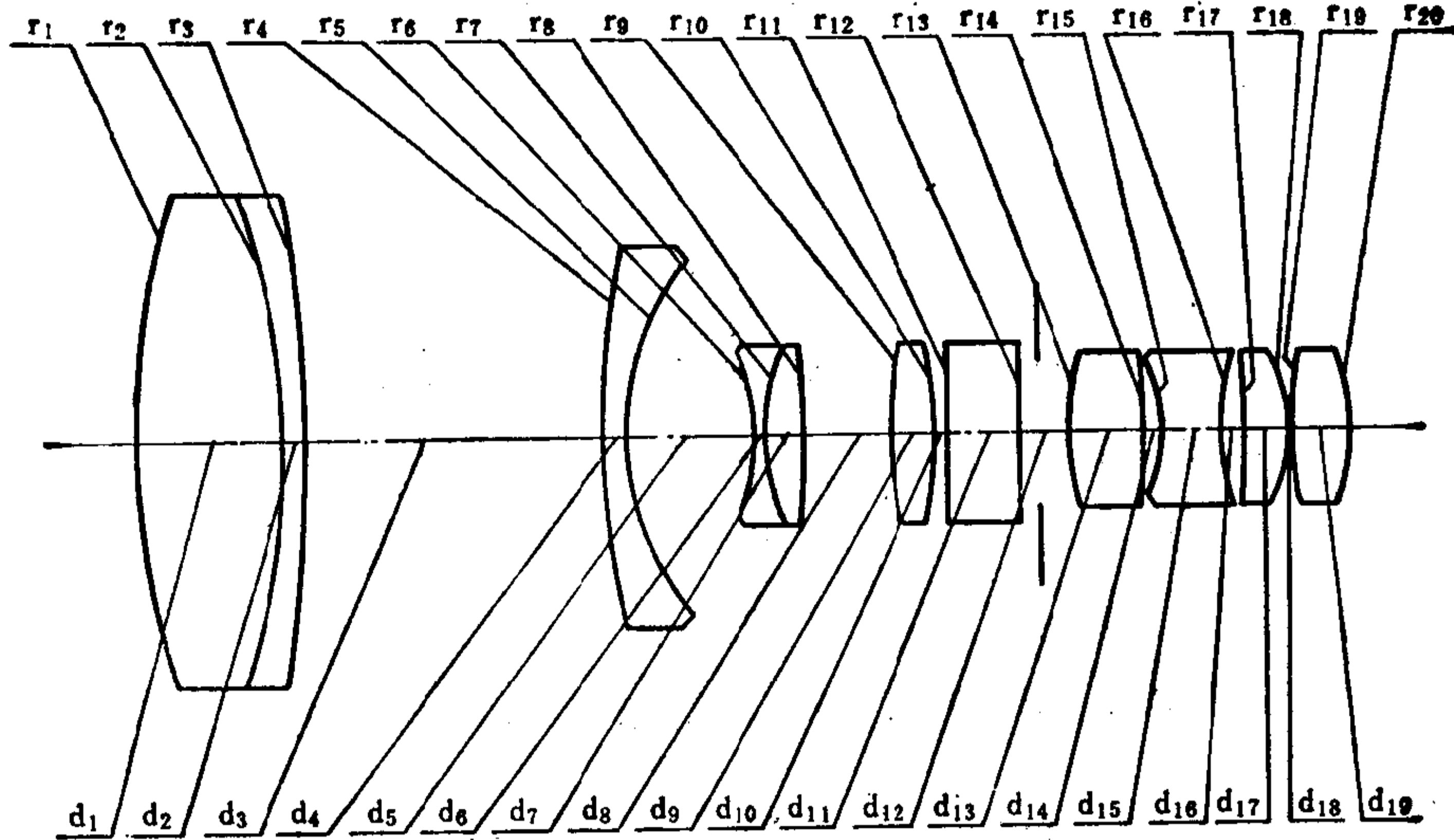

| 序号 | r        | d     | nd      | vd    | 序号 | r        | d    | nd      | vd    |
|----|----------|-------|---------|-------|----|----------|------|---------|-------|
| 1  | 54.640   | 10.0  | 1.62280 | 56.90 | 11 | $\infty$ | 5.0  | 1.51680 | 64.17 |
| 2  | -47.655  | 1.6   | 1.78470 | 26.08 | 12 | $\infty$ | 3.3* |         |       |
| 3  | -170.342 | *** 1 |         |       | 13 | 18.564   | 5.0  | 1.62041 | 60.33 |
| 4  | 76.625   | 1.2   | 1.71300 | 53.83 | 14 | -62.194  | 1.5  |         |       |
| 5  | 19.112   | *** 2 |         |       | 15 | -10.517  | 4.0  | 1.80518 | 25.43 |
| 6  | -15.849  | 1.0   | 1.71300 | 53.83 | 16 | 16.669   | 1.5  |         |       |
| 7  | 14.642   | 2.5   | 1.78470 | 26.08 | 17 | -365.150 | 3.0  | 1.62041 | 60.33 |
| 8  | -71.274  | *** 3 |         |       | 18 | -12.959  | 0.1  |         |       |
| 9  | 33.254   | 3.0   | 1.62041 | 60.33 | 19 | 24.758   | 4.0  | 1.62041 | 60.33 |
| 10 | -26.606  | 0.8   |         |       | 20 | -15.178  |      |         |       |

3.3\* = 1.3 + 2.0



04-03-004-1

|                | $\Sigma S_1$ | $\Sigma S_2$ | $\Sigma S_3$ | $\Sigma S_4$ | $\Sigma S_5$ | HI        | QP(1 $\omega$ ) |
|----------------|--------------|--------------|--------------|--------------|--------------|-----------|-----------------|
|                | - 0.06064    | - 0.00577    | 0.01256      | - 0.02995    | - 0.05659    | 3.6       | - 2.7%          |
| h 或 $\omega$ % | LA'          | $\Delta H'$  | $x'_i$       | $x_s$        | $x'_i - x_s$ | $K'_{T1}$ | $K_{T0.7}$      |
| 100            | 0.0142       | - 0.0995     | - 0.0116     | - 0.1079     | 0.0963       | 0.11140   | 0.02165         |
| 70             | - 0.0916     | - 0.0340     | - 0.0191     | - 0.0586     | 0.0395       | 0.12688   | 0.00952         |

E. F. L = 10.25 ( $\pm 19.5^\circ$ )

\*\*\*1 = 0.800; \*\*\*2 = 29.906; \*\*\*3 = 8.524

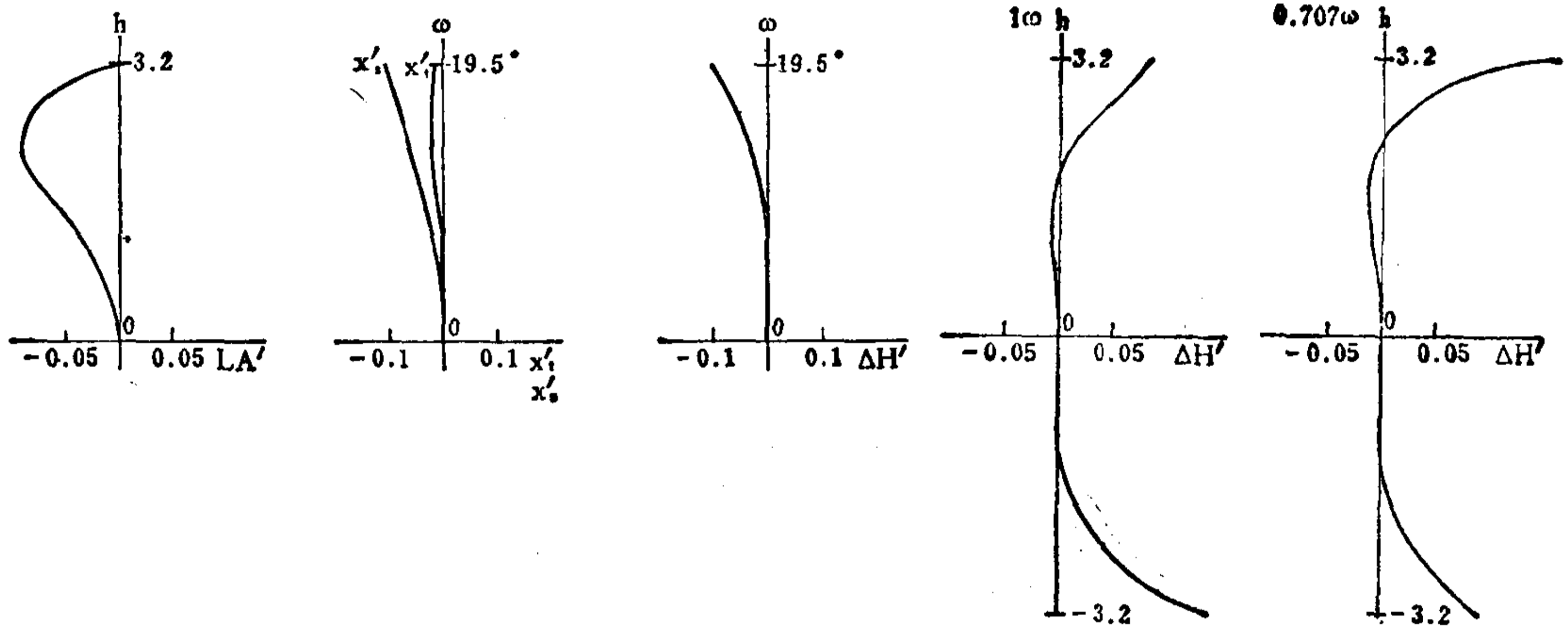

04-03-004-2

|                | $\Sigma S_1$ | $\Sigma S_2$ | $\Sigma S_3$ | $\Sigma S_4$ | $\Sigma S_5$ | HI        | QP(1 $\omega$ ) |
|----------------|--------------|--------------|--------------|--------------|--------------|-----------|-----------------|
|                | - 0.05362    | - 0.00975    | - 0.00728    | - 0.03138    | 0.00639      | 3.5       | - 0.79%         |
| h 或 $\omega$ % | LA'          | $\Delta H'$  | $x'_i$       | $x_s$        | $x'_i - x_s$ | $K'_{T1}$ | $K_{T0.7}$      |
| 100            | 0.0408       | - 0.0281     | - 0.0402     | - 0.1556     | 0.1153       | - 0.42407 | 0.02103         |
| 70             | - 0.0751     | - 0.0029     | - 0.0981     | - 0.0931     | - 0.0050     | 0.17227   | 0.01658         |

E. F. L = 22.07 ( $\pm 9.1^\circ$ )

\*\*\*1 = 24.411; \*\*\*2 = 8.679; \*\*\*3 = 6.140

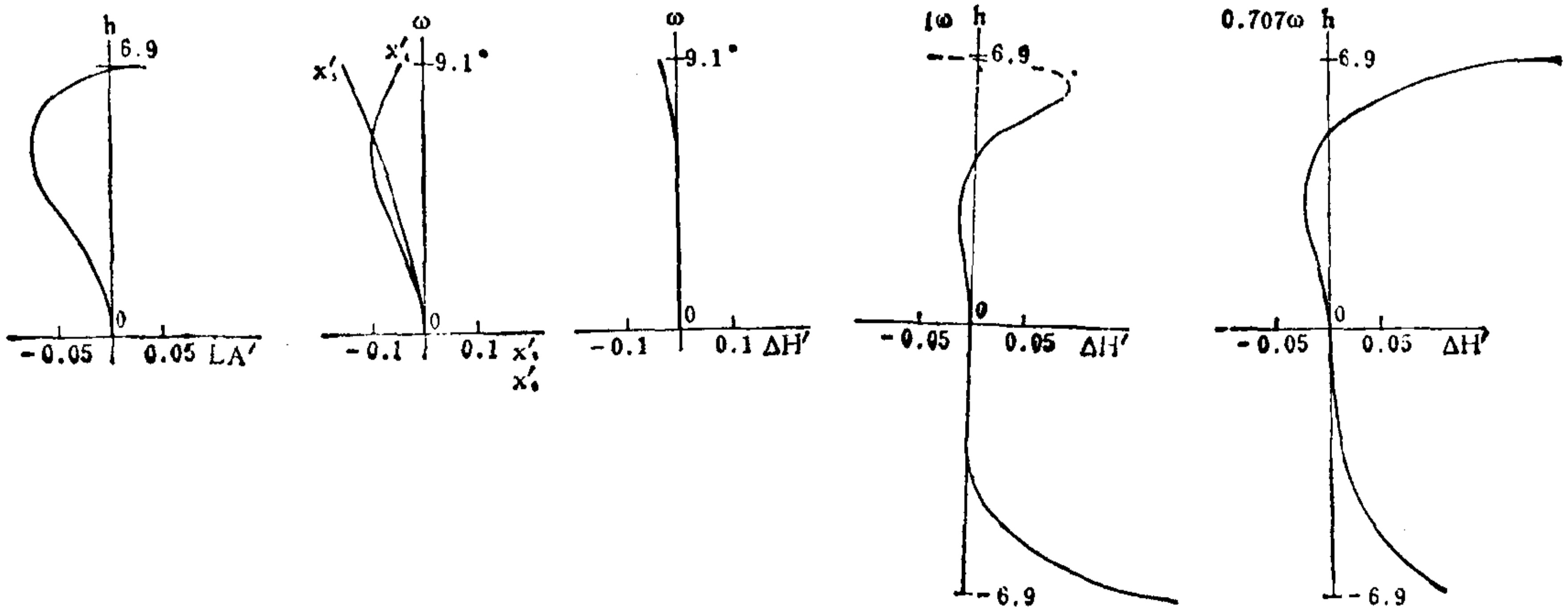

04-03-004-3

|                | $\Sigma S_1$ | $\Sigma S_2$ | $\Sigma S_3$ | $\Sigma S_4$ | $\Sigma S_5$ | HI        | QP(1 $\omega$ ) |
|----------------|--------------|--------------|--------------|--------------|--------------|-----------|-----------------|
|                | - 0.05572    | - 0.01061    | - 0.00823    | - 0.03001    | 0.02187      | 3.4       | 0.34%           |
| h 或 $\omega$ % | LA'          | $\Delta H'$  | $x'_t$       | $x_s$        | $x'_t - x_s$ | $K_{T1}$  | $K_{T0.7}$      |
| 100            | - 0.0073     | 0.0117       | - 0.0122     | - 0.1482     | 0.1360       | - 0.12645 | - 0.04408       |
| 70             | - 0.0883     | 0.0085       | - 0.0886     | - 0.0892     | 0.0006       | 0.11522   | - 0.00254       |

E. F. L = 34.30 ( $\pm 5.7^\circ$ )

\*\*\* 1 = 34.531, \*\*\* 2 = 3.500, \*\*\* 3 = 1.200

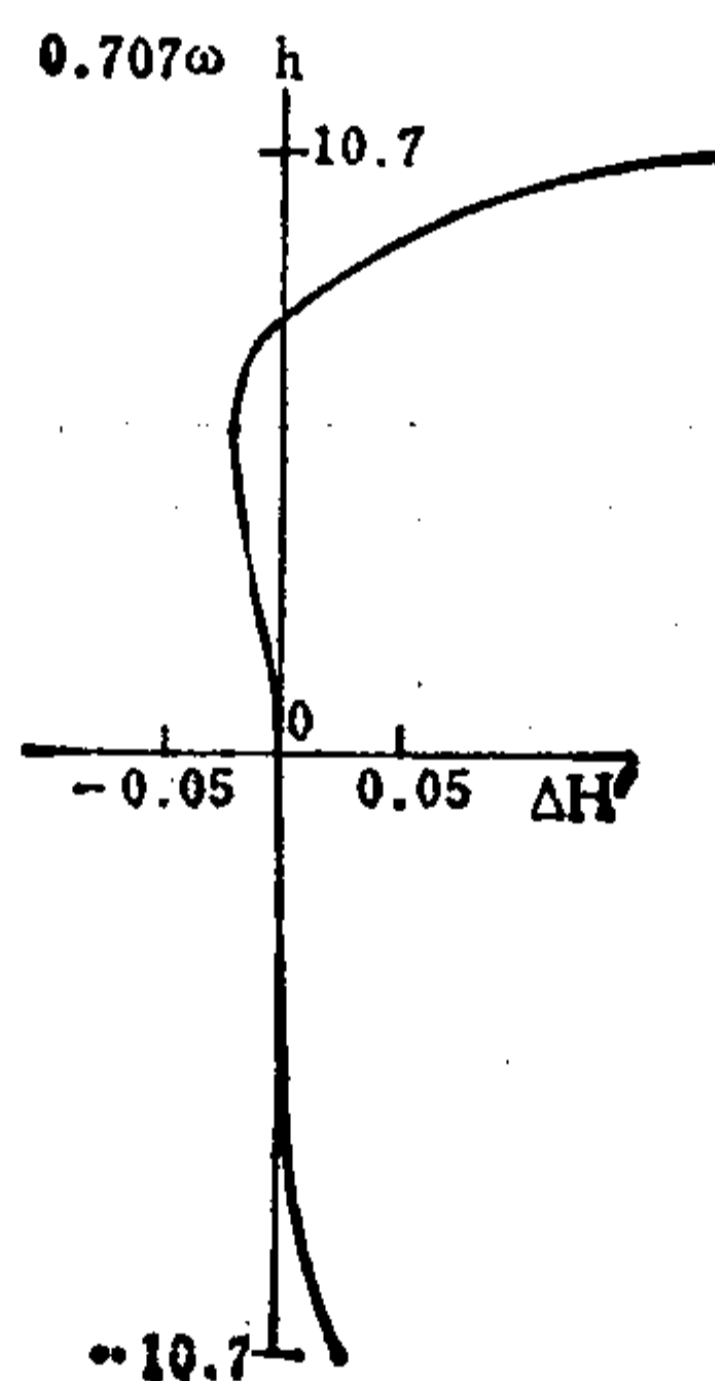
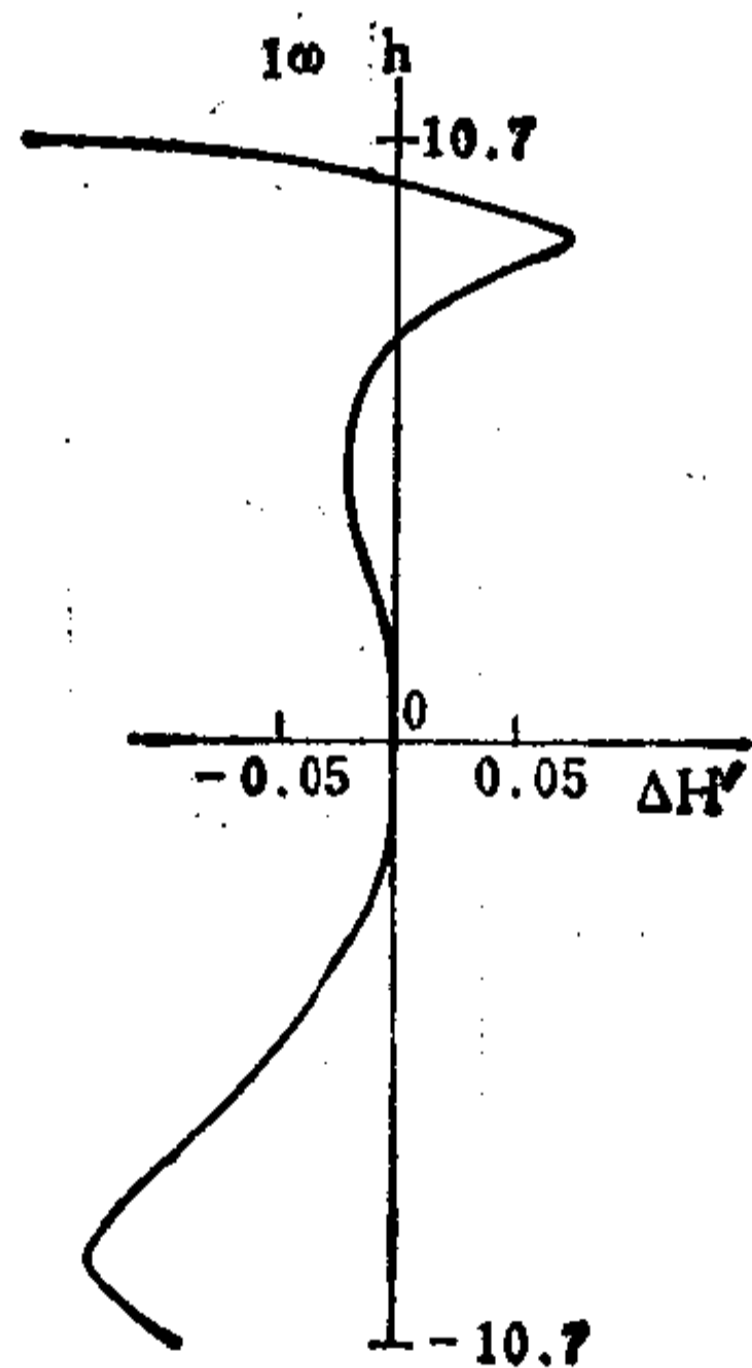
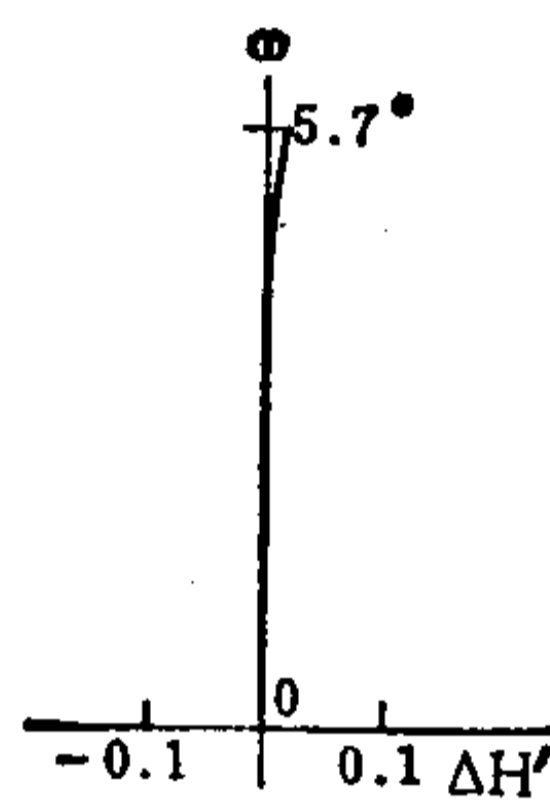
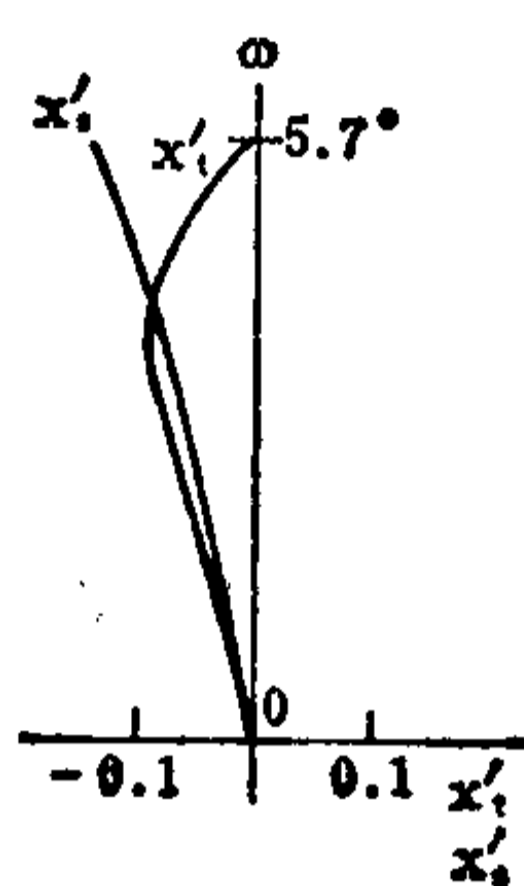
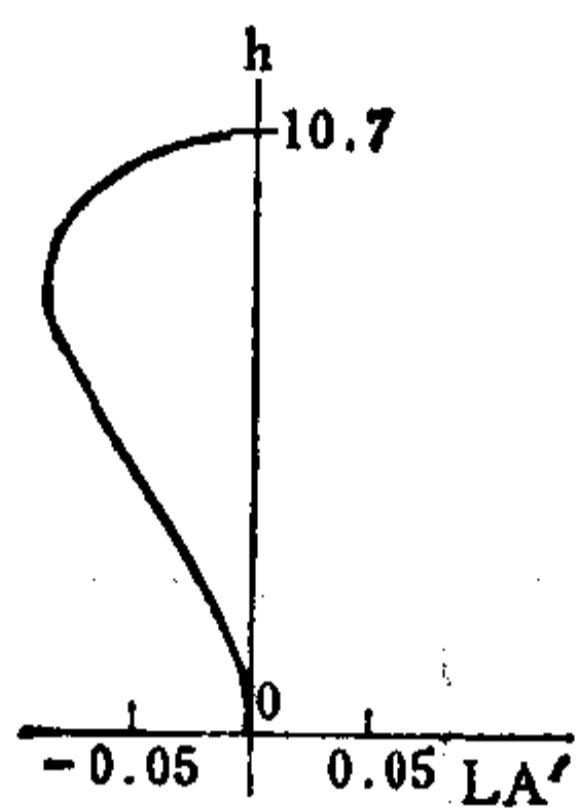

编号: 04-03-005

### 具有可动正组的变焦距物镜

E.F.L=15.65~24.70 B.F.L=7.74 FNo.=1.4 F.A.=±11°~±6.9°

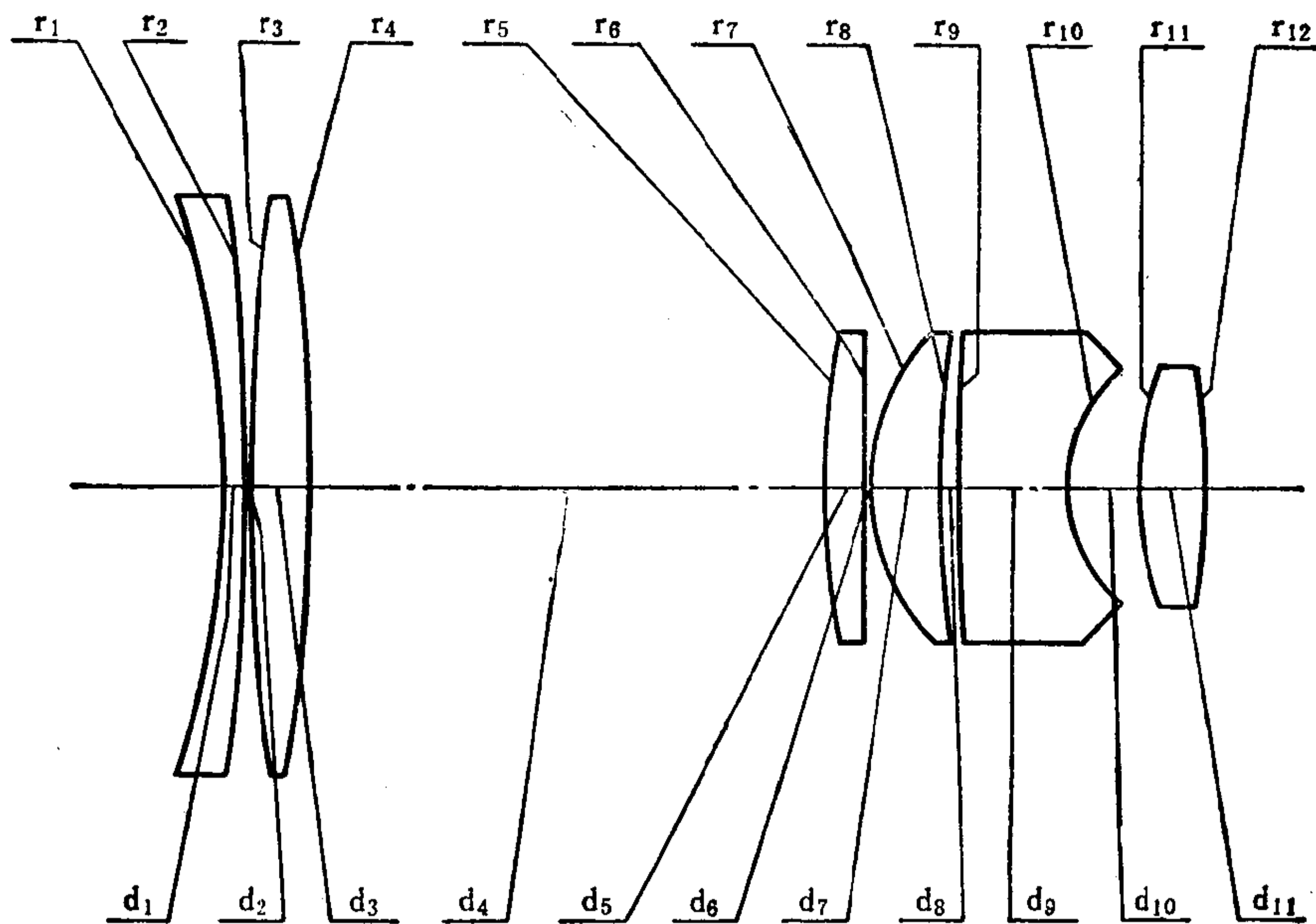

| 序号 | r         | d     | $n_d$   | $v_d$ | 序号 | r         | d     | $n_d$   | $v_d$ |
|----|-----------|-------|---------|-------|----|-----------|-------|---------|-------|
| 1  | - 39.6000 | 0.80  | 1.5111  | 63.4  | 7  | 9.8186    | 3.30  | 1.62041 | 60.3  |
| 2  | -111.7000 | *** 1 |         |       | 8  | 52.0000   | 0.60  |         |       |
| 3  | 84.0000   | 2.70  | 1.62041 | 60.3  | 9  | 400.0000  | 4.80  | 1.7618  | 27.0  |
| 4  | - 84.0000 | *** 2 |         |       | 10 | 6.8778    | 3.16* |         |       |
| 5  | 35.0000   | 1.80  | 1.62041 | 60.3  | 11 | 14.9628   | 2.70  | 1.6910  | 54.8  |
| 6  | $\infty$  | 0.15  |         |       | 12 | - 32.3126 |       |         |       |

3.16\* = 2.16 + 1.00

04-03-005-1

|                | $\Sigma S_1$ | $\Sigma S_2$ | $\Sigma S_3$ | $\Sigma S_4$ | $\Sigma S_5$  | HI       | QP(1 $\omega$ ) |
|----------------|--------------|--------------|--------------|--------------|---------------|----------|-----------------|
|                | -0.0335      | 0.0072       | 0.0087       | -0.0275      | -0.0362       | 3.04     | -1.95%          |
| h 或 $\omega$ % | LA'          | $\Delta H'$  | $x'_1$       | $x'_2$       | $x'_1 - x'_2$ | $K_{T1}$ | $K'_{T0.7}$     |
| 100            | 0.0568       | -0.0594      | 0.0099       | -0.0628      | 0.0727        | -0.2301  | -0.0114         |
| 70             | -0.0299      | -0.0196      | -0.0009      | -0.0353      | 0.0344        | -0.0997  | -0.0042         |

E. F. L = 15.66 ( $\pm 11^\circ$ )

\*\*\*1 = 31.70; \*\*\*2 = 0.30

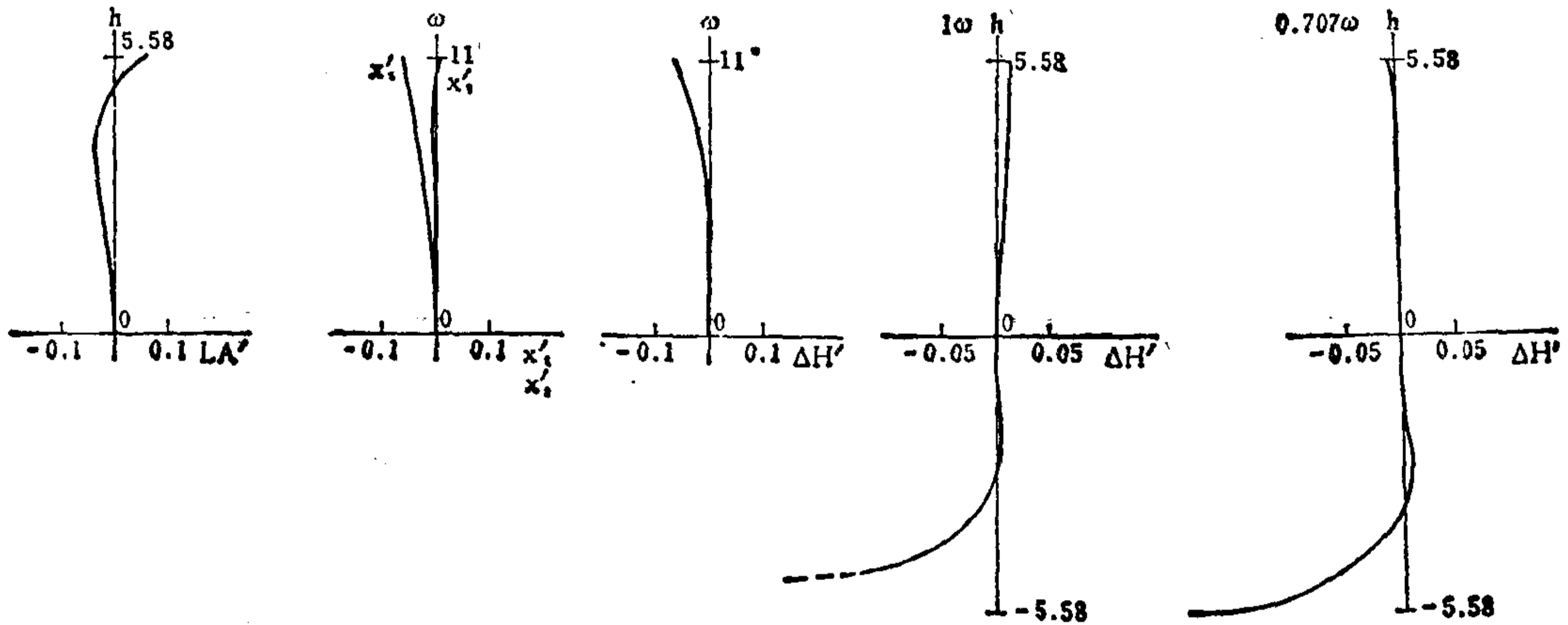

04-03-005-2

|                | $\Sigma S_1$ | $\Sigma S_2$ | $\Sigma S_3$ | $\Sigma S_4$ | $\Sigma S_5$  | HI        | QP(1 $\omega$ ) |
|----------------|--------------|--------------|--------------|--------------|---------------|-----------|-----------------|
|                | -0.0353      | 0.0087       | 0.0070       | -0.0268      | -0.0048       | 2.97      | -0.44%          |
| h 或 $\omega$ % | LA'          | $\Delta H'$  | $x'_1$       | $x'_2$       | $x'_1 - x'_2$ | $K'_{T1}$ | $K'_{T0.7}$     |
| 100            | 0.0448       | -0.0130      | -0.0003      | -0.0668      | 0.0665        | -0.1727   | -0.0056         |
| 70             | -0.0339      | -0.0035      | -0.0064      | -0.0366      | 0.0302        | -0.0827   | -0.0018         |

E. F. L = 19.68 ( $\pm 8.6^\circ$ )

\*\*\*1 = 16.00; \*\*\*2 = 16.00

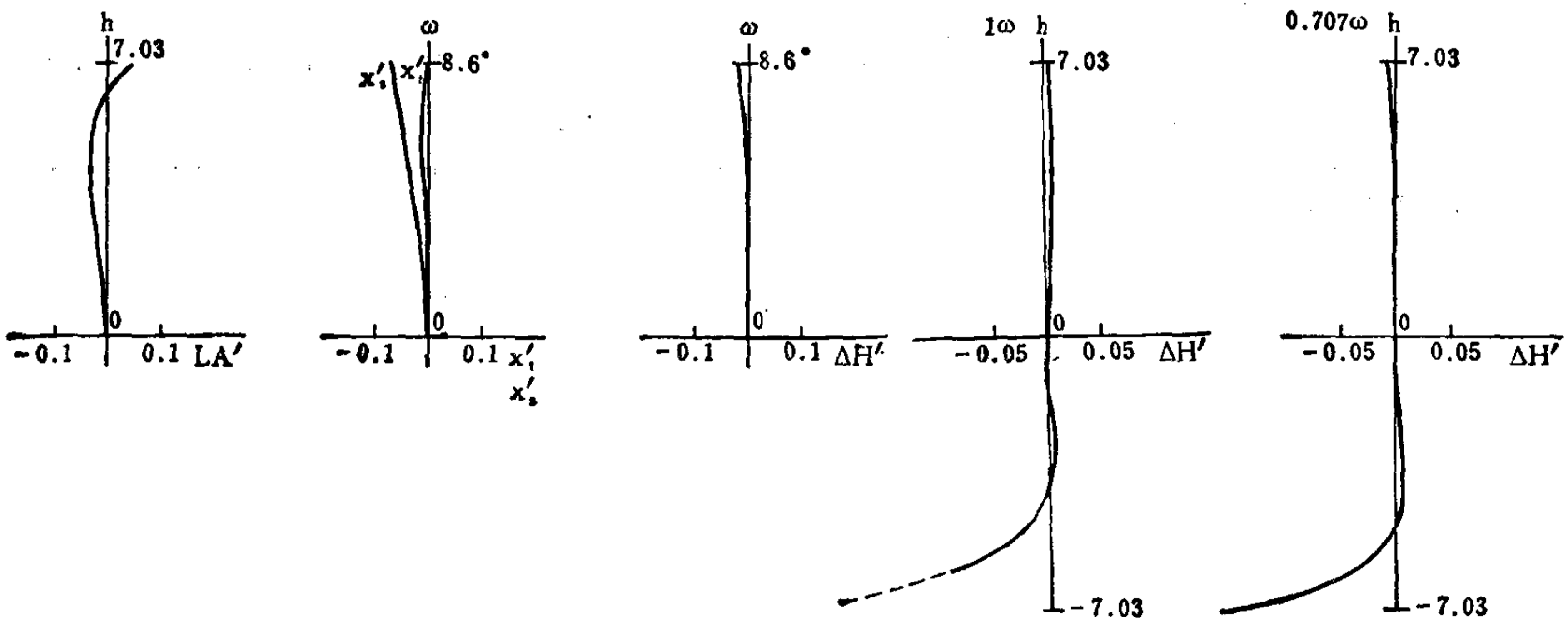

04-03-005-3

|                | $\Sigma S_1$ | $\Sigma S_2$ | $\Sigma S_3$ | $\Sigma S_4$ | $\Sigma S_5$  | HI        | QP(1 $\omega$ ) |
|----------------|--------------|--------------|--------------|--------------|---------------|-----------|-----------------|
|                | -0.0358      | 0.0076       | 0.0107       | -0.0270      | 0.0052        | 2.98      | -0.001%         |
| h 或 $\omega$ % | LA'          | $\Delta H'$  | $x'_t$       | $x'_s$       | $x'_t - x'_s$ | $K'_{T1}$ | $K'_{T0.7}$     |
| 100            | 0.0433       | -0.00004     | 0.0535       | -0.0515      | 0.1050        | -0.1889   | -0.0097         |
| 70             | -0.0356      | 0.00130      | 0.0185       | -0.0292      | 0.0477        | -0.0898   | -0.0042         |

E. F. L = 24.7 ( $\pm 6.9^\circ$ )

\*\*\*1 = 0.3, \*\*\*2 = 31.7

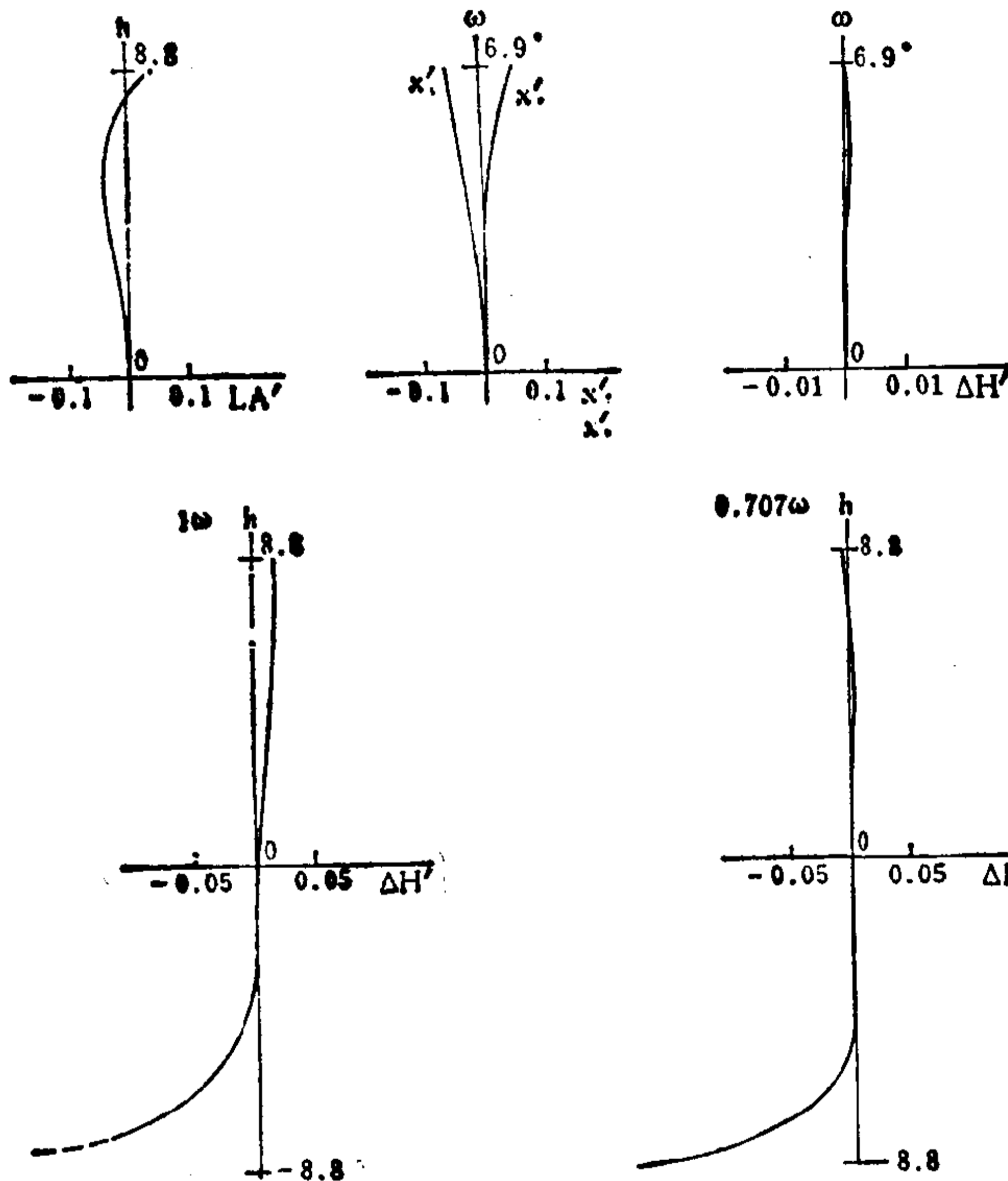

编号: 04-03-006

# 八片式变焦距物镜

E.F.L.=0.751~1.253 B.F.L= FNo.=1.1 F.A.=±11.5°~±6.8°

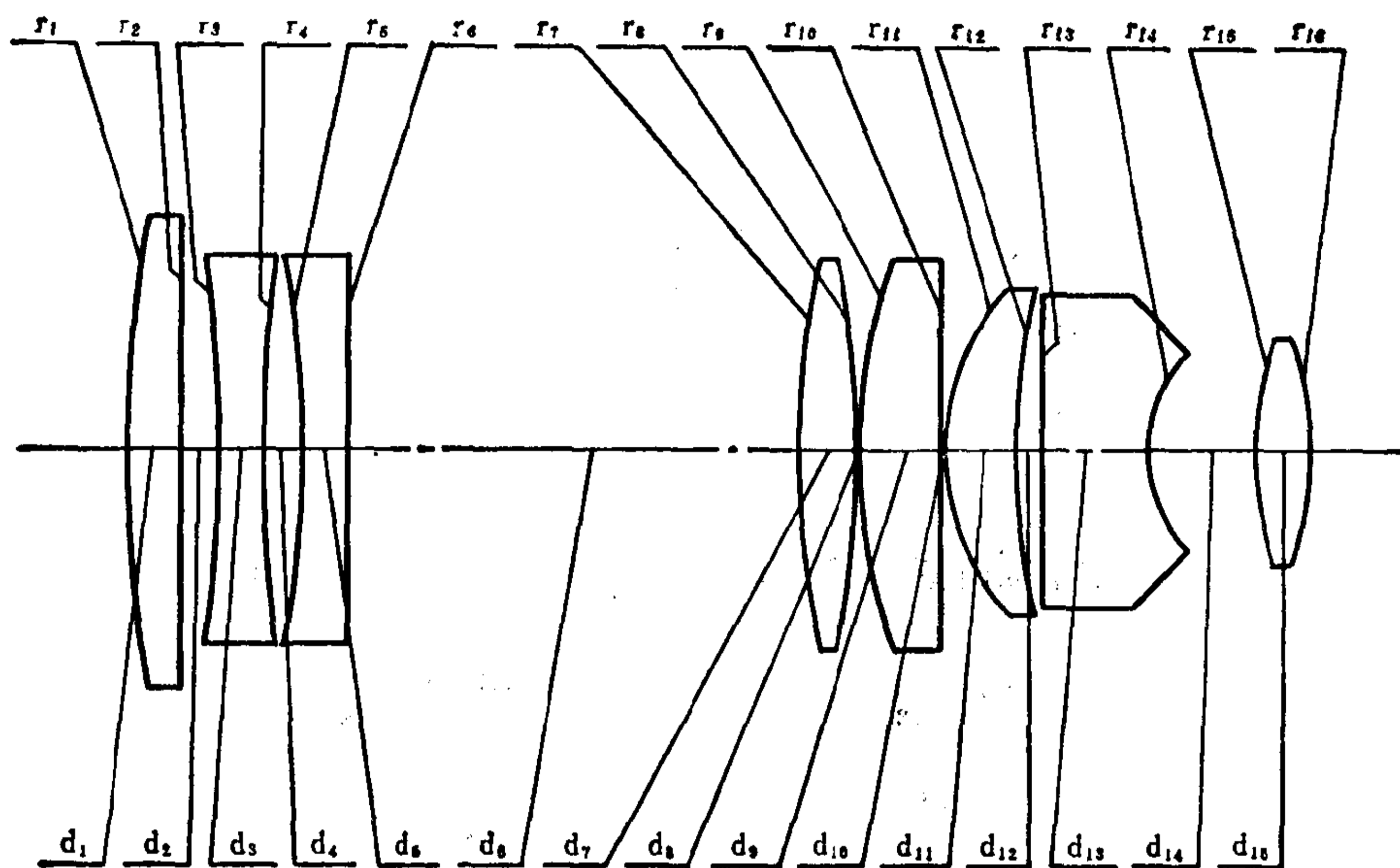

| 序号 | r         | d       | n <sub>d</sub> | v <sub>d</sub> | 序号 | r         | d        | n <sub>d</sub> | v <sub>d</sub> |
|----|-----------|---------|----------------|----------------|----|-----------|----------|----------------|----------------|
| 1  | 3.10878   | 0.12500 | 1.56873        | 63.12          | 9  | 1.41669   | 0.19000  | 1.62041        | 60.29          |
| 2  | ∞         | *** 1   |                |                | 10 | ∞         | 0.00500  |                |                |
| 3  | - 3.54321 | 0.10947 | 1.51680        | 64.20          | 11 | 0.56300   | 0.16880  | 1.62041        | 60.29          |
| 4  | 3.54321   | 0.07900 |                |                | 12 | 2.02380   | 0.04621  |                |                |
| 5  | - 2.37372 | 0.10947 | 1.51680        | 64.20          | 13 | ∞         | 0.25475  | 1.78470        | 26.10          |
| 6  | ∞         | *** 2   |                |                | 14 | 0.33093   | 0.25194* |                |                |
| 7  | 2.25261   | 0.13673 | 1.56873        | 63.12          | 15 | 0.82575   | 0.13000  | 1.75496        | 53.28          |
| 8  | - 2.25261 | 0.00800 |                |                | 16 | - 0.82575 |          |                |                |

0.25194\* = 0.10000 + 0.15194

04-03-006-1

|                | $\Sigma S_1$ | $\Sigma S_2$ | $\Sigma S_3$ | $\Sigma S_4$ | $\Sigma S_5$  | HI        | QP(1 $\omega$ ) |
|----------------|--------------|--------------|--------------|--------------|---------------|-----------|-----------------|
|                | - 0.00214    | - 0.00024    | 0.00088      | - 0.00263    | - 0.00177     | 0.15      | - 1.41%         |
| h 或 $\omega$ % | LA'          | $\Delta H'$  | $x'_t$       | $x'_s$       | $x'_t - x'_s$ | $K'_{T1}$ | $K'_{T0.7}$     |
| 100            | - 0.00169    | - 0.00214    | - 0.00153    | - 0.00379    | 0.00226       | 0.01277   | 0.00327         |
| 70             | - 0.00177    | - 0.00073    | - 0.00025    | - 0.00201    | 0.00176       | 0.00609   | 0.00107         |

E. F. L = 0.751 ( $\pm 11.5^\circ$ )    B. F. L = 0.292

\*\*\* 1 = 0.08749; \*\*\* 2 = 1.08023

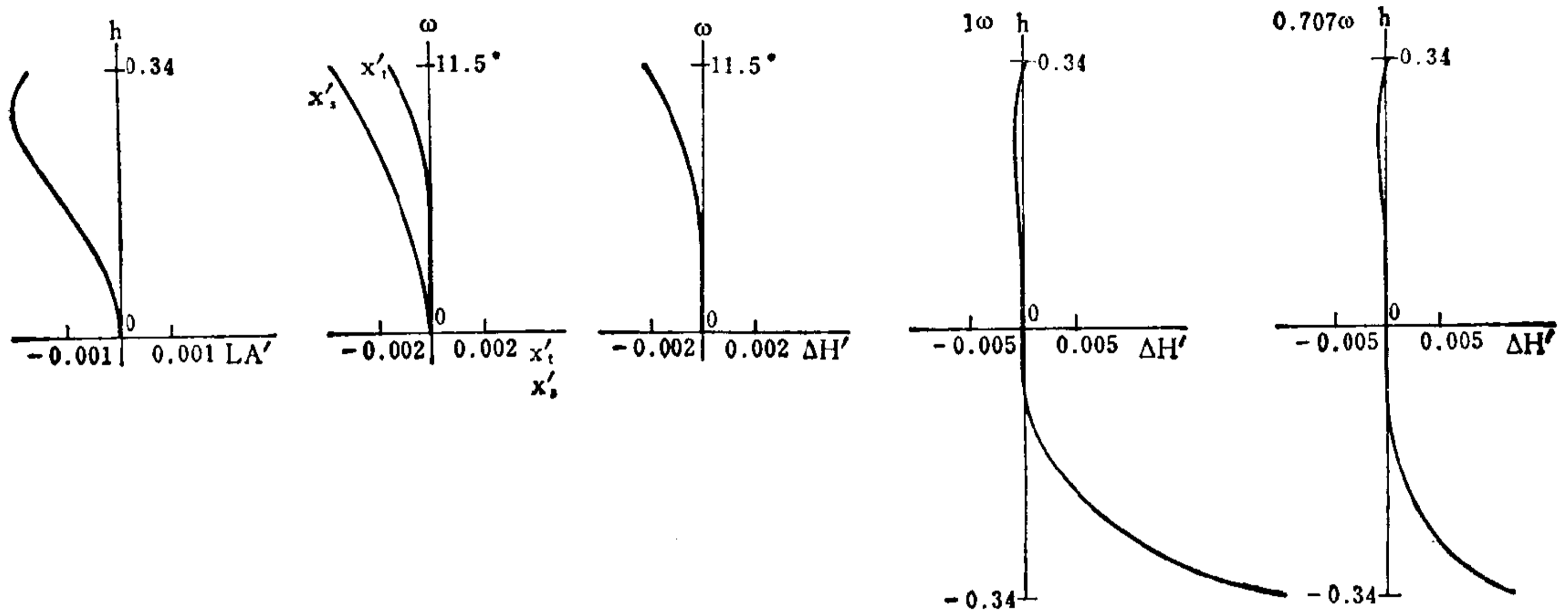

04-03-006-2

|                | $\Sigma S_1$ | $\Sigma S_2$ | $\Sigma S_3$ | $\Sigma S_4$ | $\Sigma S_5$  | HI        | QP(1 $\omega$ ) |
|----------------|--------------|--------------|--------------|--------------|---------------|-----------|-----------------|
|                | - 0.00259    | - 0.00044    | 0.00138      | - 0.00261    | 0.00001       | 0.15      | - 0.09%         |
| h 或 $\omega$ % | LA'          | $\Delta H'$  | $x'_t$       | $x'_s$       | $x'_t - x'_s$ | $K'_{T1}$ | $K'_{T0.7}$     |
| 100            | - 0.00151    | - 0.00014    | 0.00291      | - 0.00256    | 0.00547       | 0.00943   | 0.00181         |
| 70             | - 0.00219    | - 0.00002    | 0.00175      | - 0.00141    | 0.00316       | 0.00467   | 0.00050         |

E. F. L = 1.000 ( $\pm 8.6^\circ$ )    B. F. L = 0.313

\*\*\* 1 = 0.68768; \*\*\* 2 = 0.48004

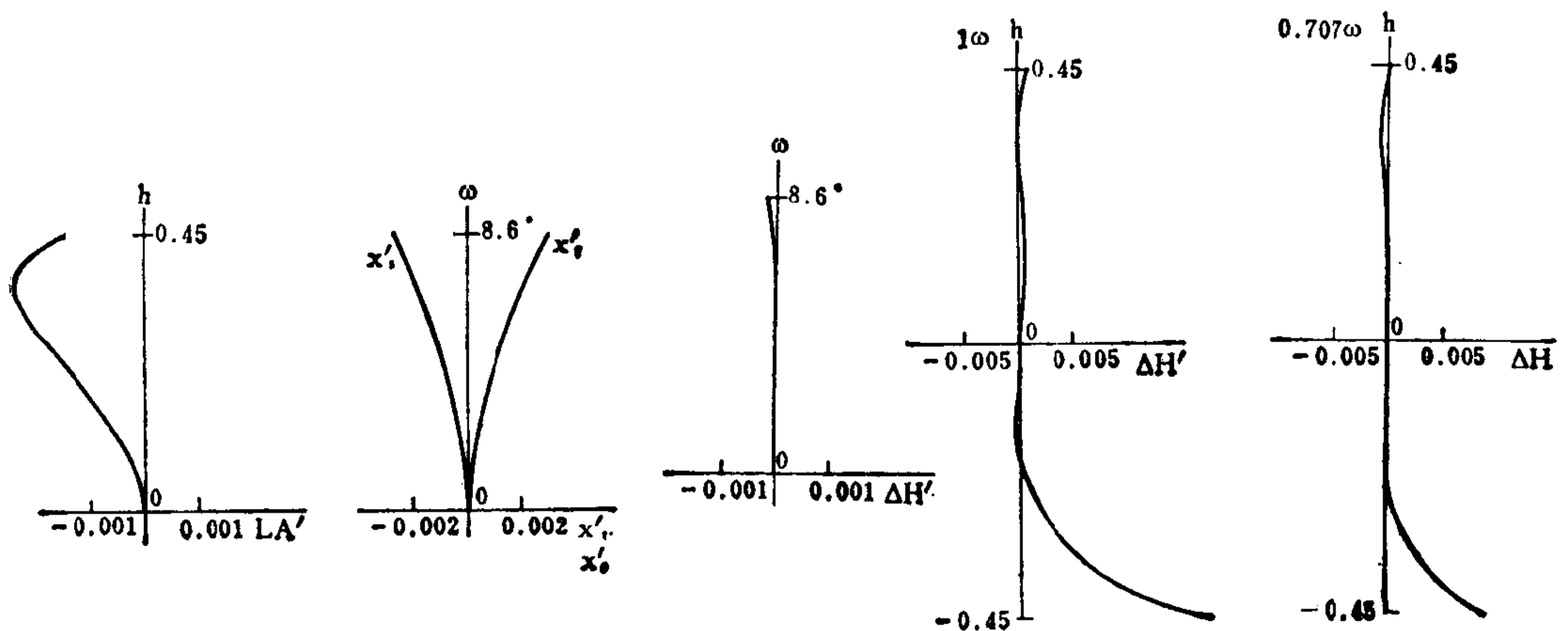



|                | $\Sigma S_1$ | $\Sigma S_2$ | $\Sigma S_3$ | $\Sigma S_4$ | $\Sigma S_5$  | HI        | QP(1 $\omega$ ) |
|----------------|--------------|--------------|--------------|--------------|---------------|-----------|-----------------|
|                | - 0.00275    | - 0.00069    | 0.00161      | - 0.00268    | 0.00103       | 0.15      | 0.68%           |
| h 或 $\omega$ % | LA'          | $\Delta H'$  | $x'_t$       | $x'_s$       | $x'_t - x'_s$ | $K'_{T1}$ | $K'_{T0.7}$     |
| 100            | - 0.00017    | 0.00102      | 0.00454      | - 0.00215    | 0.00670       | 0.00787   | 0.00096         |
| 70             | - 0.00211    | 0.00039      | 0.00244      | - 0.00122    | 0.00366       | 0.00391   | 0.00009         |

E. F. L = 1.253 ( $\pm 6.8^\circ$ )    B. F. L = 0.324

\*\*\* 1 = 1.12772, \*\*\* 2 = 0.04000

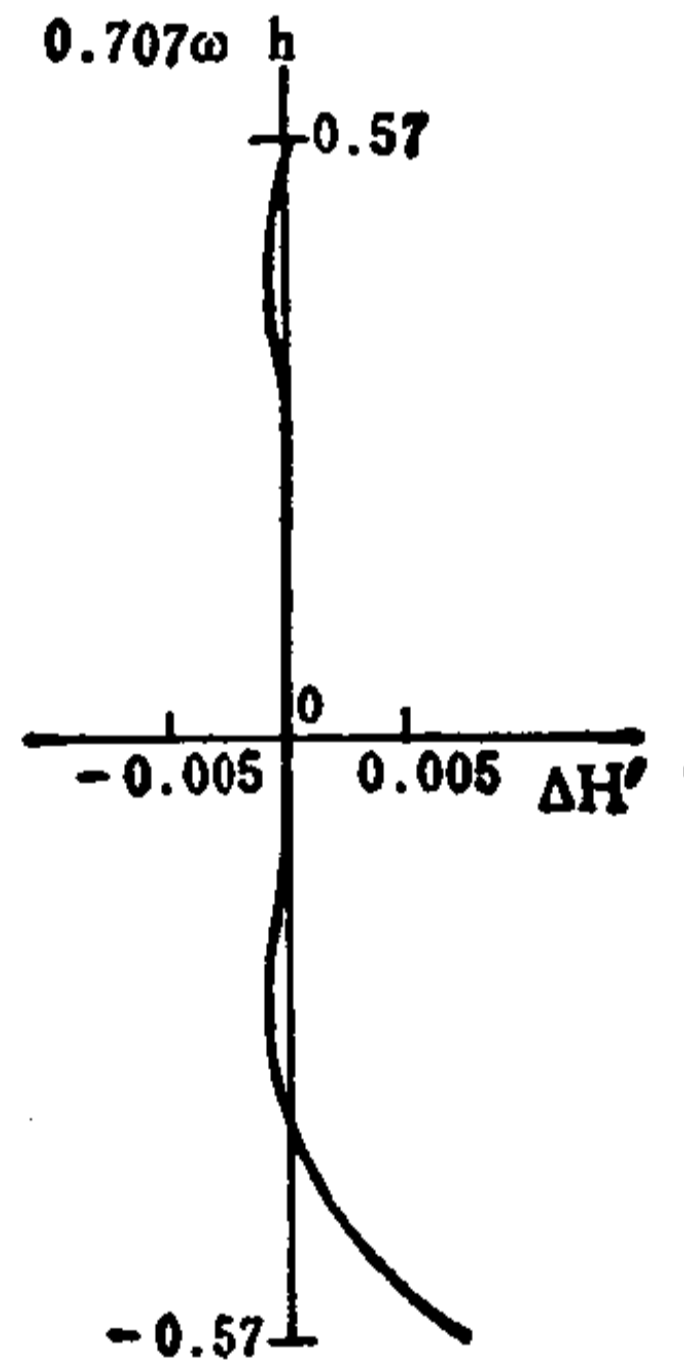
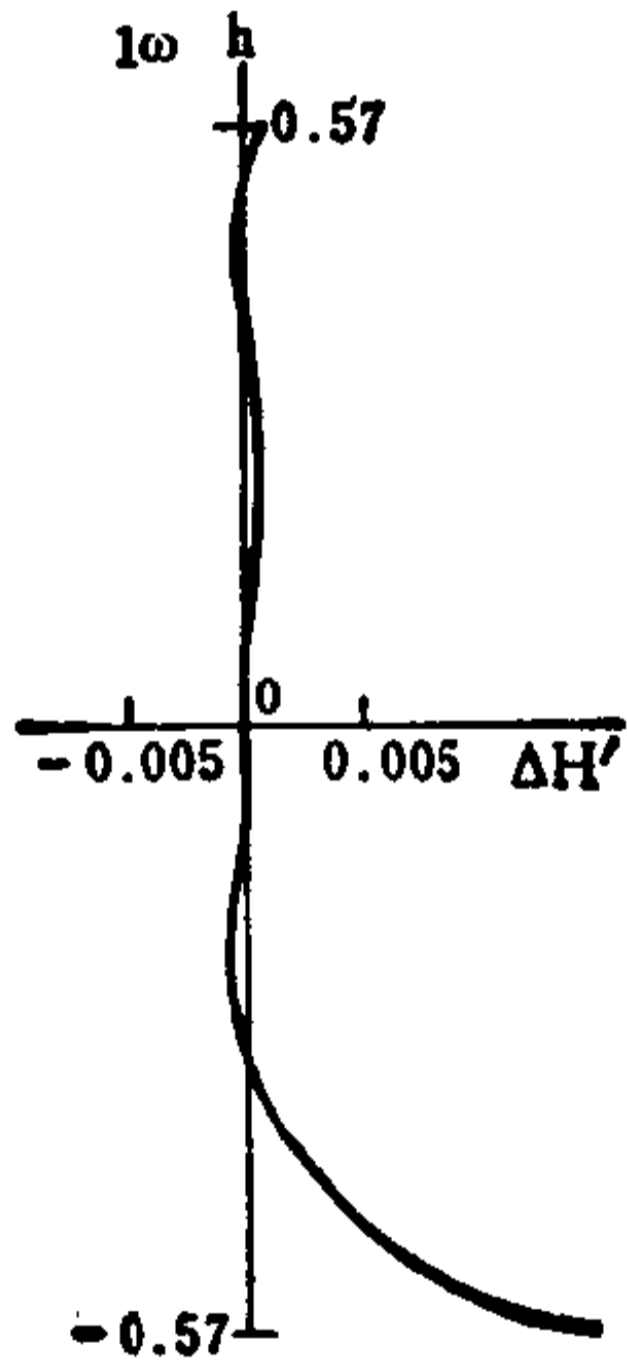
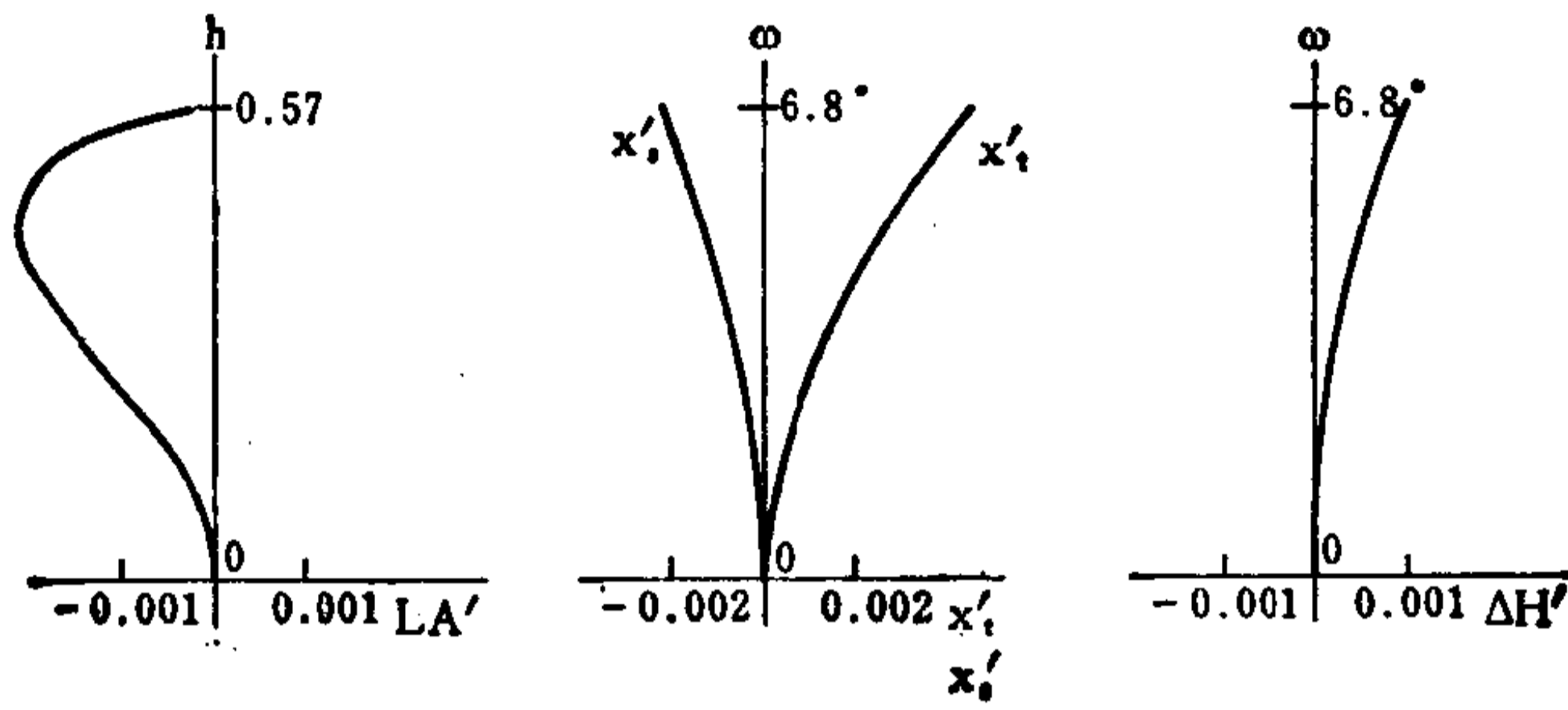

编号: 04-03-007

## 变 焦 距 镜 头

E. F. L = 9.95 ~ 22.42    B. F. L = 7.1    FNo. = 2.7    F. A. =  $\pm 20^\circ \sim \pm 8.9^\circ$

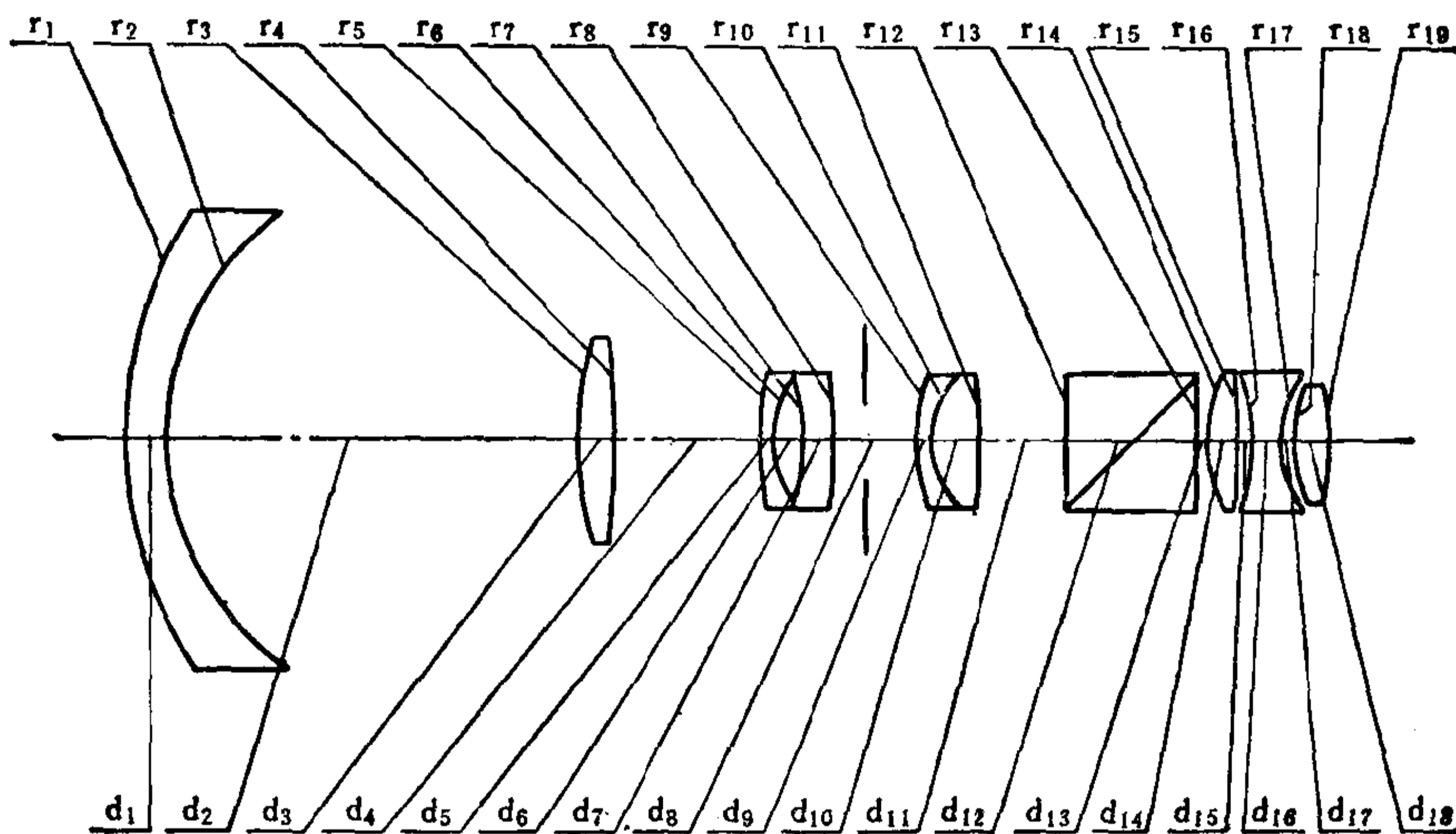

| 序号 | r        | d      | n    | v    | 序号 | r        | d     | n    | v    |
|----|----------|--------|------|------|----|----------|-------|------|------|
| 1  | 35.60    | 3.48   | 1.50 | 67.0 | 11 | - 62.90  | *** 3 |      |      |
| 2  | 24.10    | 36.02  |      |      | 12 | $\infty$ | 11.13 | 1.49 | 57.4 |
| 3  | 32.60    | 2.73   | 1.64 | 60.1 | 13 | $\infty$ | 0.85  |      |      |
| 4  | - 103.60 | *** 1  |      |      | 14 | 13.20    | 2.58  | 1.69 | 56.2 |
| 5  | 51.80    | 0.90   | 1.50 | 67.0 | 15 | - 267.80 | 0.93  |      |      |
| 6  | 9.27     | 2.17   |      |      | 16 | - 19.30  | 2.73  | 1.62 | 36.6 |
| 7  | - 19.40  | 2.92   | 1.50 | 67.0 | 17 | 9.56     | 0.83  |      |      |
| 8  | - 54.80  | *** 2* |      |      | 18 | 12.90    | 2.96  | 1.61 | 58.8 |
| 9  | 16.40    | 0.97   | 1.72 | 29.3 | 19 | - 33.40  |       |      |      |
| 10 | 7.92     | 4.37   | 1.66 | 50.8 |    |          |       |      |      |

04-03-007-1

|                | $\Sigma S_1$ | $\Sigma S_2$ | $\Sigma S_3$ | $\Sigma S_4$ | $\Sigma S_5$  | HI        | QP(1 $\odot$ ) |
|----------------|--------------|--------------|--------------|--------------|---------------|-----------|----------------|
|                | -0.0135      | -0.0063      | 0.0008       | -0.0052      | -0.0419       | 3.65      | -3.1%          |
| h 或 $\omega$ % | LA'          | $\Delta H'$  | $x_t$        | $x'_s$       | $x'_t - x'_s$ | $K'_{T1}$ | $K'_{T0.7}$    |
| 100            | -0.170       | -0.111       | -0.006       | -0.068       | 0.062         | 0.0250    | 0.0002         |
| 70             | -0.094       | -0.042       | -0.038       | -0.042       | 0.004         | -0.0079   | -0.0106        |

E. F. L = 10.00 ( $\pm 20^\circ$ )

\*\*\*1=3.06; \*\*\*2=24.94; \*\*\*3=2.02; \*\*\*2\* = 24.94 = 17.74 + 7.20

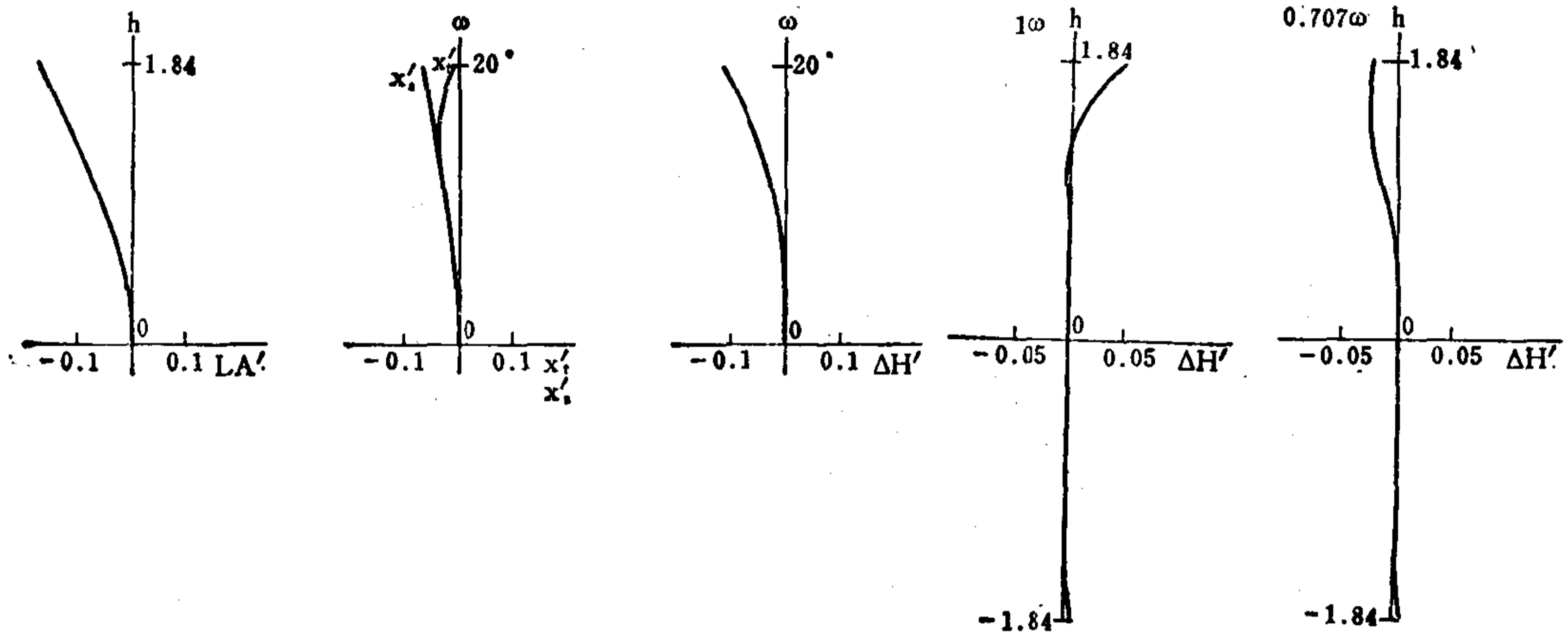

04-03-007-2

|                | $\Sigma S_1$ | $\Sigma S_2$ | $\Sigma S_3$ | $\Sigma S_4$ | $\Sigma S_5$  | HI        | QP(1 $\omega$ ) |
|----------------|--------------|--------------|--------------|--------------|---------------|-----------|-----------------|
|                | -0.0053      | 0.0001       | -0.0036      | -0.0054      | 0.0091        | 3.55      | 1.06%           |
| h 或 $\omega$ % | LA'          | $\Delta H'$  | $x'_t$       | $x'_s$       | $x'_t - x'_s$ | $K'_{T1}$ | $K'_{T0.7}$     |
| 100            | 0.0228       | 0.0377       | -0.124       | -0.108       | -0.016        | 0.0651    | 0.0213          |
| 70             | -0.0217      | 0.0106       | -0.096       | -0.062       | -0.034        | 0.0303    | 0.0082          |

E. F. L = 22.60 ( $\pm 8.9^\circ$ )

\*\*\*1=13.28; \*\*\*2=9.05; \*\*\*3=7.67; \*\*\*2\* = 9.05 = 7.52 + 1.53

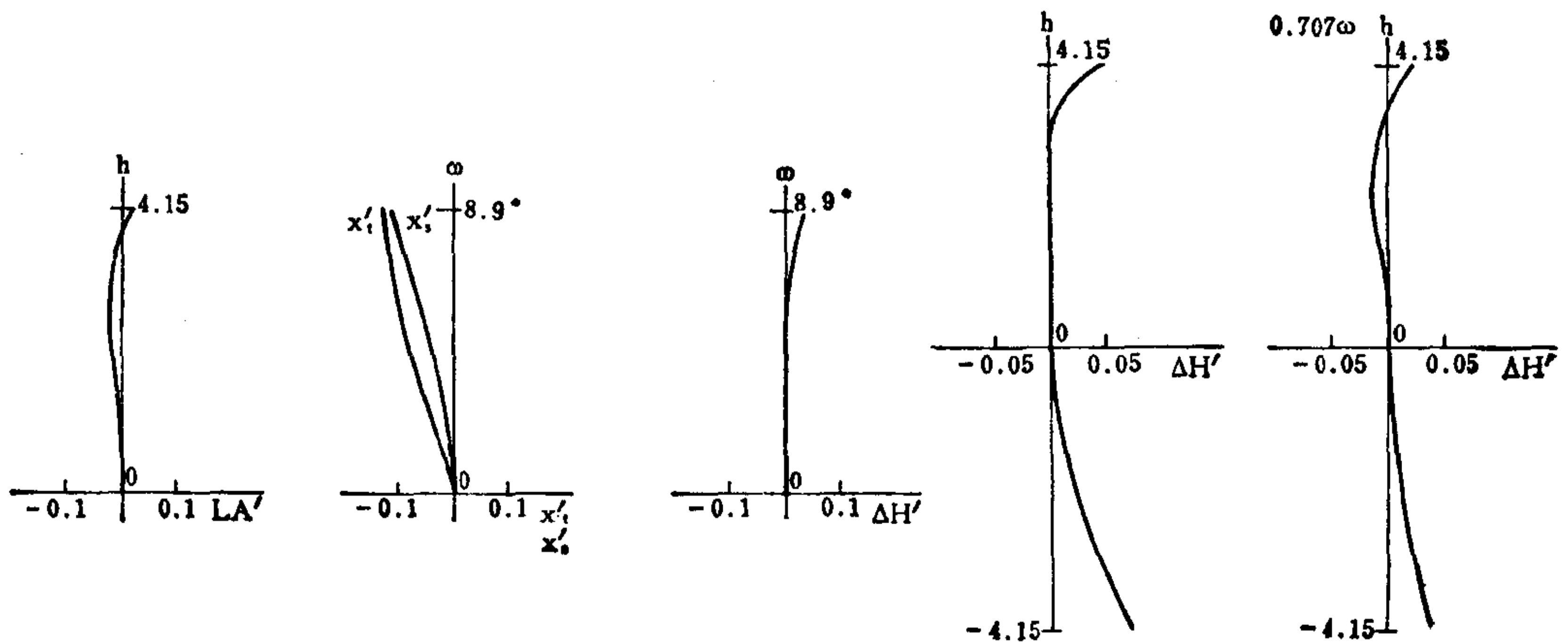

编号: 04-03-008

# 八片式变焦距物镜

E.F.L=0.747~1.248    B.F.L= FNo. =1.1    F.A. = ±11.5° ~ ±6.8°

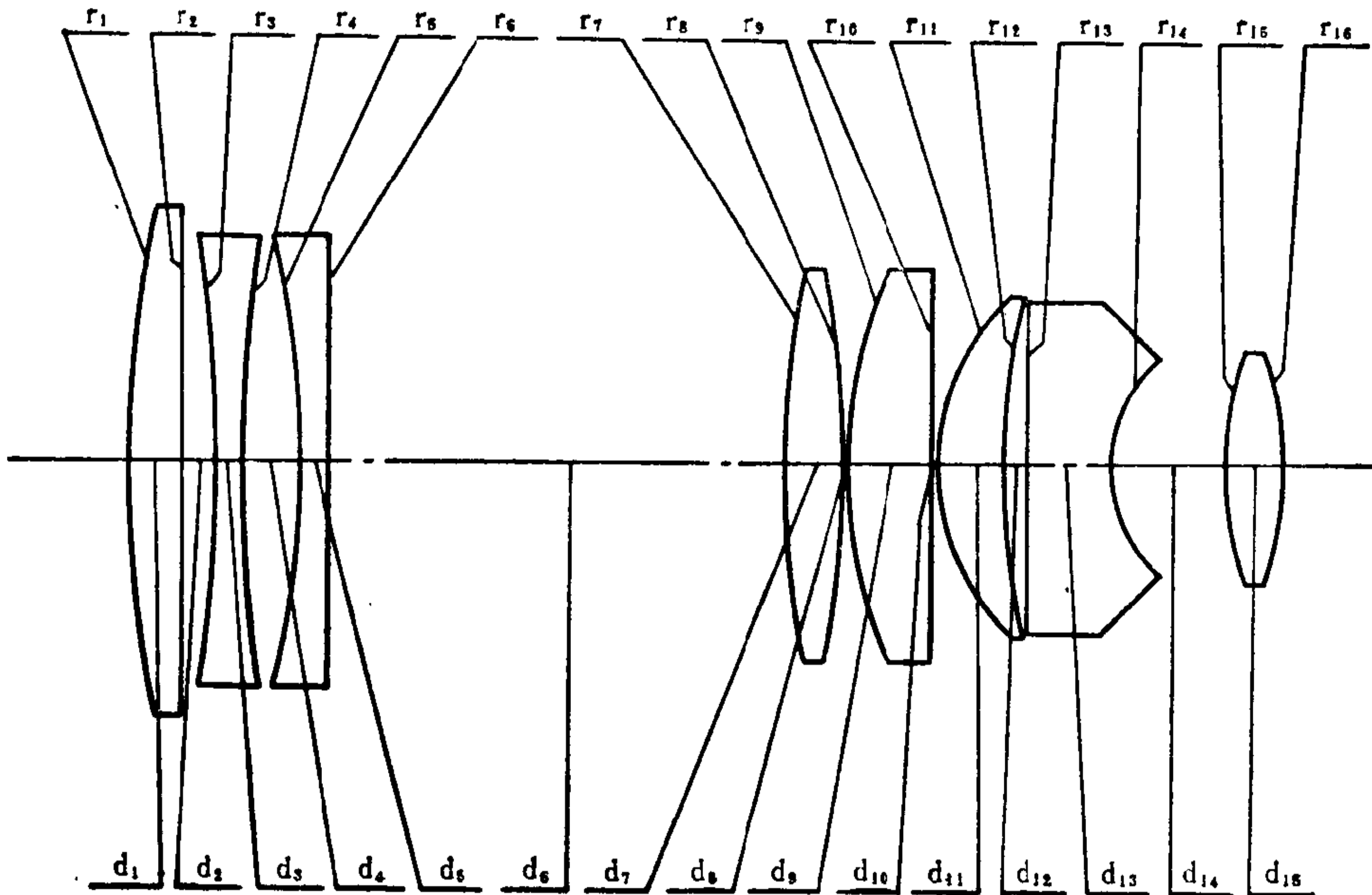

| 序号 | r         | d       | n <sub>d</sub> | v <sub>d</sub> | 序号 | r         | d        | n <sub>d</sub> | v <sub>d</sub> |
|----|-----------|---------|----------------|----------------|----|-----------|----------|----------------|----------------|
| 1  | 3.17793   | 0.12500 | 1.56873        | 63.12          | 9  | 1.16025   | 0.21000  | 1.62041        | 60.29          |
| 2  | ∞         | *** 1   |                |                | 10 | ∞         | 0.00500  |                |                |
| 3  | - 3.84882 | 0.07250 | 1.51680        | 64.20          | 11 | 0.56300   | 0.16480  | 1.62041        | 60.29          |
| 4  | 3.84882   | 0.12791 |                |                | 12 | 2.14680   | 0.04621  |                |                |
| 5  | - 2.31809 | 0.07250 | 1.51680        | 64.20          | 13 | ∞         | 0.19700  | 1.78470        | 26.10          |
| 6  | ∞         | *** 2   |                |                | 14 | 0.34065   | 0.28051* |                |                |
| 7  | 2.51876   | 0.13673 | 1.56873        | 63.12          | 15 | 0.86810   | 0.13000  | 1.75496        | 53.28          |
| 8  | - 2.51876 | 0.00800 |                |                | 16 | - 0.86810 |          |                |                |

0.28051\* = 0.10000 + 0.18051

04-03-003-1

|                | $\Sigma S_1$ | $\Sigma S_2$ | $\Sigma S_3$ | $\Sigma S_4$ | $\Sigma S_5$  | HI        | QP(1 $\omega$ ) |
|----------------|--------------|--------------|--------------|--------------|---------------|-----------|-----------------|
|                | - 0.00248    | 0.00005      | 0.00052      | - 0.00278    | - 0.00178     | 0.151     | - 1.4%          |
| h 或 $\omega$ % | LA'          | $\Delta H'$  | $x'_t$       | $x'_s$       | $x'_t - x'_s$ | $K'_{T1}$ | $K'_{T0.7}$     |
| 100            | - 0.0012     | - 0.0021     | - 0.0036     | - 0.0049     | 0.0013        | 0.00578   | 0.00175         |
| 70             | - 0.0019     | - 0.0007     | - 0.0016     | - 0.0026     | 0.0010        | 0.00336   | 0.00073         |

E. F. L = 0.747( $\pm 11.5^\circ$ ) B. F. L = 0.296

\*\*\* 1 = 0.07800; \*\*\* 2 = 1.11451

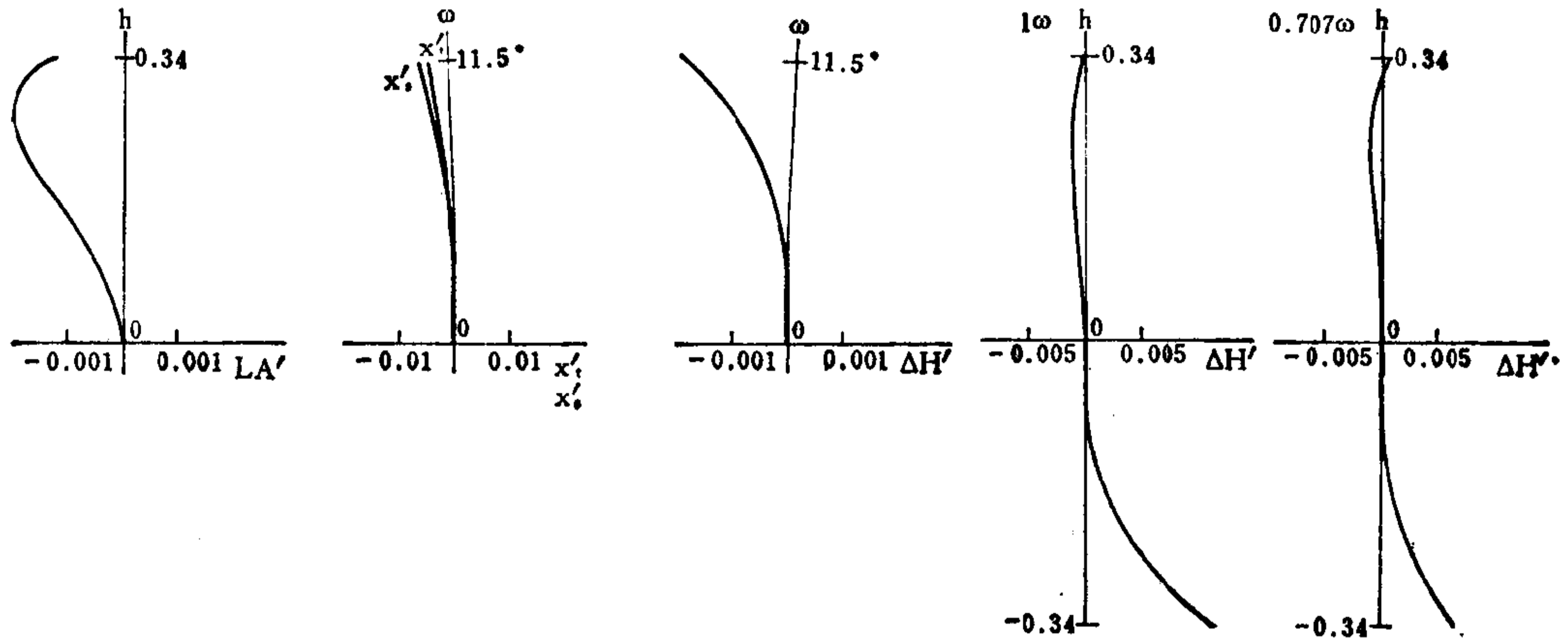

04-03-008-2

|                | $\Sigma S_1$ | $\Sigma S_2$ | $\Sigma S_3$ | $\Sigma S_4$ | $\Sigma S_5$  | HI        | QP(1 $\omega$ ) |
|----------------|--------------|--------------|--------------|--------------|---------------|-----------|-----------------|
|                | - 0.00295    | - 0.00021    | 0.00097      | - 0.00280    | 0.00021       | 0.15      | 0.06%           |
| h 或 $\omega$ % | LA'          | $\Delta H'$  | $x'_t$       | $x'_s$       | $x'_t - x'_s$ | $K'_{T1}$ | $K'_{T0.7}$     |
| 100            | - 0.0009     | 0.000095     | 0.00020      | - 0.00390    | 0.00410       | 0.00350   | 0.00060         |
| 70             | - 0.0023     | 0.000059     | 0.00016      | - 0.00210    | 0.00226       | 0.00232   | 0.00018         |

E. F. L = 0.998( $\pm 8.6^\circ$ ) B. F. L = 0.316

\*\*\* 1 = 0.69769; \*\*\* 2 = 0.49481

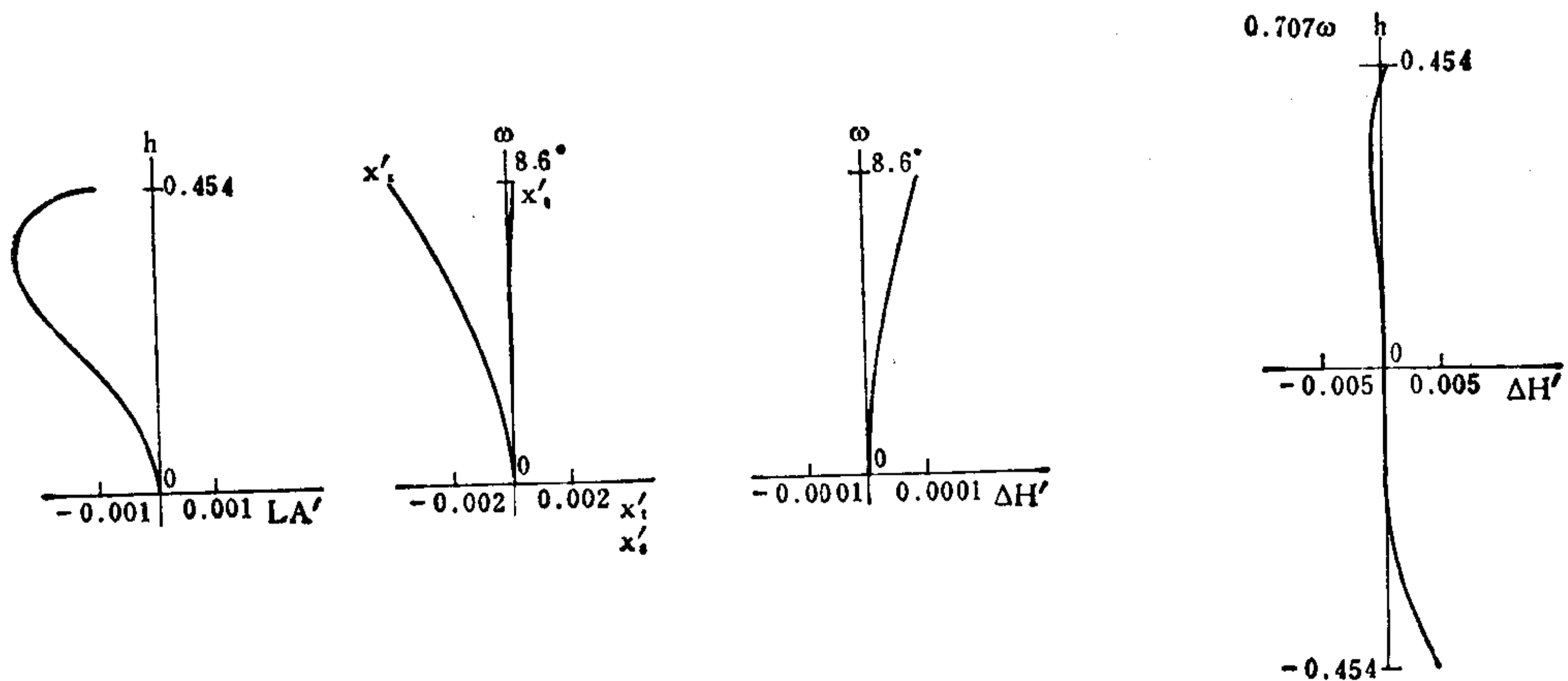

04-03-008-3

|                | $\Sigma S_1$ | $\Sigma S_2$ | $\Sigma S_3$ | $\Sigma S_4$ | $\Sigma S_5$  | HI        | QP(1 $\omega$ ) |
|----------------|--------------|--------------|--------------|--------------|---------------|-----------|-----------------|
|                | - 0.00278    | - 0.00046    | 0.00108      | - 0.00274    | 0.00132       | 0.15      | 0.92%           |
| h 或 $\omega$ % | LA'          | $\Delta H'$  | $x'_t$       | $x'_s$       | $x'_t - x'_s$ | $K'_{T1}$ | $K'_{T0.7}$     |
| 100            | - 0.0003     | 0.0013       | 0.00130      | - 0.00370    | 0.00500       | 0.00167   | - 0.00023       |
| 70             | - 0.0021     | 0.0005       | 0.00065      | - 0.00197    | 0.00262       | 0.00120   | - 0.00026       |

E. F. L = 1.248 ( $\pm 6.8^\circ$ )    B. F. L = 0.326

\*\*\*1 = 1.15251; \*\*\*2 = 0.04000

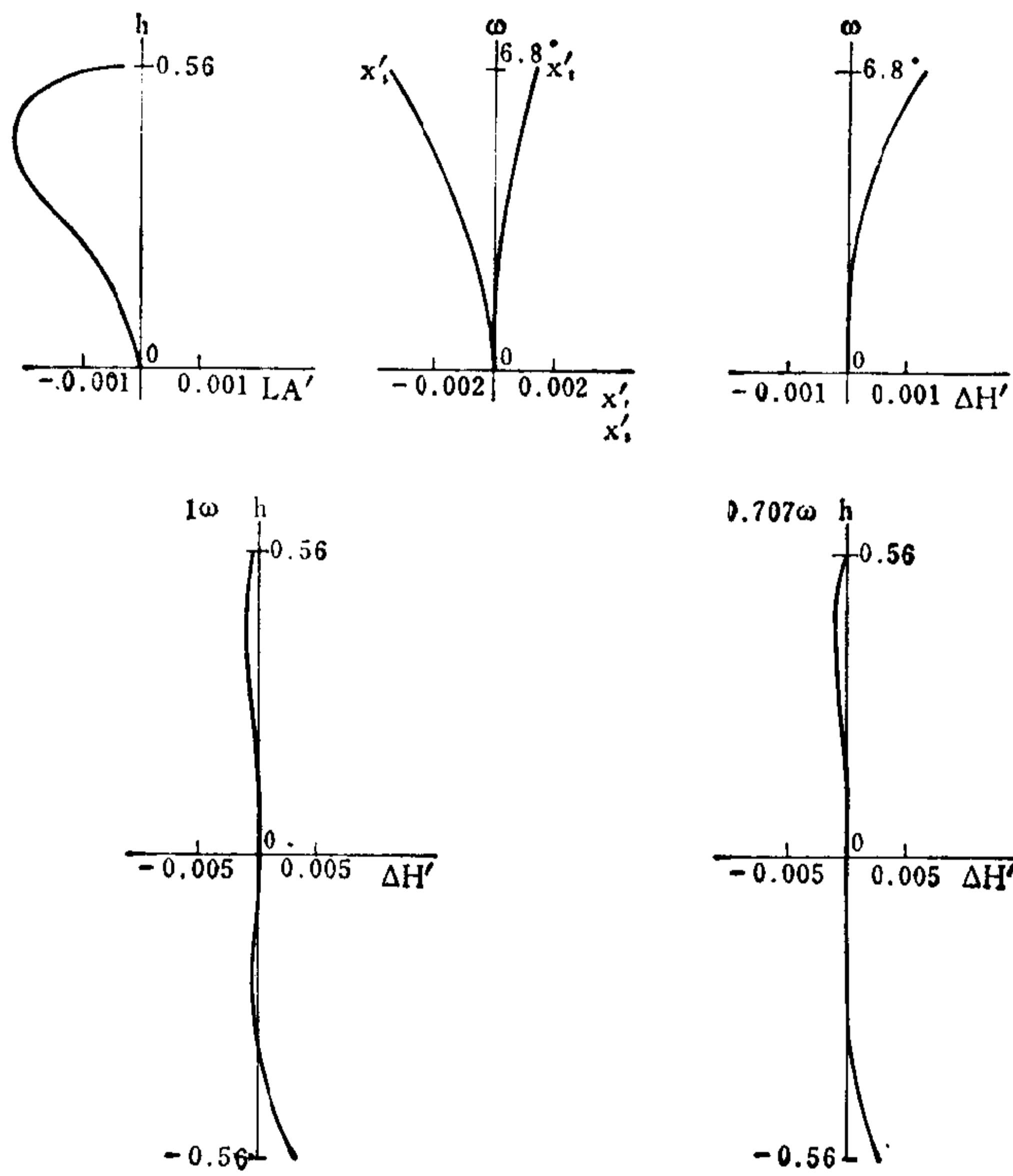

编号: 04-03-009

## 变焦距物镜

E.F.L = 12.10 ~ 36.27 B.F.L = 15.273 FNo. = 1.9 F.A. =  $\pm 14.2^\circ \sim \pm 4.7^\circ$

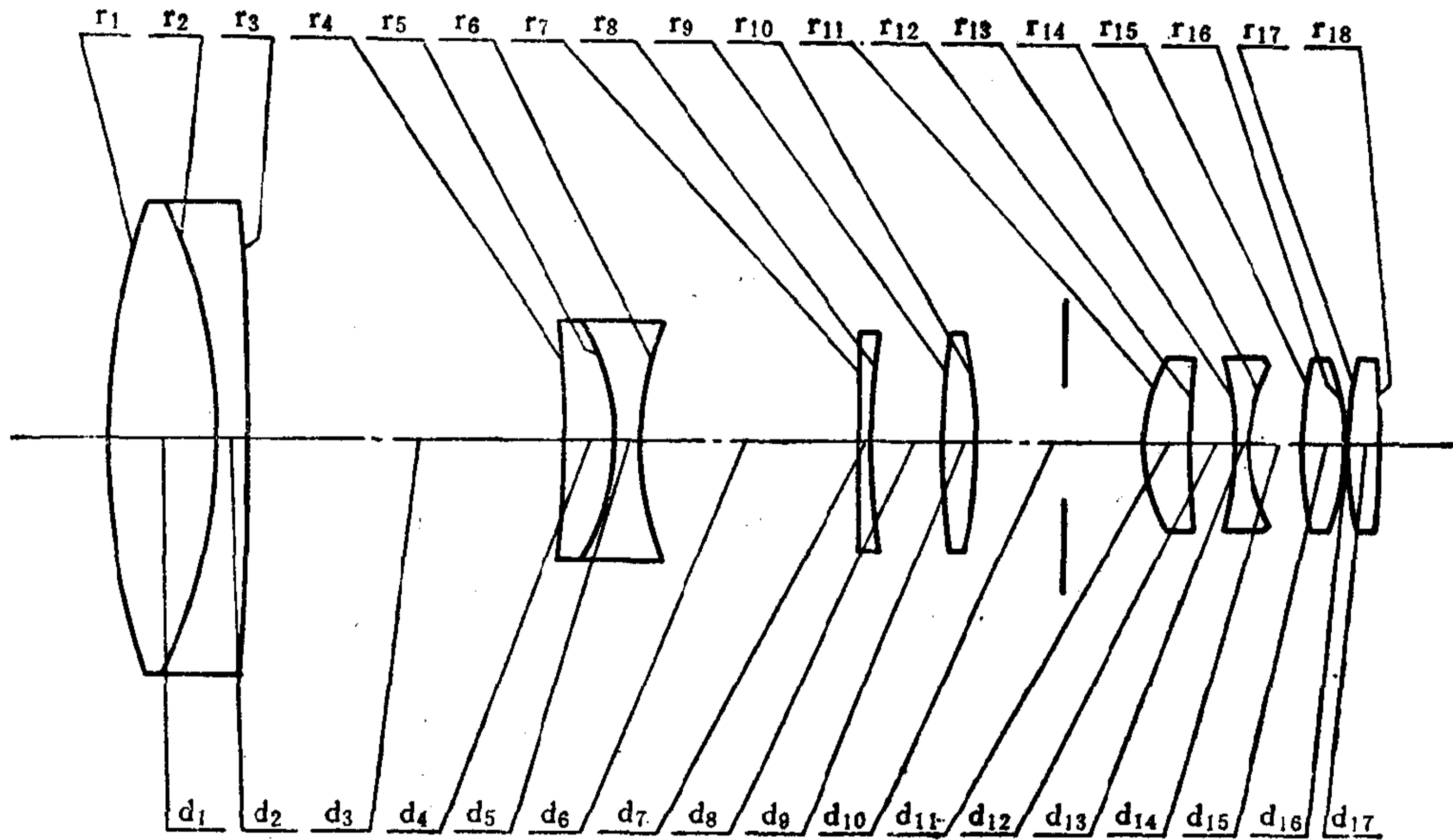

| 序号 | r        | d     | n <sub>D</sub> | v <sub>D</sub> | 序号 | r        | d      | n <sub>D</sub> | v <sub>D</sub> |
|----|----------|-------|----------------|----------------|----|----------|--------|----------------|----------------|
| 1  | 50.89    | 7.40  | 1.611          | 58.8           | 10 | - 32.96  | *** 4* |                |                |
| 2  | - 37.04  | 2.02  | 1.649          | 33.8           | 11 | 11.83    | 3.20   | 1.697          | 56.2           |
| 3  | - 390.30 | *** 1 |                |                | 12 | 203.00   | 2.94   |                |                |
| 4  | - 80.55  | 3.57  | 1.720          | 29.3           | 13 | - 22.61  | 1.06   | 1.720          | 29.3           |
| 5  | - 15.98  | 1.80  | 1.697          | 56.2           | 14 | 11.40    | 4.09   |                |                |
| 6  | 21.70    | *** 2 |                |                | 15 | 43.01    | 2.80   | 1.611          | 58.8           |
| 7  | ∞        | 1.07  | 1.649          | 33.8           | 16 | - 16.52  | 0.12   |                |                |
| 8  | 61.33    | *** 3 |                |                | 17 | 29.16    | 2.00   | 1.611          | 58.8           |
| 9  | 158.70   | 2.16  | 1.611          | 58.8           | 18 | - 137.90 |        |                |                |



04-03-009-1

|                | $\Sigma S_1$ | $\Sigma S_2$ | $\Sigma S_3$ | $\Sigma S_4$ | $\Sigma S_5$  | HI        | QP(1 $\omega$ ) |
|----------------|--------------|--------------|--------------|--------------|---------------|-----------|-----------------|
|                | -0.0534      | -0.0169      | 0.0056       | -0.0103      | -0.0526       | 3.06      | -3.4%           |
| h 或 $\omega$ % | LA'          | $\Delta H'$  | $x'_t$       | $x'_s$       | $x'_t - x'_s$ | $K'_{T1}$ | $K'_{T0.7}$     |
| 100            | -0.026       | -0.104       | 0.0909       | -0.0127      | 0.1036        | 0.2313    | 0.0119          |
| 70             | -0.128       | -0.037       | 0.0483       | -0.0077      | 0.0560        | 0.1015    | -0.0022         |

E. F. L = 12.10 ( $\pm 14.2^\circ$ )

\*\*\*1 = 2.50; \*\*\*2 = 34.56; \*\*\*3 = 2.12; \*\*\*4 = 14.58; \*\*\*4\* = 14.58 = 8.87 + 5.71

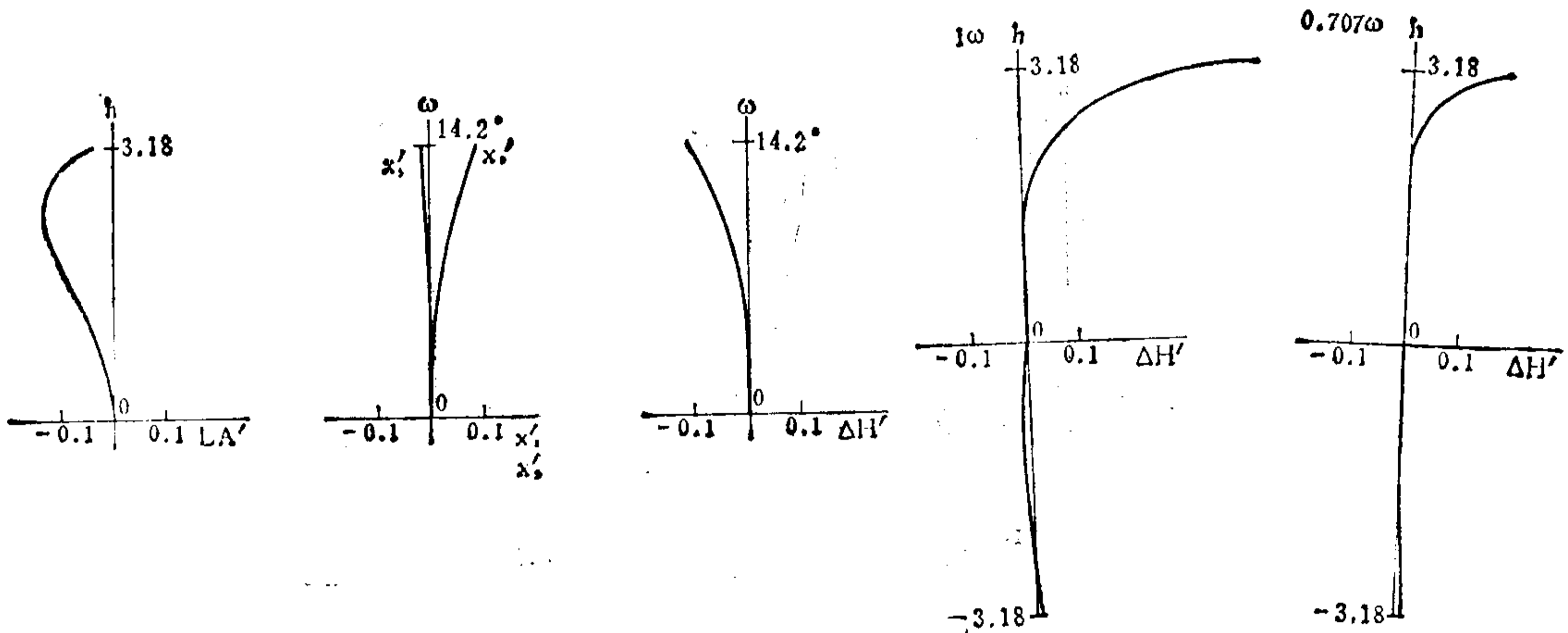

04-03-009-2

|                | $\Sigma S_1$ | $\Sigma S_2$ | $\Sigma S_3$ | $\Sigma S_4$ | $\Sigma S_5$  | HI        | QP(1 $\omega$ ) |
|----------------|--------------|--------------|--------------|--------------|---------------|-----------|-----------------|
|                | -0.0449      | -0.0110      | 0.0014       | -0.0104      | -0.0031       | 3.01      | -0.41%          |
| h 或 $\omega$ % | LA'          | $\Delta H'$  | $x'_t$       | $x'_s$       | $x'_t - x'_s$ | $K'_{T1}$ | $K'_{T0.7}$     |
| 100            | 0.041        | -0.0123      | 0.0287       | -0.0493      | 0.0780        | 0.1876    | 0.0009          |
| 70             | -0.096       | -0.0031      | -0.0102      | -0.0301      | 0.0199        | 0.0958    | -0.0035         |

E. F. L = 22.86 ( $\pm 7.5^\circ$ )

\*\*\*1 = 22.12; \*\*\*2 = 14.94; \*\*\*3 = 4.99; \*\*\*4 = 11.71; \*\*\*4\* = 11.71 = 6.00 + 5.71

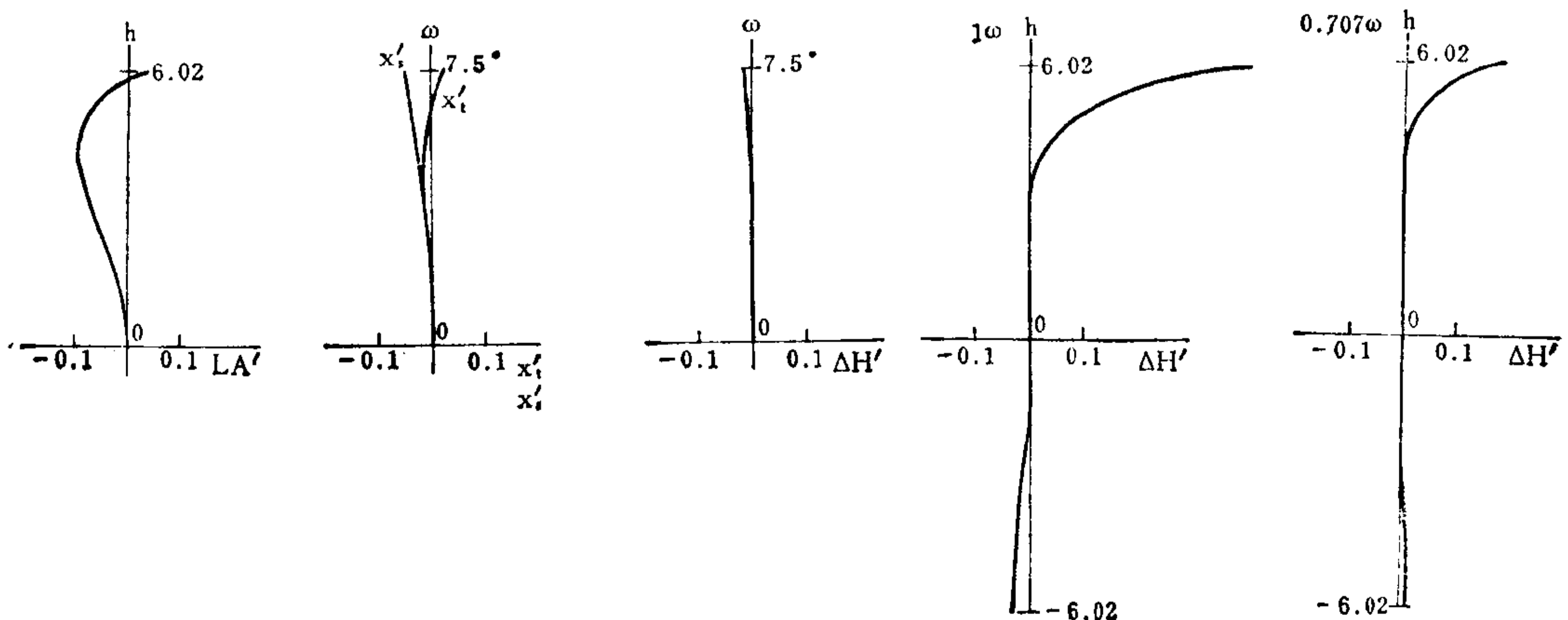

04-03-009-3

|                | $\Sigma S_1$ | $\Sigma S_2$ | $\Sigma S_3$ | $\Sigma S_4$ | $\Sigma S_5$  | HI        | QP(1 $\omega$ ) |
|----------------|--------------|--------------|--------------|--------------|---------------|-----------|-----------------|
|                | -0.0275      | -0.0003      | -0.0071      | -0.0106      | 0.0162        | 3.01      | 0.84%           |
| h 或 $\omega$ % | LA'          | $\Delta H'$  | $x'_t$       | $x'_s$       | $x'_t - x'_s$ | $K'_{T1}$ | $K'_{T0.7}$     |
| 100            | 0.173        | 0.0254       | -0.1149      | -0.1044      | -0.0105       | 0.1625    | 0.0064          |
| 70             | -0.031       | 0.0099       | -0.0925      | -0.0590      | -0.0335       | 0.1196    | 0.0120          |

E. F. L = 36.27 ( $\pm 4.7^\circ$ )

\*\*\*1 = 31.86; \*\*\*2 = 5.20; \*\*\*3 = 2.87; \*\*\*4 = 13.83; \*\*\*4' = 13.83 = 8.12 + 5.71

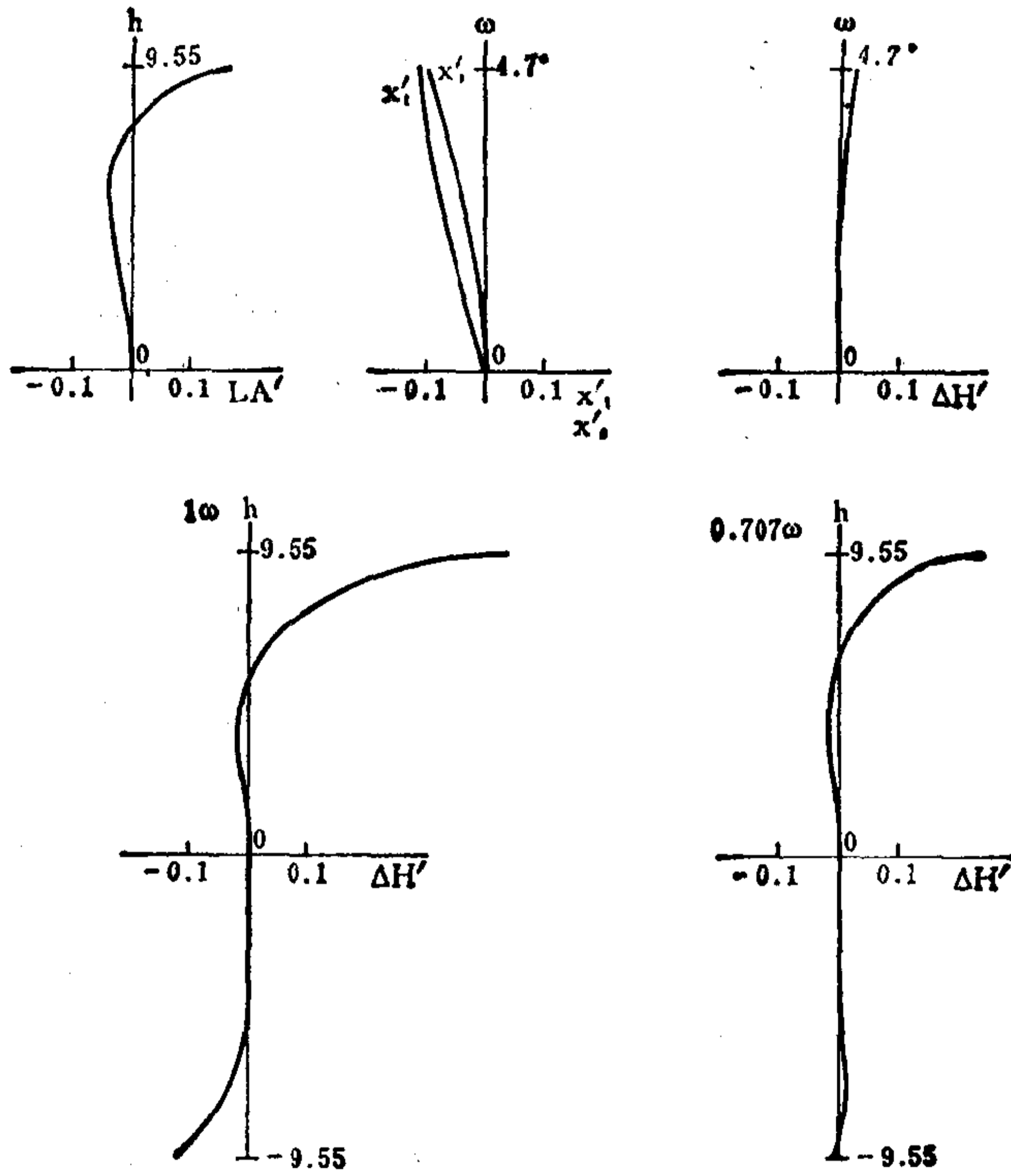

编号: 04-03-010

# 变 焦 距 物 镜

E.F.L = 35.50 ~ 202.60 B.F.L = 45.4 FNo. = 1.8 F.A. = ± 13.2° ~ ± 2.3°

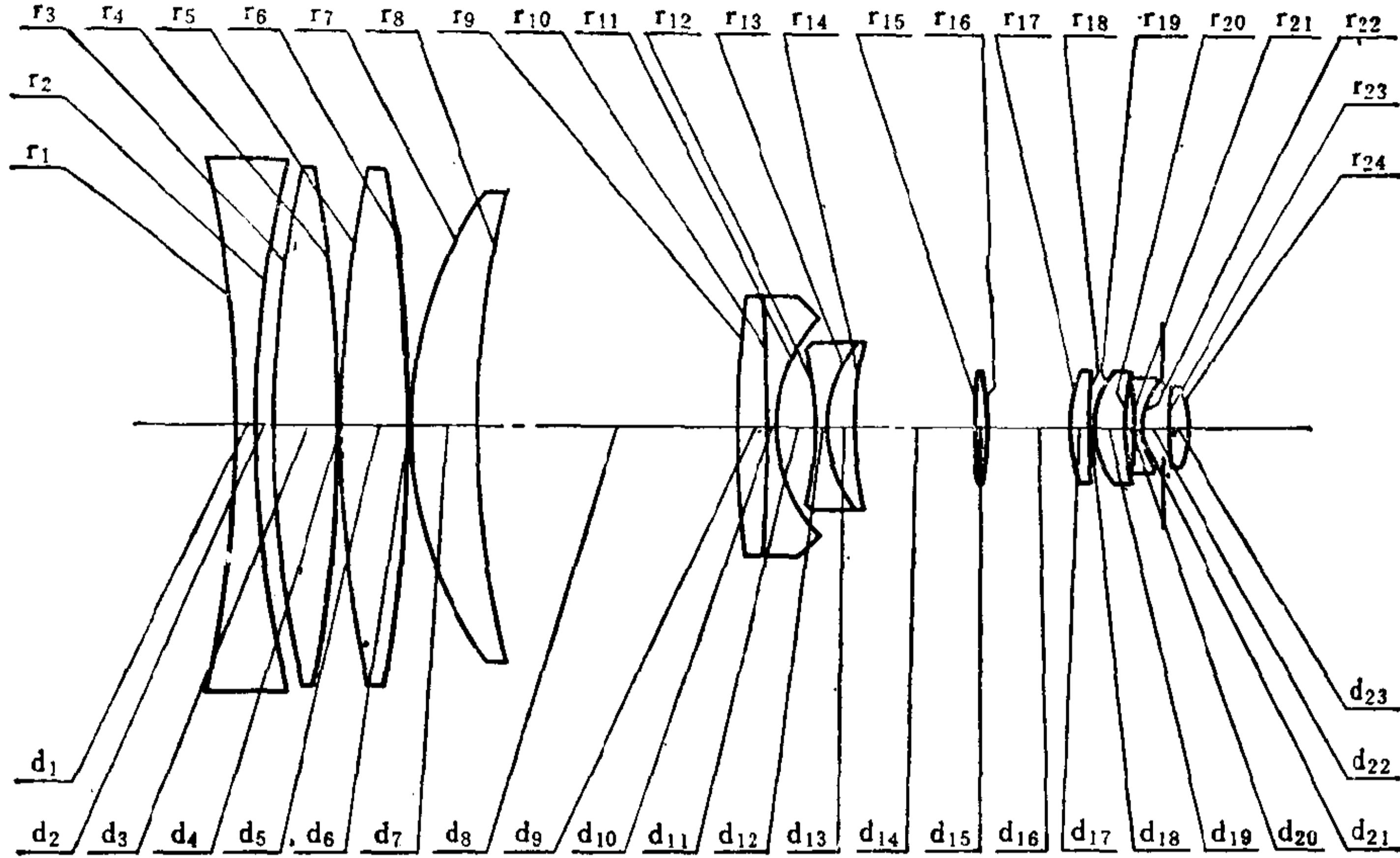

| 序号 | r        | d     | n <sub>d</sub> | v <sub>d</sub> | 序号 | r       | d      | n <sub>d</sub> | v <sub>d</sub> |
|----|----------|-------|----------------|----------------|----|---------|--------|----------------|----------------|
| 1  | -552.80  | 8.50  | 1.74080        | 28.05          | 13 | 57.00   | 12.50  | 1.80518        | 25.46          |
| 2  | 468.80   | 8.50  |                |                | 14 | 156.05  | *** 3  |                |                |
| 3  | 627.10   | 27.50 | 1.62041        | 60.29          | 15 | 349.40  | 5.00   | 1.65830        | 57.29          |
| 4  | -627.10  | 0.50  |                |                | 16 | -173.40 | 35.00  |                |                |
| 5  | 627.10   | 27.50 | 1.62041        | 60.29          | 17 | 59.95   | 9.00   | 1.59181        | 58.25          |
| 6  | -627.10  | 0.50  |                |                | 18 | 901.75  | 0.50   |                |                |
| 7  | 171.55   | 30.00 | 1.62041        | 60.29          | 19 | 37.25   | 13.00  | 1.71300        | 53.89          |
| 8  | 415.40   | *** 1 |                |                | 20 | 86.90   | 2.00   |                |                |
| 9  | 944.50   | 12.50 | 1.80518        | 25.46          | 21 | -475.00 | 5.00   | 1.80518        | 25.46          |
| 10 | -1832.50 | 5.00  | 1.51821        | 65.18          | 22 | 28.70   | 11.55* |                |                |
| 11 | 67.15    | *** 2 |                |                | 23 | 121.00  | 8.35   | 1.62280        | 56.88          |
| 12 | -137.95  | 5.00  | 1.71300        | 53.89          | 24 | -48.05  |        |                |                |

11.55\* = 6.00 + 5.55

04-03-010-1

|                | $\Sigma S_1$ | $\Sigma S_2$ | $\Sigma S_3$ | $\Sigma S_4$ | $\Sigma S_5$  | HI        | QP(1 $\omega$ ) |
|----------------|--------------|--------------|--------------|--------------|---------------|-----------|-----------------|
|                | -0.1357      | -0.0131      | 0.0134       | -0.0119      | -0.0521       | 8.31      | -1.08%          |
| h 或 $\omega$ % | LA'          | $\Delta H'$  | $x'_t$       | $x'_s$       | $x'_t - x'_s$ | $K'_{T1}$ | $K'_{T0.7}$     |
| 100            | -0.073       | -0.0905      | 0.1532       | 0.0077       | 0.1455        | 0.0811    | -0.0086         |
| 70             | -0.312       | -0.0329      | 0.0787       | 0.0017       | 0.0770        | 0.0539    | -0.0074         |

E. F. L = 35.50 ( $\pm 13.2^\circ$ )

\*\*\*1=5.10, \*\*\*2=95.30, \*\*\*3=77.10

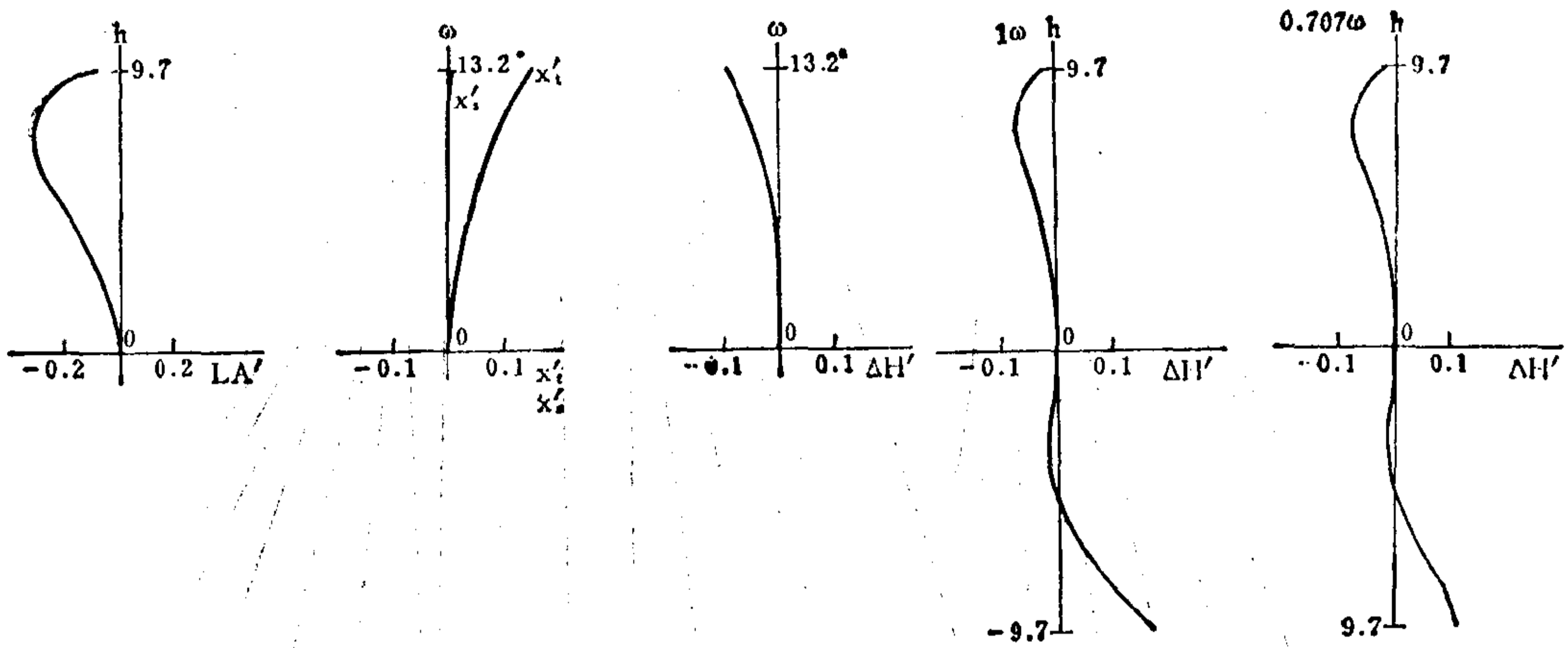

04-03-010-2

|                | $\Sigma S_1$ | $\Sigma S_2$ | $\Sigma S_3$ | $\Sigma S_4$ | $\Sigma S_5$  | HI        | QP(1 $\omega$ ) |
|----------------|--------------|--------------|--------------|--------------|---------------|-----------|-----------------|
|                | -0.1111      | -0.0058      | -0.0023      | -0.0120      | 0.0117        | 8.12      | 0.21%           |
| h 或 $\omega$ % | LA'          | $\Delta H'$  | $x'_t$       | $x'_s$       | $x'_t - x'_s$ | $K'_{T1}$ | $K'_{T0.7}$     |
| 100            | 0.100        | 0.0173       | -0.0793      | -0.0812      | 0.0019        | 0.1810    | 0.0292          |
| 70             | -0.226       | 0.0068       | -0.0521      | -0.0444      | -0.0077       | 0.1185    | 0.0189          |

E. F. L = 101.00 ( $\pm 4.6^\circ$ )

\*\*\*1=111.40, \*\*\*2=15.30, \*\*\*3=50.80

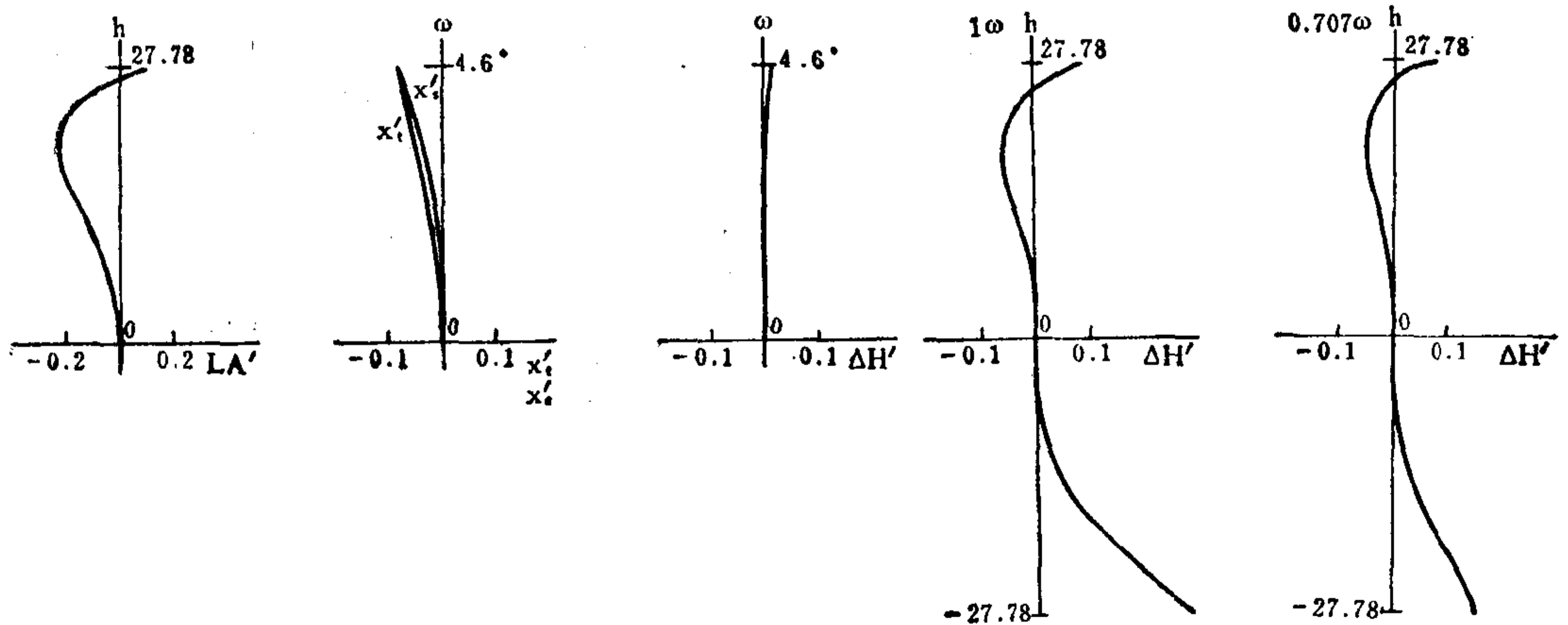

04-03-010-3

|                | $\Sigma S_1$ | $\Sigma S_2$ | $\Sigma S_3$ | $\Sigma S_4$ | $\Sigma S_5$  | HI        | QP(1 $\omega$ ) |
|----------------|--------------|--------------|--------------|--------------|---------------|-----------|-----------------|
|                | -0.1222      | 0.0399       | -0.0275      | -0.0120      | 0.0487        | 8.1       | 1.02%           |
| h 或 $\omega$ % | LA'          | $\Delta H'$  | $x'_t$       | $x'_s$       | $x'_t - x'_s$ | $K'_{T1}$ | $K'_{T0.7}$     |
| 100            | -0.070       | 0.0823       | -0.484       | -0.231       | -0.253        | 0.3620    | 0.1186          |
| 70             | -0.277       | 0.0301       | -0.278       | -0.123       | -0.155        | 0.2805    | 0.0963          |

E. F. L = 202.60 ( $\pm 2.3^\circ$ )

\*\*\*1 = 145.60; \*\*\*2 = 28.50; \*\*\*3 = 3.40

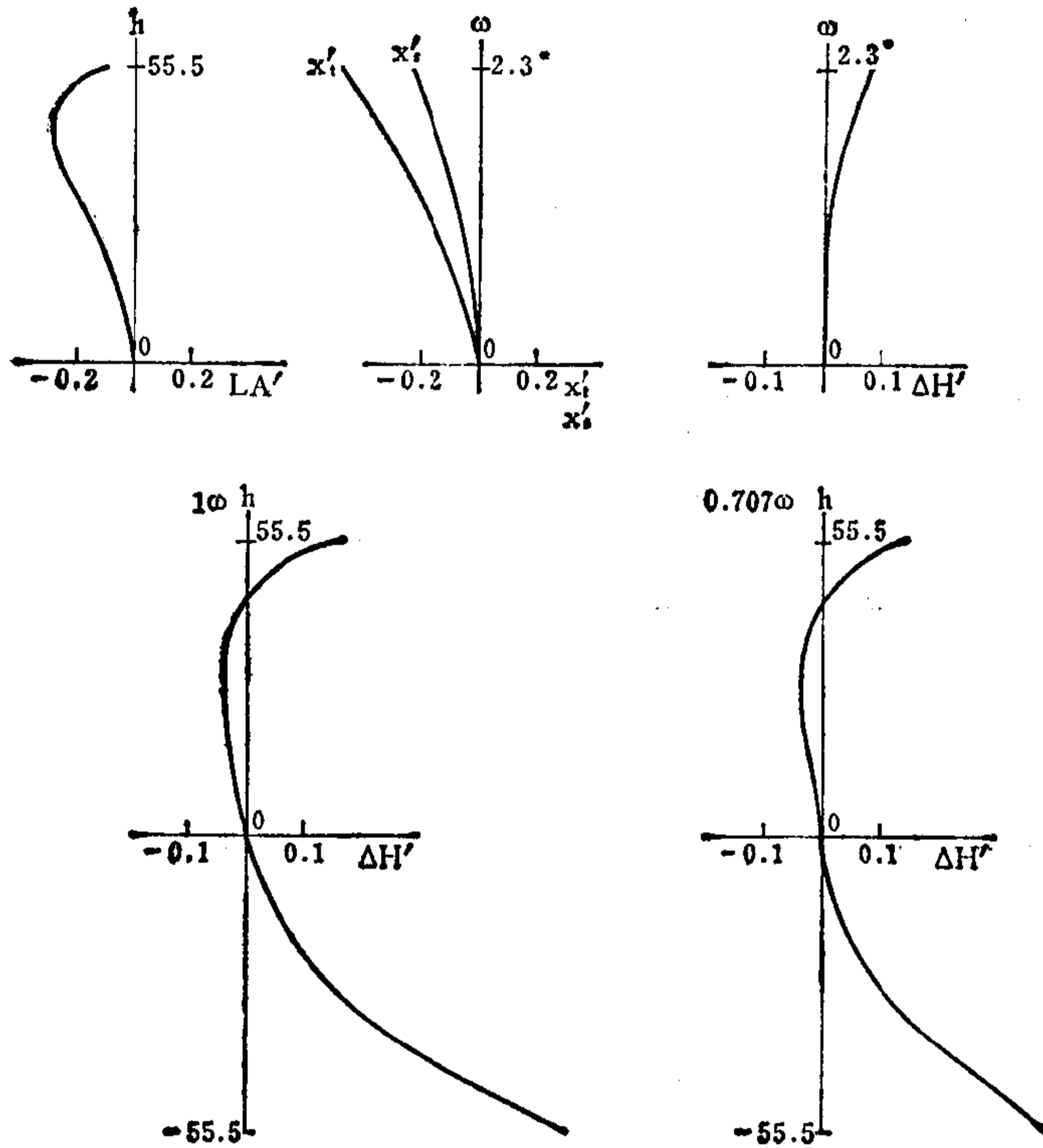

编号: 04-03-011

## 用于近距离摄影的变焦距镜头

E.F.L=7.50~56.30 B.F.L=14.22 FNo.=1.8 F.A.=±26.70°~±3.55°

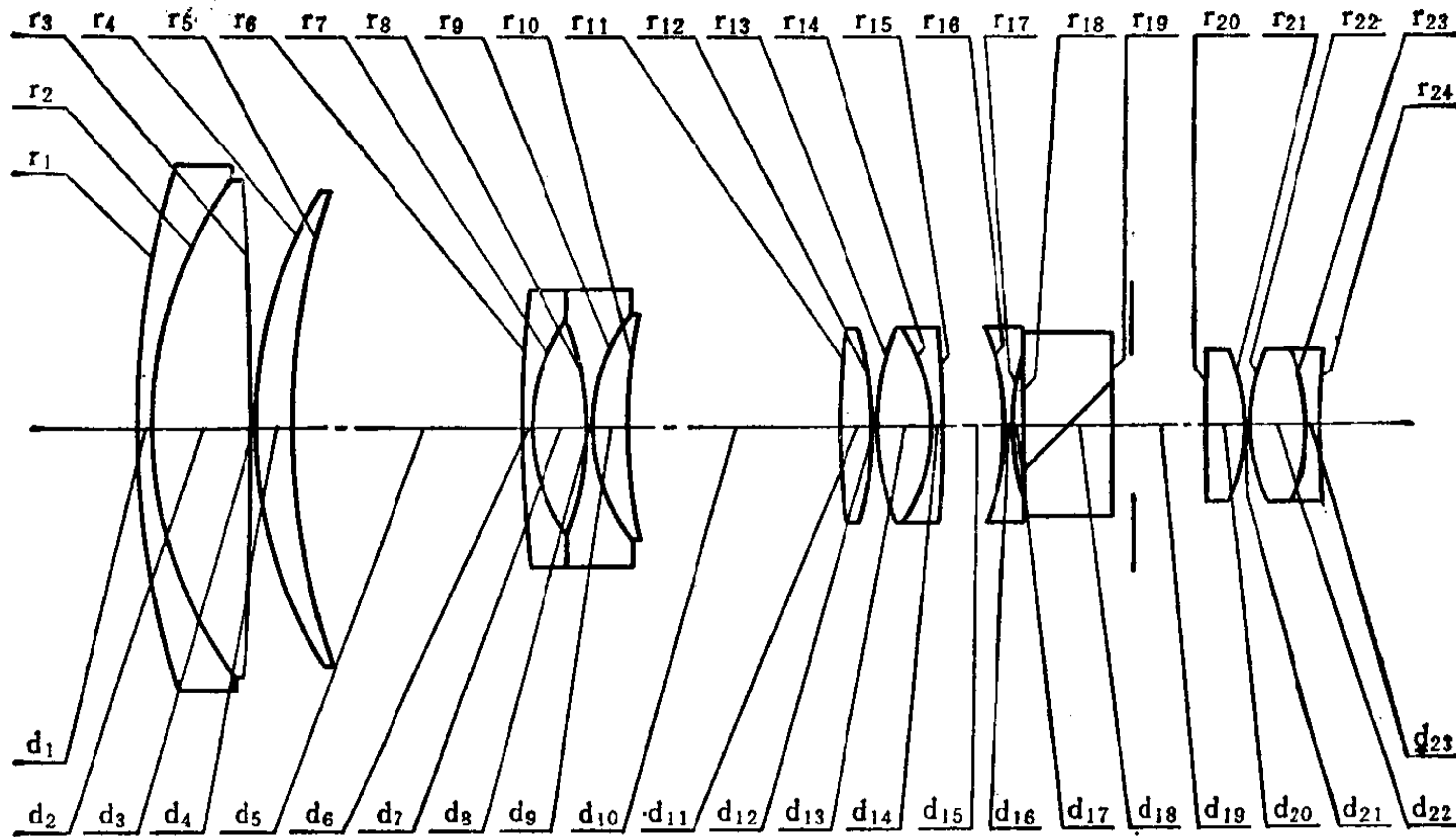

| 序号 | r        | d     | n <sub>d</sub> | v    | 序号 | r        | d     | n <sub>d</sub> | v    |
|----|----------|-------|----------------|------|----|----------|-------|----------------|------|
| 1  | 85.943   | 1.40  | 1.74077        | 27.7 | 13 | 25.000   | 5.50  | 1.65830        | 57.3 |
| 2  | 40.600   | 9.50  | 1.65160        | 58.5 | 14 | -17.200  | 0.90  | 1.72342        | 38.0 |
| 3  | -292.560 | 0.10  |                |      | 15 | -254.650 | *** 3 |                |      |
| 4  | 42.962   | 3.40  | 1.5168         | 64.2 | 16 | -24.050  | 0.80  | 1.65830        | 57.3 |
| 5  | 69.590   | *** 1 |                |      | 17 | 24.050   | 0.85  |                |      |
| 6  | 205.150  | 0.90  | 1.717          | 47.9 | 18 | ∞        | 8.30  | 1.57501        | 41.3 |
| 7  | 17.200   | 5.00  |                |      | 19 | ∞        | 8.90* |                |      |
| 8  | -28.400  | 0.80  | 1.51835        | 60.3 | 20 | 1100.000 | 3.90  | 1.62374        | 47.0 |
| 9  | 17.558   | 3.30  | 1.72825        | 28.3 | 21 | -17.335  | 0.20  |                |      |
| 10 | 52.125   | *** 2 |                |      | 22 | 17.900   | 5.30  | 1.62041        | 60.3 |
| 11 | 86.894   | 2.90  | 1.6516         | 58.3 | 23 | -14.530  | 1.20  | 1.80518        | 25.5 |
| 12 | -33.490  | 0.10  |                |      | 24 | 174.600  |       |                |      |

8.90\* = 2.90 + 6.00

04-03-011-1

|                | $\Sigma S_1$ | $\Sigma S_2$ | $\Sigma S_3$ | $\Sigma S_4$ | $\Sigma S_5$  | HI        | QP(1 $\omega$ ) |
|----------------|--------------|--------------|--------------|--------------|---------------|-----------|-----------------|
|                | -0.00005     | -0.00450     | 0.00707      | -0.00636     | -0.08159      | 3.77      | -2.99%          |
| h 或 $\omega$ % | LA'          | $\Delta H'$  | $x'_t$       | $x'_s$       | $x'_t - x'_s$ | $K'_{T1}$ | $K'_{T0.7}$     |
| 100            | -0.0141      | -0.1127      | -0.2263      | -0.0538      | -0.1725       | 0.00862   | 0.00206         |
| 70             | -0.0008      | -0.0497      | -0.0306      | -0.0159      | -0.0147       | -0.00112  | -0.00378        |

E. F. L = 7.50 ( $\pm 26.7^\circ$ )

\*\*\*1 = 1.73, \*\*\*2 = 45.72, \*\*\*3 = 1.47

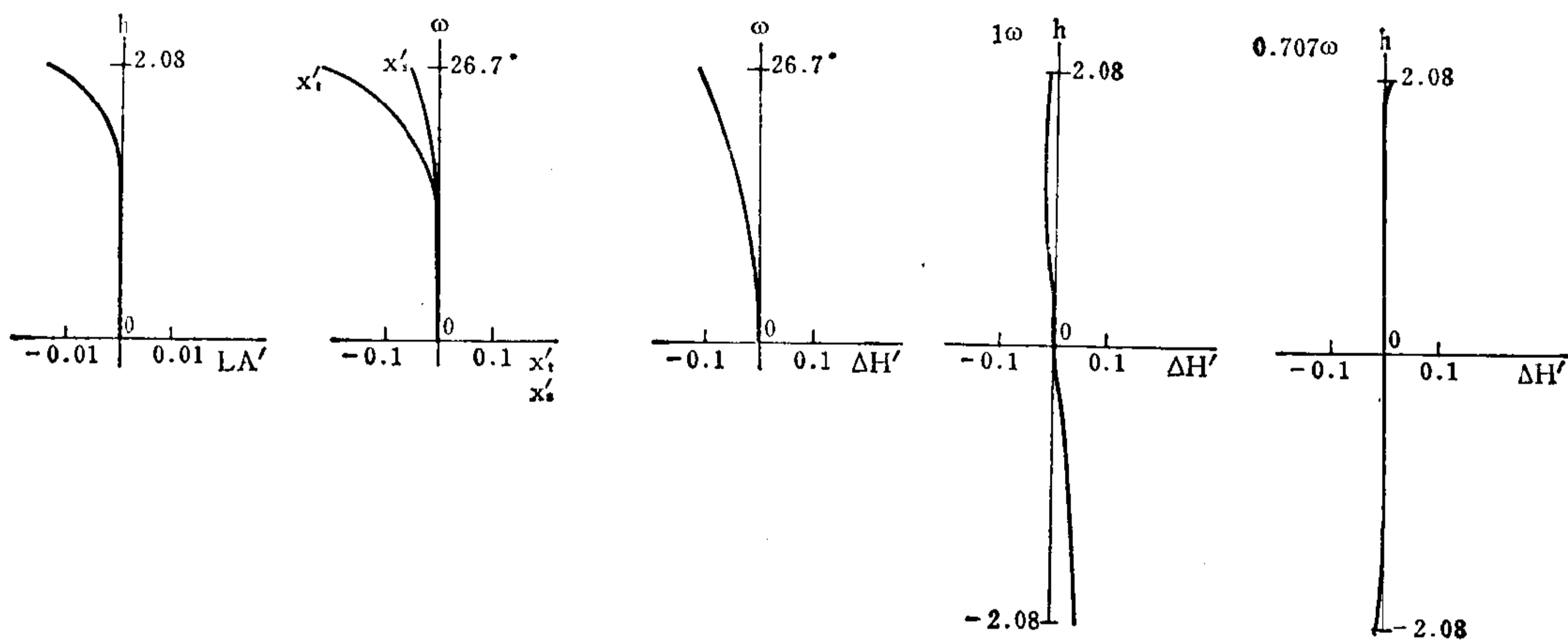

04-03-011-2

|                | $\Sigma S_1$ | $\Sigma S_2$ | $\Sigma S_3$ | $\Sigma S_4$ | $\Sigma S_5$  | HI        | QP(1 $\omega$ ) |
|----------------|--------------|--------------|--------------|--------------|---------------|-----------|-----------------|
|                | -0.01142     | 0.00083      | 0.00401      | -0.00683     | 0.03673       | 3.53      | 3.04%           |
| h 或 $\omega$ % | LA'          | $\Delta H'$  | $x'_t$       | $x'_s$       | $x'_t - x'_s$ | $K'_{T1}$ | $K'_{T0.7}$     |
| 100            | -0.0259      | 0.1072       | -0.1437      | -0.0372      | -0.1065       | -0.0978   | -0.0231         |
| 70             | -0.0243      | 0.0301       | -0.0195      | -0.0136      | -0.0059       | -0.0538   | -0.0137         |

E. F. L = 21.90 ( $\pm 9.2^\circ$ )

\*\*\*1 = 22.43, \*\*\*2 = 20.37, \*\*\*3 = 6.12

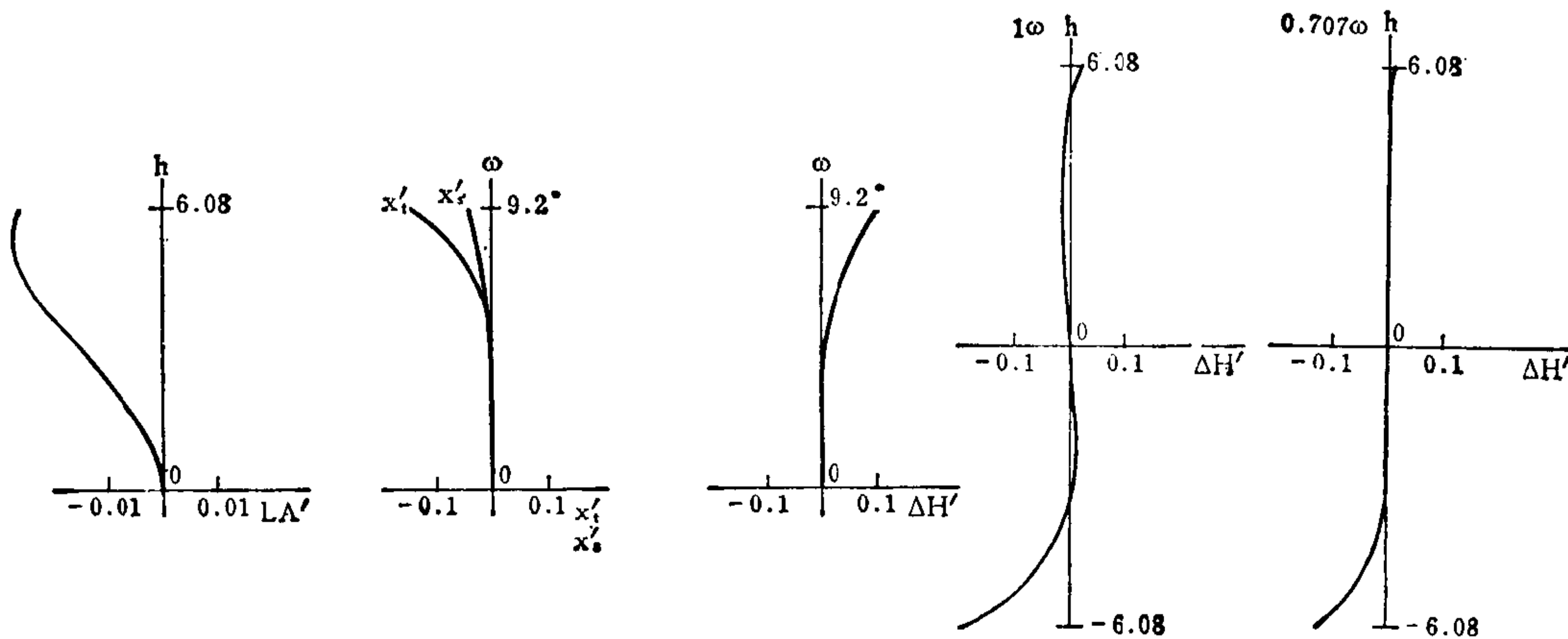



04-03-011-3

|                | $\Sigma S_1$ | $\Sigma S_2$ | $\Sigma S_3$ | $\Sigma S_4$ | $\Sigma S_5$  | HI        | QP(1 $\omega$ ) |
|----------------|--------------|--------------|--------------|--------------|---------------|-----------|-----------------|
|                | -0.00558     | 0.00607      | -0.00374     | -0.00683     | 0.05126       | 3.5       | 3.25%           |
| h 或 $\omega$ % | LA'          | $\Delta H'$  | $x'_t$       | $x'_s$       | $x'_t - x'_s$ | $K'_{T1}$ | $K'_{T0.7}$     |
| 100            | 0.0169       | 0.1138       | -0.1692      | -0.0667      | -0.1025       | -8.1295   | -0.3093         |
| 70             | -0.0077      | 0.0357       | -0.0750      | -0.0335      | -0.0415       | -0.4015   | -0.0333         |

E. F. L = 56.30 ( $\pm 3.55^\circ$ )

\*\*\* 1 = 33.23, \*\*\* 2 = 2.96, \*\*\* 3 = 12.73

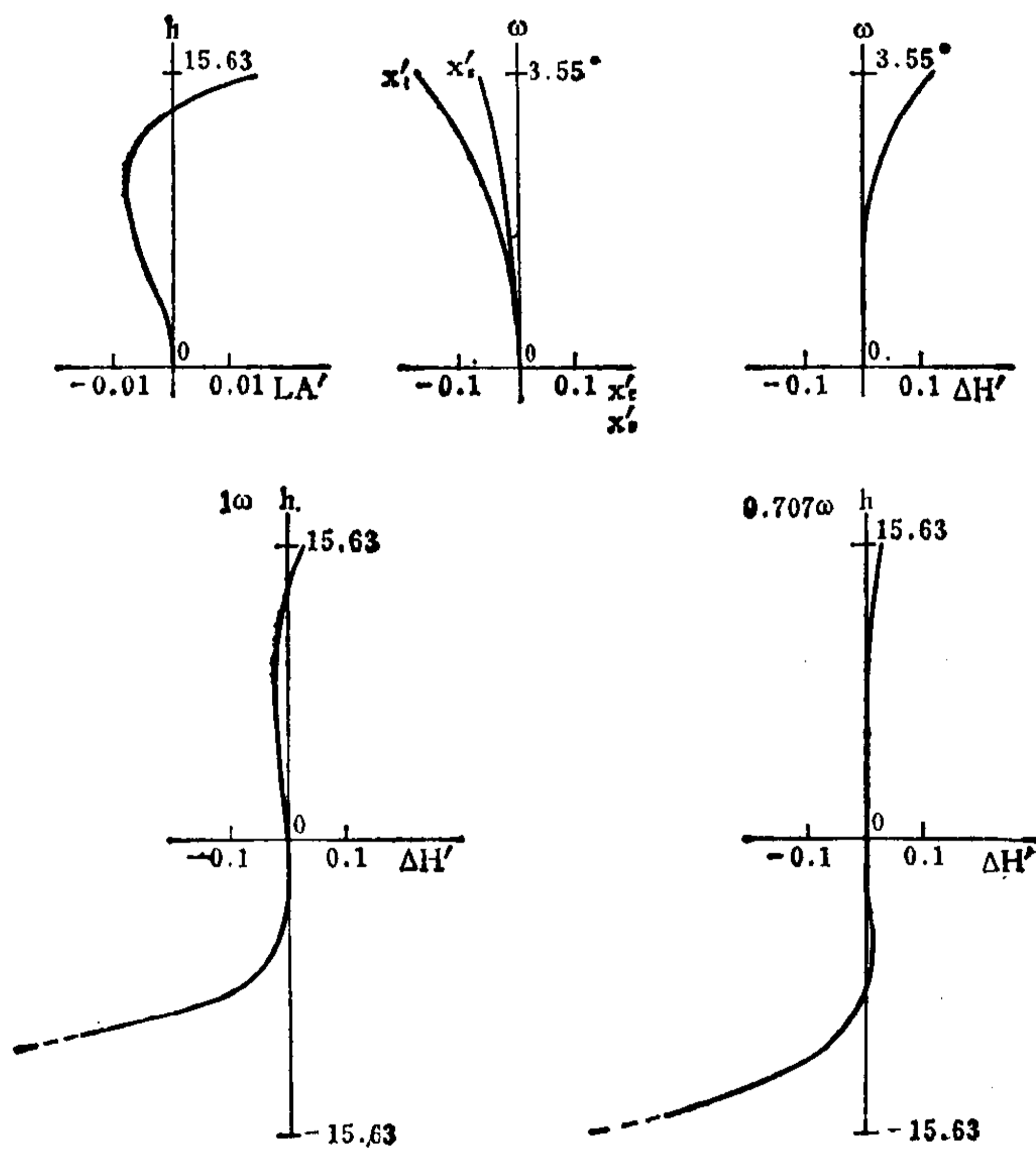

编号: 04-03-012

# 变 焦 距 镜 头

E.F.L=10.0~40.0 B.F.L=13.46 FNo.=1.4 F.A.=±17.5°~±4.3°

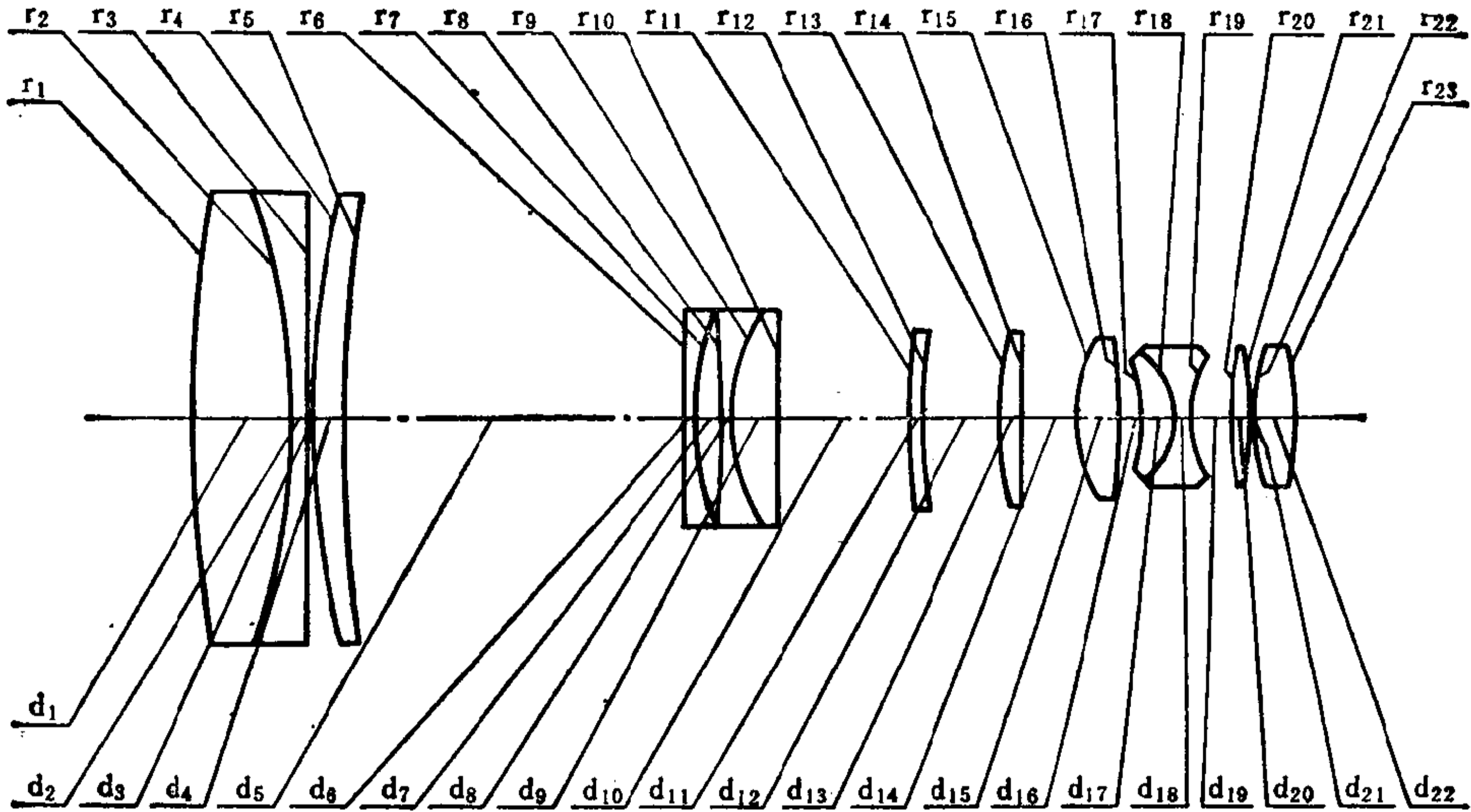

| 序号 | r        | d      | n <sub>d</sub> | v    | 序号 | r       | d       | n <sub>d</sub> | v    |
|----|----------|--------|----------------|------|----|---------|---------|----------------|------|
| 1  | 187.000  | 9.0000 | 1.6779         | 55.5 | 13 | 35.130  | 2.0000  | 1.6385         | 55.5 |
| 2  | -64.000  | 1.5000 | 1.6889         | 31.1 | 14 | ∞       | 5.0000  |                |      |
| 3  | ∞        | 0.5000 |                |      | 15 | 13.800  | 4.2700  | 1.6073         | 56.7 |
| 4  | 81.270   | 3.0000 | 1.6237         | 47.0 | 16 | -60.000 | 2.1300  |                |      |
| 5  | 321.440  | *** 1  |                |      | 17 | -16.750 | 3.0000  | 1.7200         | 50.3 |
| 6  | 1016.400 | 1.0000 | 1.6910         | 54.8 | 18 | -7.940  | 1.5800  | 1.6483         | 33.8 |
| 7  | 30.330   | 2.2863 |                |      | 19 | 11.229  | 3.7300* |                |      |
| 8  | -107.400 | 1.0000 | 1.6910         | 54.8 | 20 | 33.400  | 2.0000  | 1.6204         | 60.3 |
| 9  | 18.500   | 4.5000 | 1.6727         | 32.2 | 21 | -33.400 | 0.1600  |                |      |
| 10 | ∞        | *** 2  |                |      | 22 | 21.000  | 4.0000  | 1.6204         | 60.3 |
| 11 | 180.900  | 1.0000 | 1.6385         | 55.5 | 23 | -30.720 |         |                |      |
| 12 | 50.000   | *** 3  |                |      |    |         |         |                |      |

3.7300\* = 2.0000 + 1.7300

04-03-012-1

|                | $\Sigma S_1$ | $\Sigma S_2$ | $\Sigma S_3$ | $\Sigma S_4$ | $\Sigma S_5$  | HI        | QP(1 $\omega$ ) |
|----------------|--------------|--------------|--------------|--------------|---------------|-----------|-----------------|
|                | -0.06519     | 0.00972      | 0.00775      | -0.02808     | -0.06737      | 3.17      | -3.32%          |
| h 或 $\omega$ % | LA'          | $\Delta H'$  | $x'_t$       | $x'_s$       | $x'_t - x'_s$ | $K'_{T1}$ | $K'_{T0.7}$     |
| 100            | -0.151       | -0.105       | -0.0150      | -0.0750      | 0.0600        | -5.4047   | -0.0266         |
| 70             | -0.038       | -0.036       | -0.0087      | -0.0395      | 0.0308        | 1.5200    | -0.0152         |

E. F. L = 10.0 ( $\pm 17.5^\circ$ )

\*\*\*1 = 3.7757; \*\*\*2 = 52.2675; \*\*\*3 = 1.0000

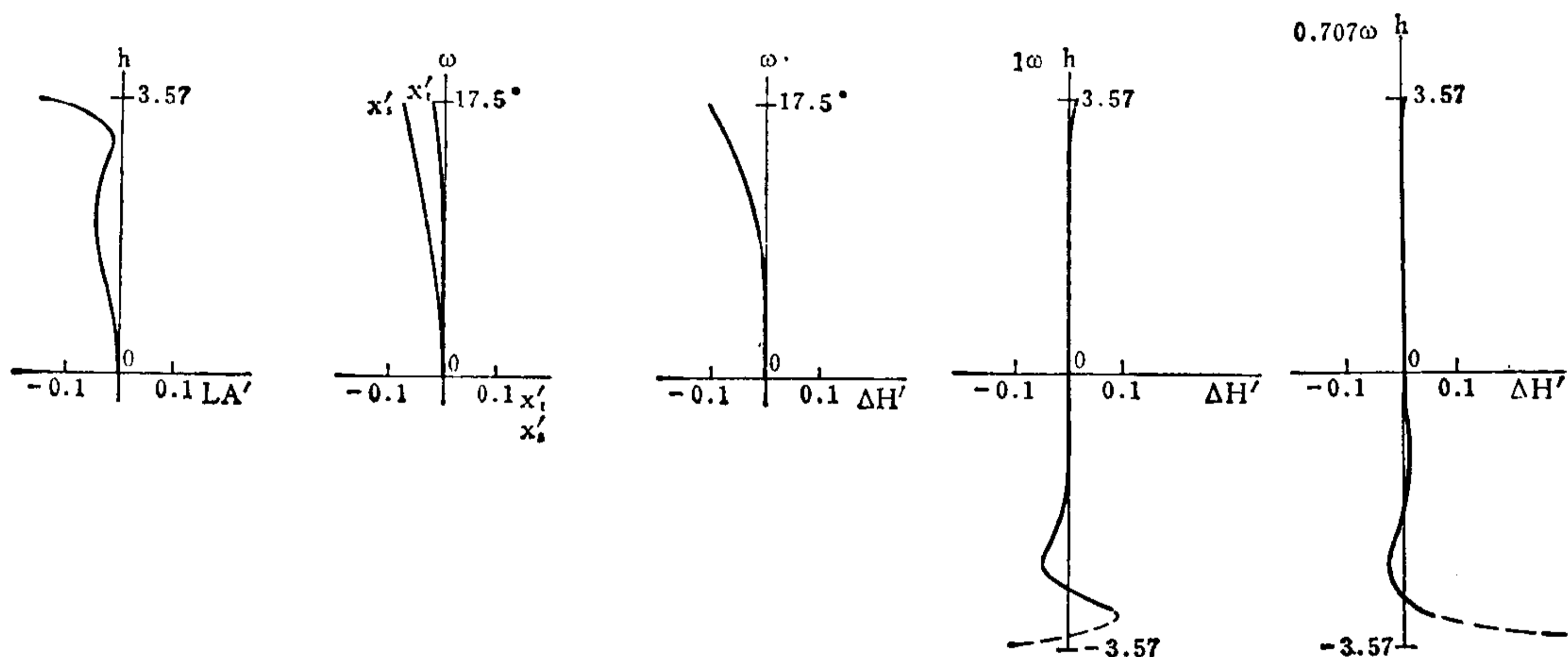

04-03-012-2

|                | $\Sigma S_1$ | $\Sigma S_2$ | $\Sigma S_3$ | $\Sigma S_4$ | $\Sigma S_5$  | HI        | QP(1 $\omega$ ) |
|----------------|--------------|--------------|--------------|--------------|---------------|-----------|-----------------|
|                | -0.06911     | 0.01279      | 0.00421      | -0.02778     | 0.00038       | 3.03      | -0.07%          |
| h 或 $\omega$ % | LA'          | $\Delta H'$  | $x'_t$       | $x'_s$       | $x'_t - x'_s$ | $K'_{T1}$ | $K'_{T0.7}$     |
| 100            | -0.180       | -0.0021      | -0.0388      | -0.0808      | 0.0420        | -5.4703   | -0.0297         |
| 70             | -0.045       | -0.0004      | -0.0204      | -0.0422      | 0.0218        | 2.3589    | -0.0178         |

E. F. L = 22.4 ( $\pm 7.7^\circ$ )

\*\*\*1 = 37.1090; \*\*\*2 = 12.4510; \*\*\*3 = 7.4832

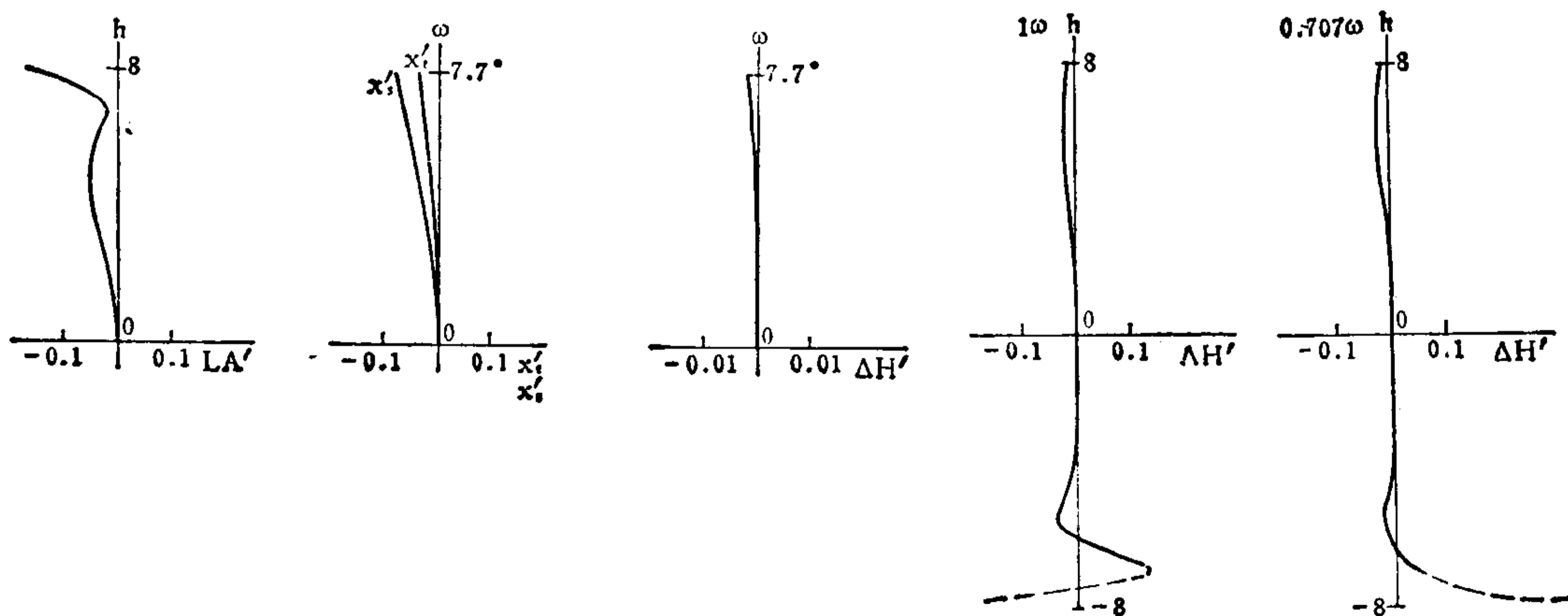

04-03-012-3

|                | $\Sigma S_1$ | $\Sigma S_2$ | $\Sigma S_3$ | $\Sigma S_4$ | $\Sigma S_5$  | HI        | QP(1 $\omega$ ) |
|----------------|--------------|--------------|--------------|--------------|---------------|-----------|-----------------|
|                | -0.04018     | 0.01623      | 0.00335      | -0.02844     | 0.00618       | 3.04      | 0.21%           |
| h 或 $\omega$ % | LA'          | $\Delta H'$  | $x'_t$       | $x'_s$       | $x'_t - x'_s$ | $K'_{T1}$ | $K'_{T0.7}$     |
| 100            | -0.040       | 0.0063       | -0.0515      | -0.0870      | 0.0355        | -5.5309   | -0.0198         |
| 70             | 0.013        | 0.0025       | -0.0284      | -0.0456      | 0.0172        | -4.7343   | -0.0089         |

E. F. L = 40.0 ( $\pm 4.3^\circ$ )

\*\*\*1 = 53.7757; \*\*\*2 = 2.2675; \*\*\*3 = 1.0000

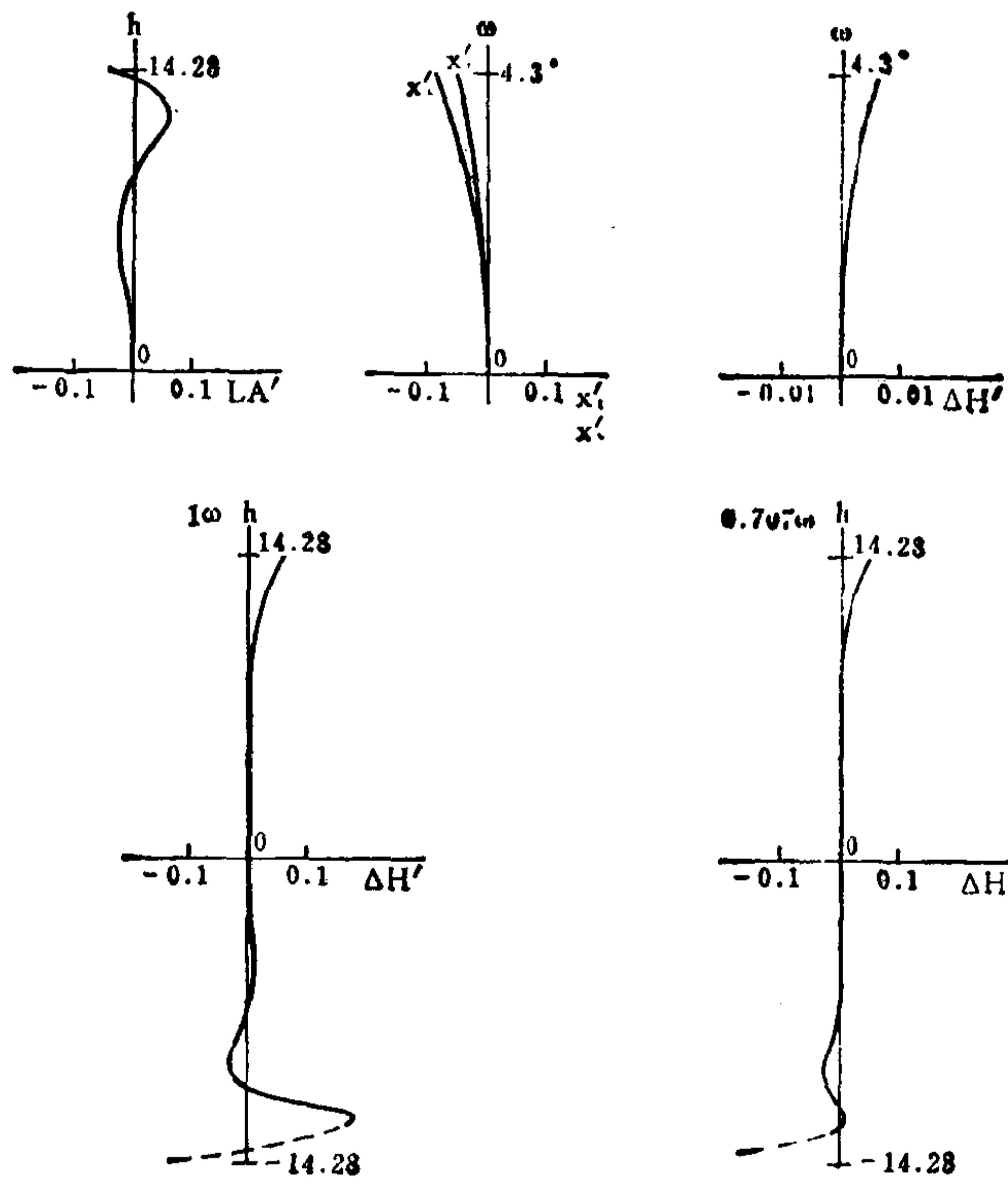

编号: 04-03-013

# 变 焦 距 物 镜

E.F.L.=50~200    B.F.L.=58.1    FNo.=1.8    F.A.=±9.1'~±2.8'

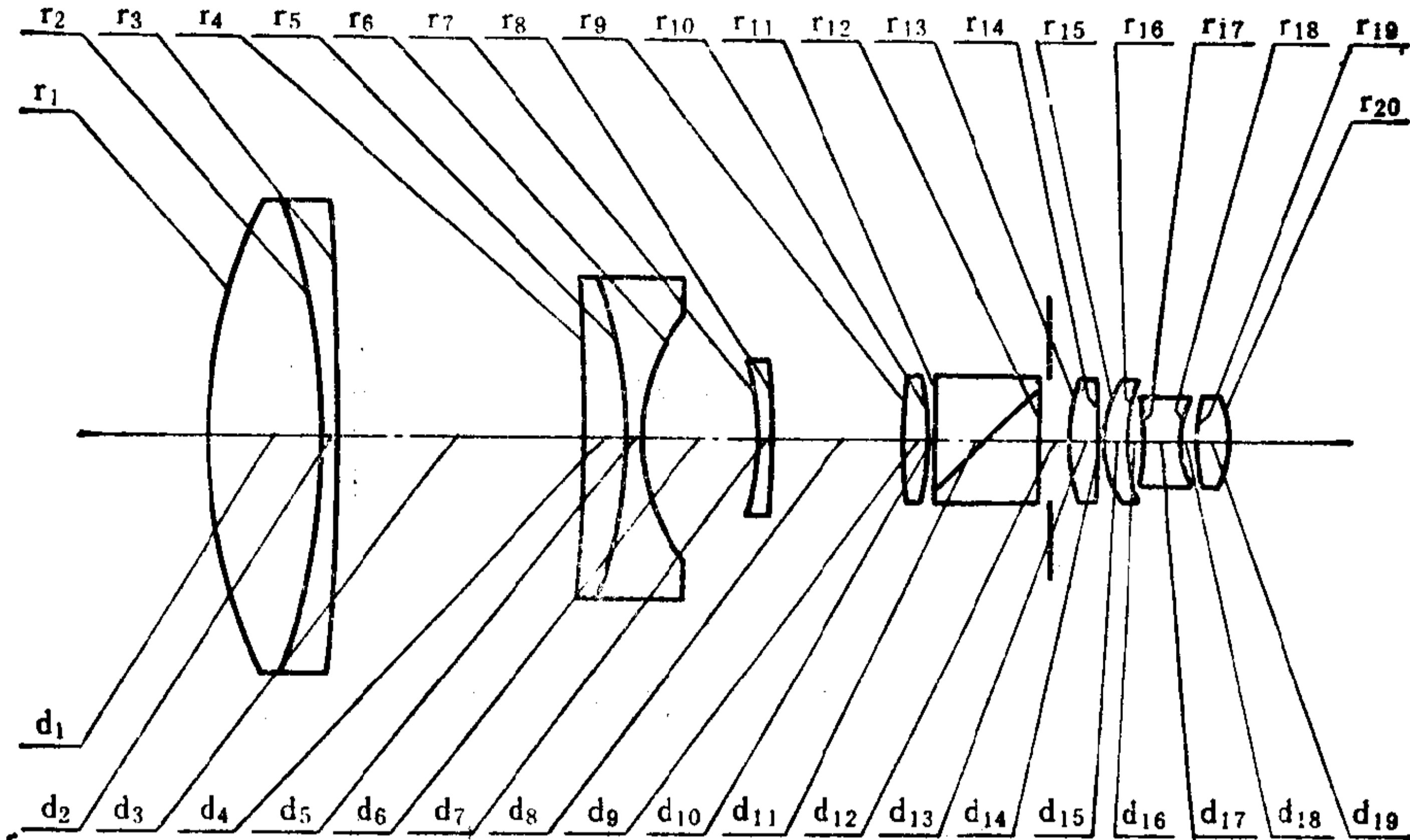

| 序号 | r        | d     | n <sub>d</sub> | v <sub>d</sub> | 序号 | r       | d      | n <sub>d</sub> | v <sub>d</sub> |
|----|----------|-------|----------------|----------------|----|---------|--------|----------------|----------------|
| 1  | 275.13   | 58.75 | 1.61772        | 49.78          | 11 | ∞       | 55.00  | 1.52015        | 63.59          |
| 2  | -355.69  | 8.75  | 1.76180        | 26.98          | 12 | ∞       | 15.63* |                |                |
| 3  | -3212.50 | *** 1 |                |                | 13 | 124.00  | 13.75  | 1.67790        | 55.52          |
| 4  | -1821.25 | 22.50 | 1.80518        | 25.46          | 14 | -473.63 | 0.25   |                |                |
| 5  | -217.00  | 7.50  | 1.62041        | 60.98          | 15 | 56.31   | 14.88  | 1.69680        | 55.61          |
| 6  | 102.06   | *** 2 |                |                | 16 | 85.50   | 7.50   |                |                |
| 7  | -142.56  | 6.25  | 1.62004        | 36.34          | 17 | -177.50 | 19.69  | 1.78470        | 26.10          |
| 8  | -3618.75 | *** 3 |                |                | 18 | 46.84   | 8.13   |                |                |
| 9  | 275.63   | 12.50 | 1.52015        | 63.59          | 19 | 93.00   | 14.38  | 1.74400        | 44.90          |
| 10 | -220.31  | 3.13  |                |                | 20 | -71.94  |        |                |                |

15.63\* = 5.63 + 10.00

04-03-013-1

|                | $\Sigma S_1$ | $\Sigma S_2$ | $\Sigma S_3$ | $\Sigma S_4$ | $\Sigma S_5$  | HI        | QP(1 $\omega$ ) |
|----------------|--------------|--------------|--------------|--------------|---------------|-----------|-----------------|
|                | -0.1053      | -0.0337      | 0.0050       | -0.0154      | -0.0347       | 8.08      | -0.75%          |
| h 或 $\omega$ % | LA'          | $\Delta H'$  | $x'_t$       | $x'_s$       | $x'_t - x'_s$ | $K'_{T1}$ | $K'_{T0.7}$     |
| 100            | -0.264       | -0.061       | -0.0110      | -0.0670      | 0.0560        | 0.2356    | -0.0070         |
| 70             | -0.270       | -0.022       | -0.0051      | -0.0345      | 0.0294        | 0.1447    | -0.0123         |

E. F. L = 50 ( $\pm 9.1^\circ$ )

\*\*\*1 = 6.15; \*\*\*2 = 180.15; \*\*\*3 = 68.14

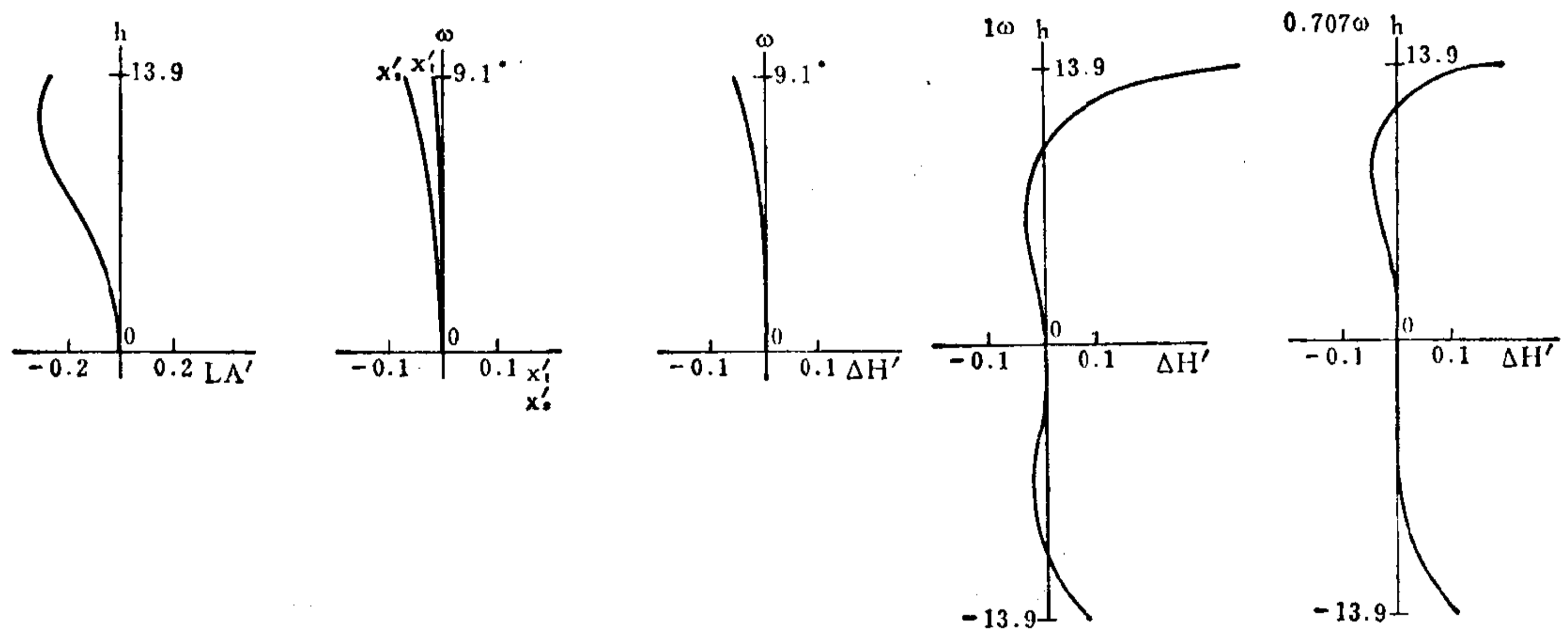

04-03-013-2

|                | $\Sigma S_1$ | $\Sigma S_2$ | $\Sigma S_3$ | $\Sigma S_4$ | $\Sigma S_5$  | HI        | QP(1 $\omega$ ) |
|----------------|--------------|--------------|--------------|--------------|---------------|-----------|-----------------|
|                | -0.0820      | -0.0229      | -0.0091      | -0.0154      | -0.0014       | 8.02      | -0.06%          |
| h 或 $\omega$ % | LA'          | $\Delta H'$  | $x'_t$       | $x'_s$       | $x'_t - x'_s$ | $K'_{T1}$ | $K'_{T0.7}$     |
| 100            | -0.119       | -0.0047      | -0.254       | -0.153       | -0.101        | 0.3099    | 0.0213          |
| 70             | -0.197       | -0.0013      | -0.135       | -0.079       | -0.056        | 0.1900    | 0.0076          |

E. F. L = 100 ( $\pm 4.6^\circ$ )

\*\*\*1 = 127.19; \*\*\*2 = 61.00; \*\*\*3 = 66.25

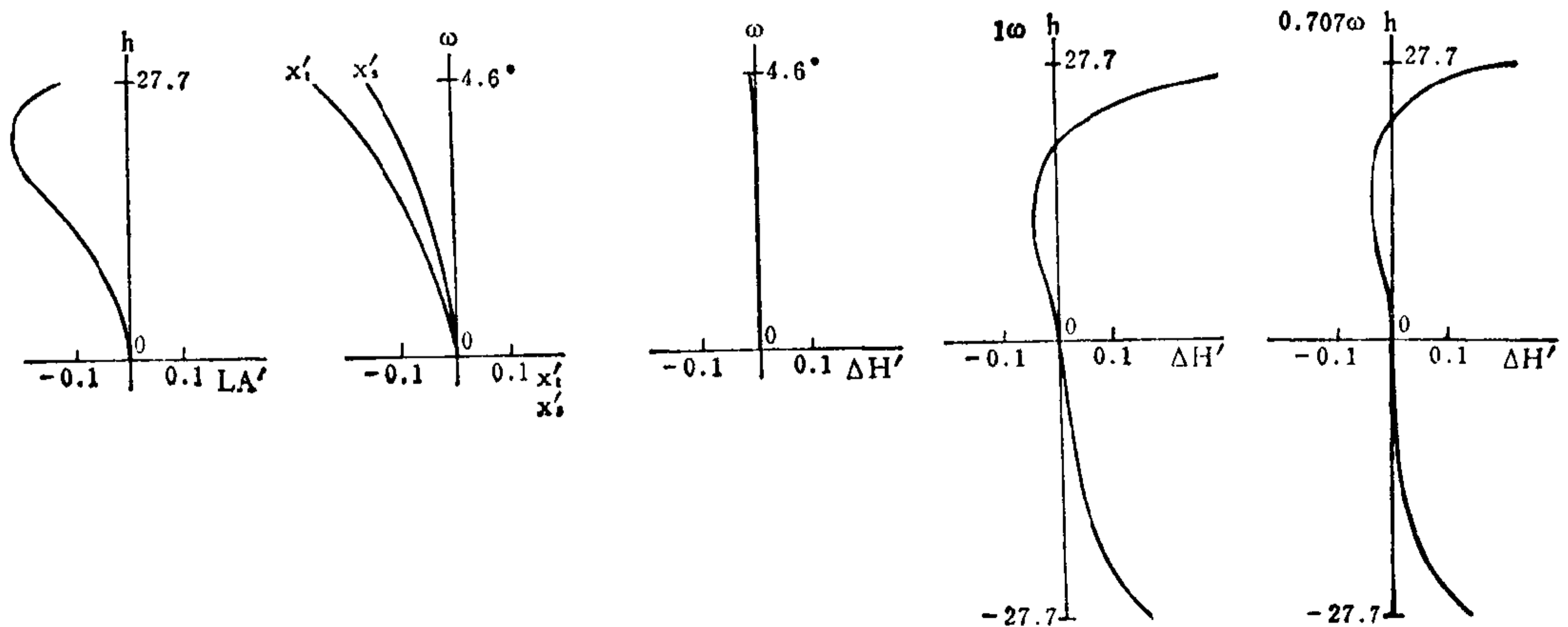

04-03-013-3

|                | $\Sigma S_1$ | $\Sigma S_2$ | $\Sigma S_3$ | $\Sigma S_4$ | $\Sigma S_5$  | HI        | QP(1 $\omega$ ) |
|----------------|--------------|--------------|--------------|--------------|---------------|-----------|-----------------|
|                | -0.0913      | 0.0218       | -0.0203      | -0.0155      | 0.0158        | 8         | 0.33%           |
| h 或 $\omega$ % | LA'          | $\Delta H'$  | $x'_t$       | $x'_s$       | $x'_t - x'_s$ | $K'_{T1}$ | $K'_{T0.7}$     |
| 100            | -0.171       | 0.0268       | -0.445       | -0.220       | -0.225        | 0.5254    | 0.1303          |
| 70             | -0.220       | 0.0097       | -0.235       | -0.113       | -0.122        | 0.3531    | 0.0895          |

E. F. L = 200 ( $\pm 2.3^\circ$ )

\*\*\*1 = 214.52; \*\*\*2 = 12.90; \*\*\*3 = 27.02

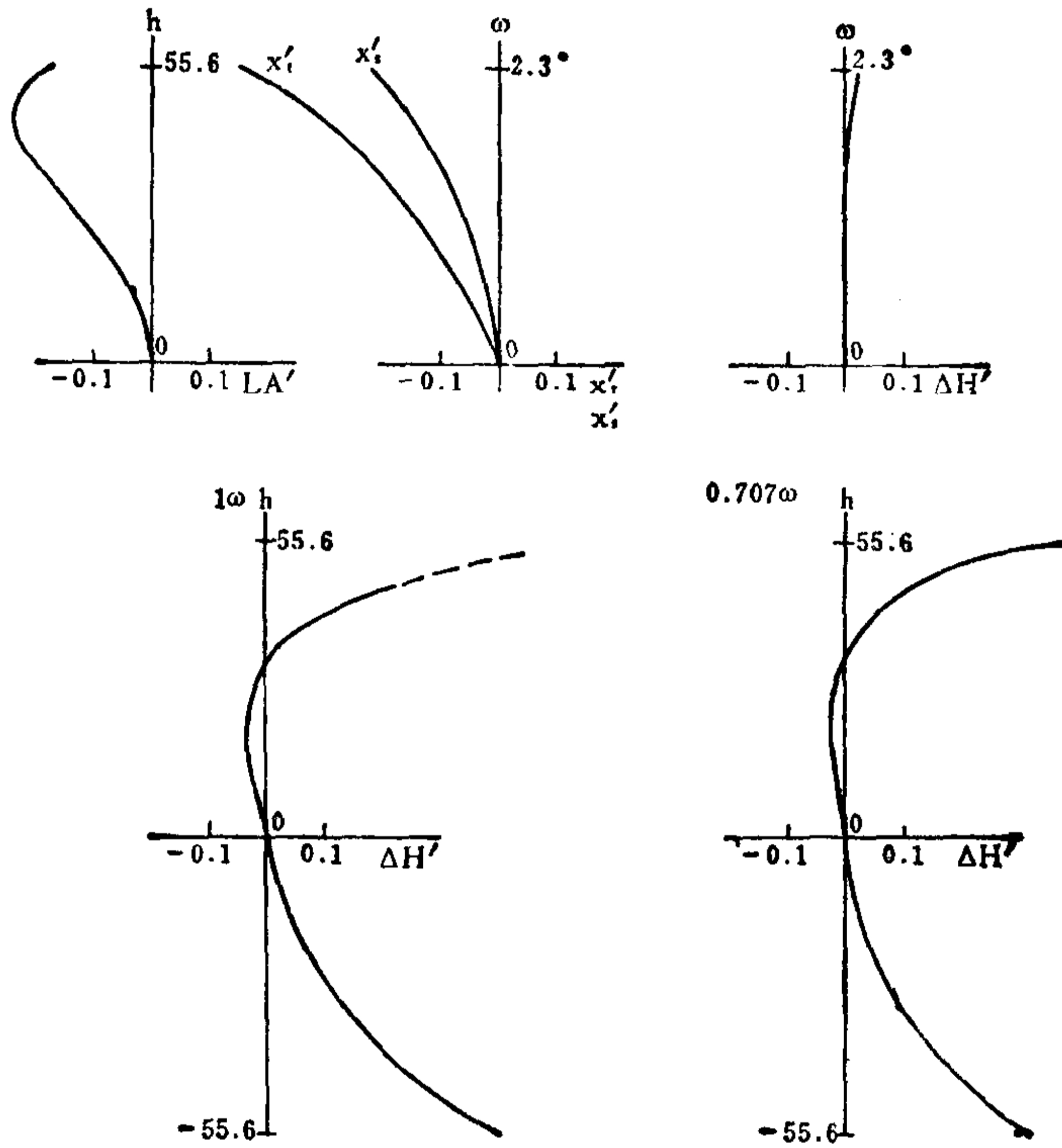

编号: 04-03-014

## 变 焦 距 镜 头

E.F.L=76.79~153.60 B.F.L=43.18 FNo.=4 F.A.=±17.9°~±9.0°

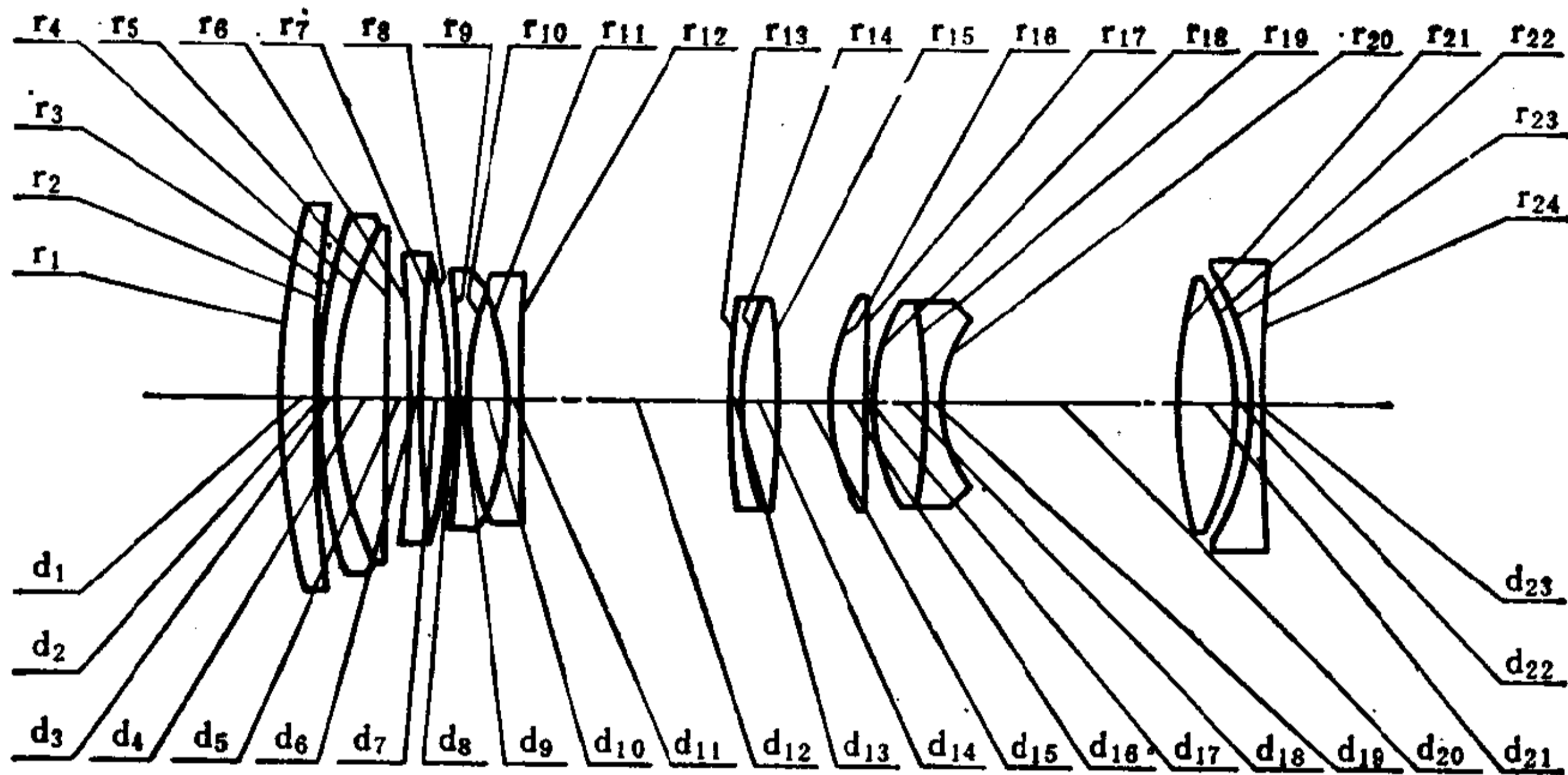

| 序号 | r        | d     | n <sub>d</sub> | v     | 序号 | r        | d      | n <sub>d</sub> | v     |
|----|----------|-------|----------------|-------|----|----------|--------|----------------|-------|
| 1  | 78.829   | 4.09  | 1.51633        | 64.15 | 13 | 84.070   | 1.13   | 1.74077        | 27.79 |
| 2  | 441.679  | 0.19  |                |       | 14 | 36.191   | 3.95   | 1.6223         | 53.2  |
| 3  | 74.639   | 1.90  | 1.74077        | 27.79 | 15 | -105.440 | 6.707* |                |       |
| 4  | 44.110   | 5.80  | 1.51821        | 65.04 | 16 | 24.560   | 4.78   | 1.51633        | 64.15 |
| 5  | 1742.450 | *** 1 |                |       | 17 | ∞        | 0.38   |                |       |
| 6  | -175.362 | 1.70  | 1.618          | 63.38 | 18 | 24.442   | 6.12   | 1.51009        | 63.63 |
| 7  | 133.175  | 2.96  | 1.7846         | 26.22 | 19 | -61.605  | 2.00   | 1.744          | 44.78 |
| 8  | -80.740  | 0.38  |                |       | 20 | 17.088   | 28.87  |                |       |
| 9  | -214.635 | 1.43  | 1.5725         | 57.65 | 21 | 57.836   | 7.00   | 1.60342        | 38.01 |
| 10 | 39.980   | 5.26  |                |       | 22 | -31.791  | 1.43   |                |       |
| 11 | -35.068  | 1.43  | 1.618          | 63.38 | 23 | -30.887  | 1.43   | 1.66998        | 39.32 |
| 12 | 626.880  | *** 2 |                |       | 24 | 455.310  |        |                |       |

6.707\* = 3.000 + 3.707



04-03-014-1

|                | $\Sigma S_1$ | $\Sigma S_2$ | $\Sigma S_3$ | $\Sigma S_4$ | $\Sigma S_5$  | HI        | QP(1 $\omega$ ) |
|----------------|--------------|--------------|--------------|--------------|---------------|-----------|-----------------|
|                | -0.0229      | -0.0103      | -0.0029      | -0.0159      | -0.1741       | 24.85     | -3.3%           |
| h 或 $\omega$ % | LA'          | $\Delta H'$  | $x'_t$       | $x'_s$       | $x'_t - x'_s$ | $K'_{T1}$ | $K'_{T0.7}$     |
| 100            | 0.125        | -0.820       | -0.0378      | 0.1100       | -0.1478       | -1.9345   | 0.0481          |
| 70             | -0.201       | -0.278       | 0.0447       | -0.1087      | 0.1534        | 0.0423    | 0.0043          |

E. F. L = 76.79 ( $\pm 17.9^\circ$ )

\*\*\*1 = 2.086, \*\*\*2 = 25.371

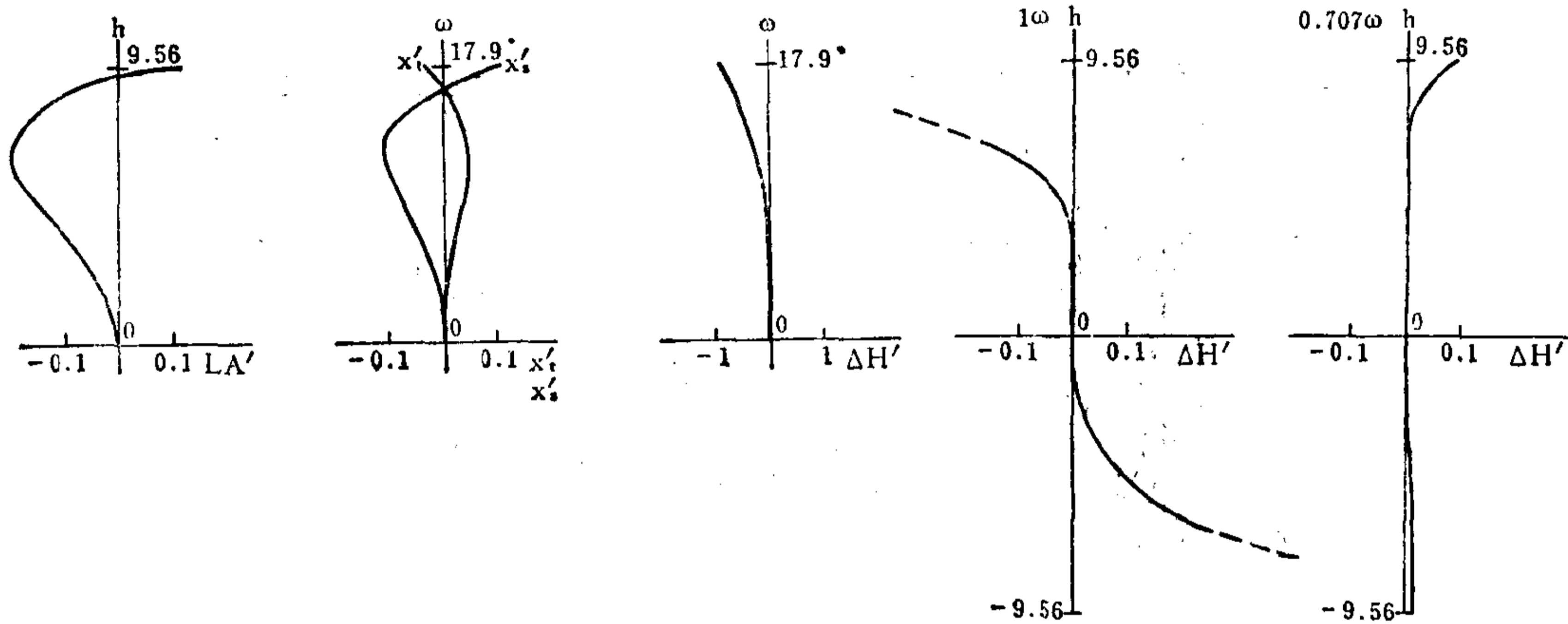

04-03-014-2

|                | $\Sigma S_1$ | $\Sigma S_2$ | $\Sigma S_3$ | $\Sigma S_4$ | $\Sigma S_5$  | HI        | QP(1 $\omega$ ) |
|----------------|--------------|--------------|--------------|--------------|---------------|-----------|-----------------|
|                | -0.0169      | -0.0154      | 0.0039       | -0.0163      | 0.1829        | 24.28     | 3.02%           |
| h 或 $\omega$ % | LA'          | $\Delta H'$  | $x'_t$       | $x'_s$       | $x'_t - x'_s$ | $K'_{T1}$ | $K'_{T0.7}$     |
| 100            | 0.085        | 0.734        | 0.343        | 0.104        | 0.239         | -2.2351   | -0.0426         |
| 70             | -0.164       | 0.265        | 0.125        | -0.088       | 0.213         | 0.0298    | 0.0036          |

E. F. L = 153.60 ( $\pm 9.0^\circ$ )

\*\*\*1 = 26.433, \*\*\*2 = 1.024

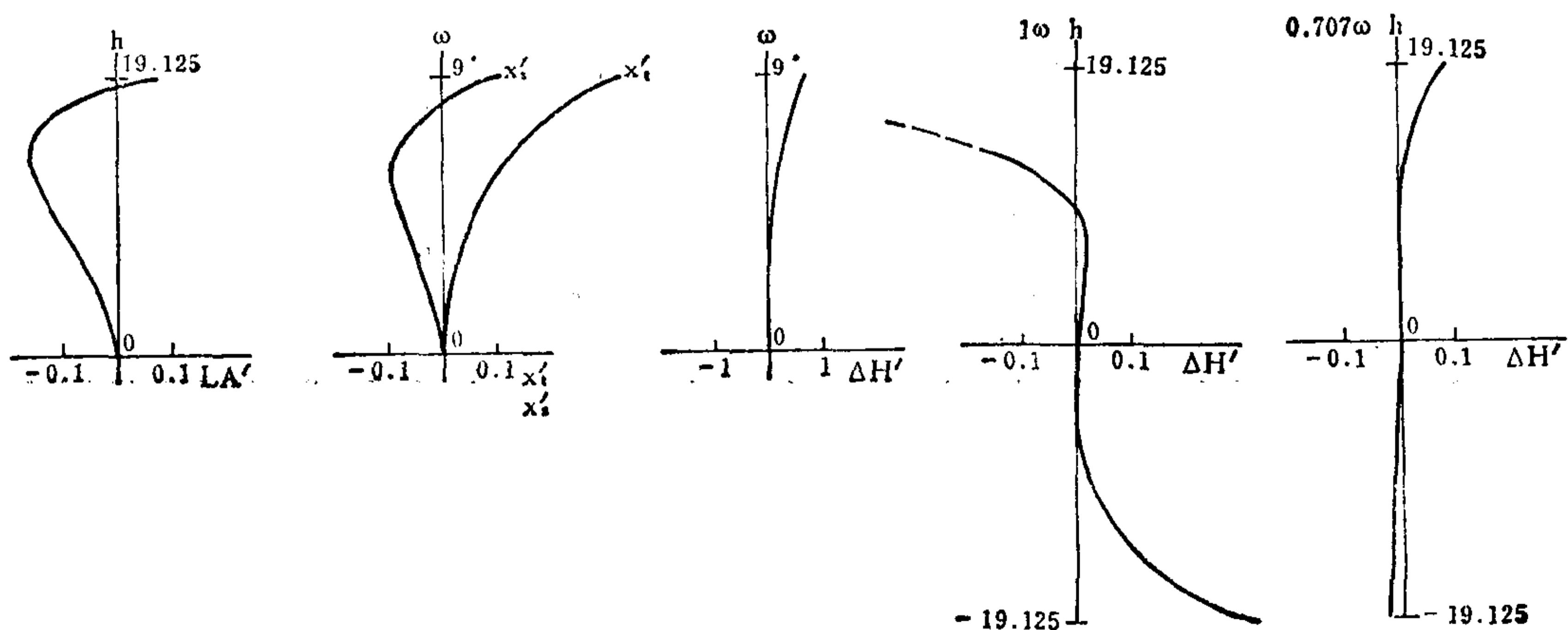

编号: 04-03-015

# 变 焦 距 镜 头

E.F.L=76.5~153.0 B.F.L=44.39 FNo.=4 F.A.=±17.9°~±9.0°

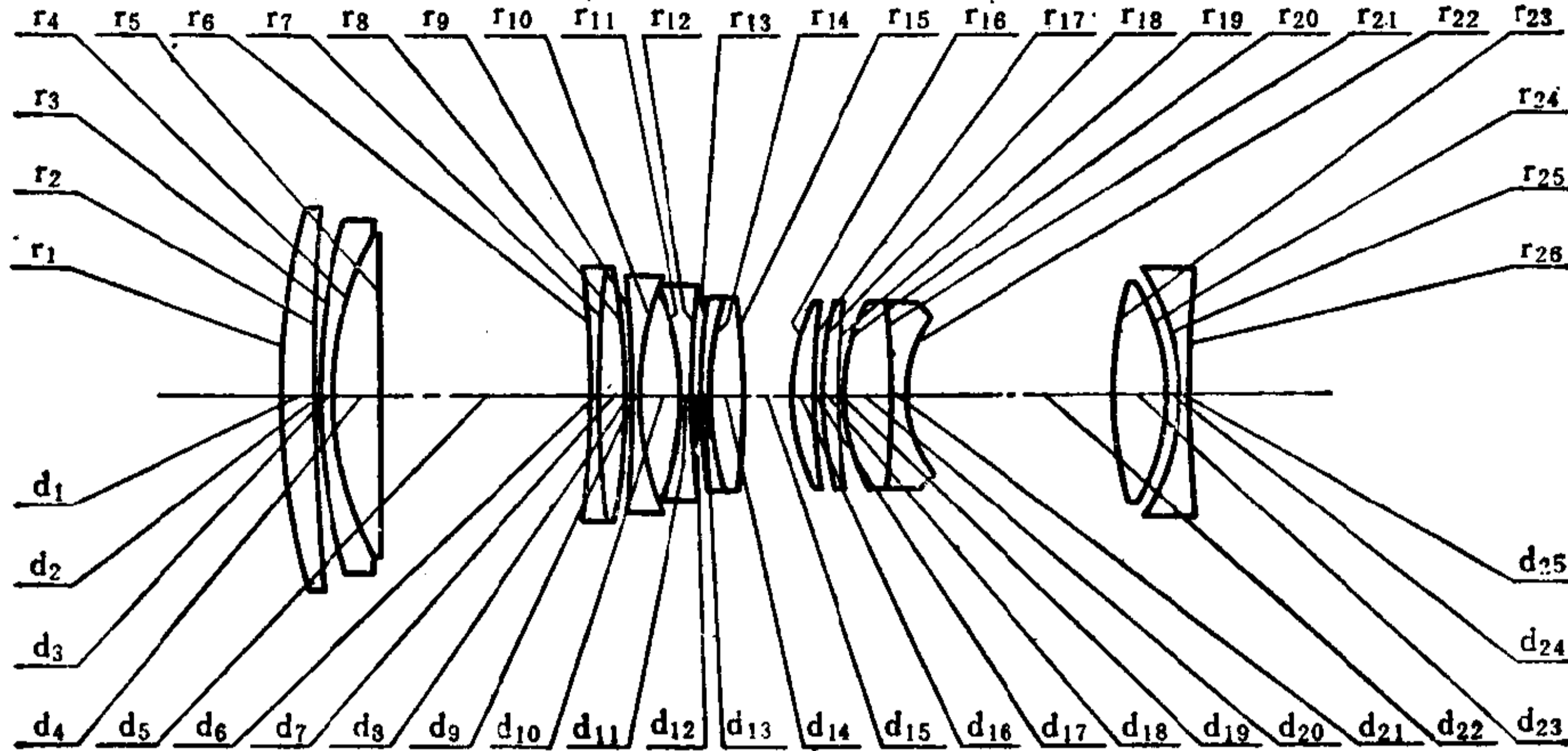

| 序号 | r        | d     | n <sub>d</sub> | v     | 序号 | r        | d      | n <sub>d</sub> | v     |
|----|----------|-------|----------------|-------|----|----------|--------|----------------|-------|
| 1  | 78.828   | 4.09  | 1.51633        | 64.15 | 14 | 36.191   | 3.95   | 1.6223         | 53.2  |
| 2  | 441.679  | 0.19  |                |       | 15 | -105.440 | 6.707* |                |       |
| 3  | 74.639   | 1.90  | 1.74077        | 27.79 | 16 | 25.913   | 3.30   | 1.50378        | 66.81 |
| 4  | 44.110   | 5.80  | 1.51821        | 65.04 | 17 | 108.255  | 0.15   |                |       |
| 5  | 1742.450 | *** 1 |                |       | 18 | 46.923   | 2.50   | 1.50048        | 65.99 |
| 6  | -175.362 | 1.70  | 1.618          | 63.38 | 19 | 98.549   | 0.20   |                |       |
| 7  | 133.175  | 2.96  | 1.7847         | 26.22 | 20 | 24.830   | 5.74   | 1.50378        | 66.81 |
| 8  | -80.740  | 0.38  |                |       | 21 | -115.109 | 2.00   | 1.744          | 44.78 |
| 9  | -214.635 | 1.43  | 1.5725         | 57.65 | 22 | 16.950   | 26.00  |                |       |
| 10 | 39.980   | 5.26  |                |       | 23 | 51.876   | 7.00   | 1.60717        | 40.34 |
| 11 | -35.068  | 1.43  | 1.618          | 63.38 | 24 | -28.103  | 1.44   |                |       |
| 12 | 626.880  | *** 2 |                |       | 25 | -26.962  | 1.43   | 1.66755        | 41.93 |
| 13 | 84.070   | 1.13  | 1.74077        | 27.79 | 26 | 248.554  |        |                |       |

6.707\* = 4.707 + 2.000

04-03-015-1

|                | $\Sigma S_1$ | $\Sigma S_2$ | $\Sigma S_3$ | $\Sigma S_4$ | $\Sigma S_5$  | HI        | QP(1 $\omega$ ) |
|----------------|--------------|--------------|--------------|--------------|---------------|-----------|-----------------|
|                | -0.0093      | -0.0044      | -0.0039      | -0.0124      | -0.1669       | 24.76     | -3.3%           |
| h 或 $\omega$ % | LA'          | $\Delta H'$  | $x'_t$       | $x'_s$       | $x'_t - x'_s$ | $K'_{T1}$ | $K'_{T0.7}$     |
| 100            | 0.044        | -0.808       | -0.5780      | 0.1050       | -0.6830       | -1.6051   | -0.5481         |
| 70             | -0.076       | -0.269       | -0.0078      | -0.0794      | 0.0716        | -0.2382   | -0.0036         |

E. F. L = 76.5 ( $\pm 17.9^\circ$ )

\*\*\* 1 = 2.086; \*\*\* 2 = 25.371

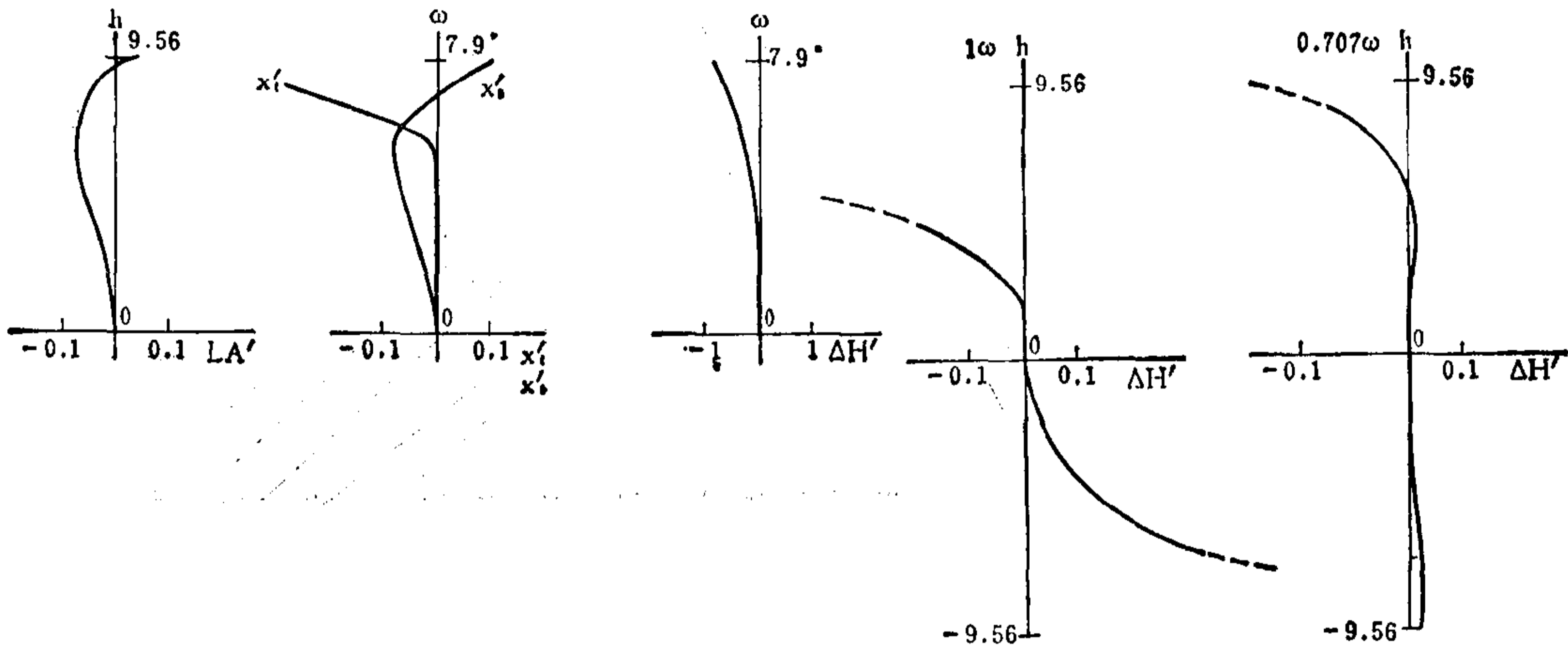

04-03-015-2

|                | $\Sigma S_1$ | $\Sigma S_2$ | $\Sigma S_3$ | $\Sigma S_4$ | $\Sigma S_5$  | HI        | QP(1 $\omega$ ) |
|----------------|--------------|--------------|--------------|--------------|---------------|-----------|-----------------|
|                | -0.0034      | -0.0101      | 0.0030       | -0.0128      | 0.1897        | 24.19     | 3.04%           |
| h 或 $\omega$ % | LA'          | $\Delta H'$  | $x'_t$       | $x'_s$       | $x'_t - x'_s$ | $K'_{T1}$ | $K'_{T0.7}$     |
| 100            | -0.0007      | 0.736        | -0.3590      | 0.0830       | -0.4420       | -2.4037   | -0.7668         |
| 70             | -0.0394      | 0.271        | 0.0635       | -0.0564      | 0.1199        | -0.1967   | -0.0044         |

E. F. L = 153.0 ( $\pm 9.0^\circ$ )

\*\*\* 1 = 26.433; \*\*\* 2 = 1.024

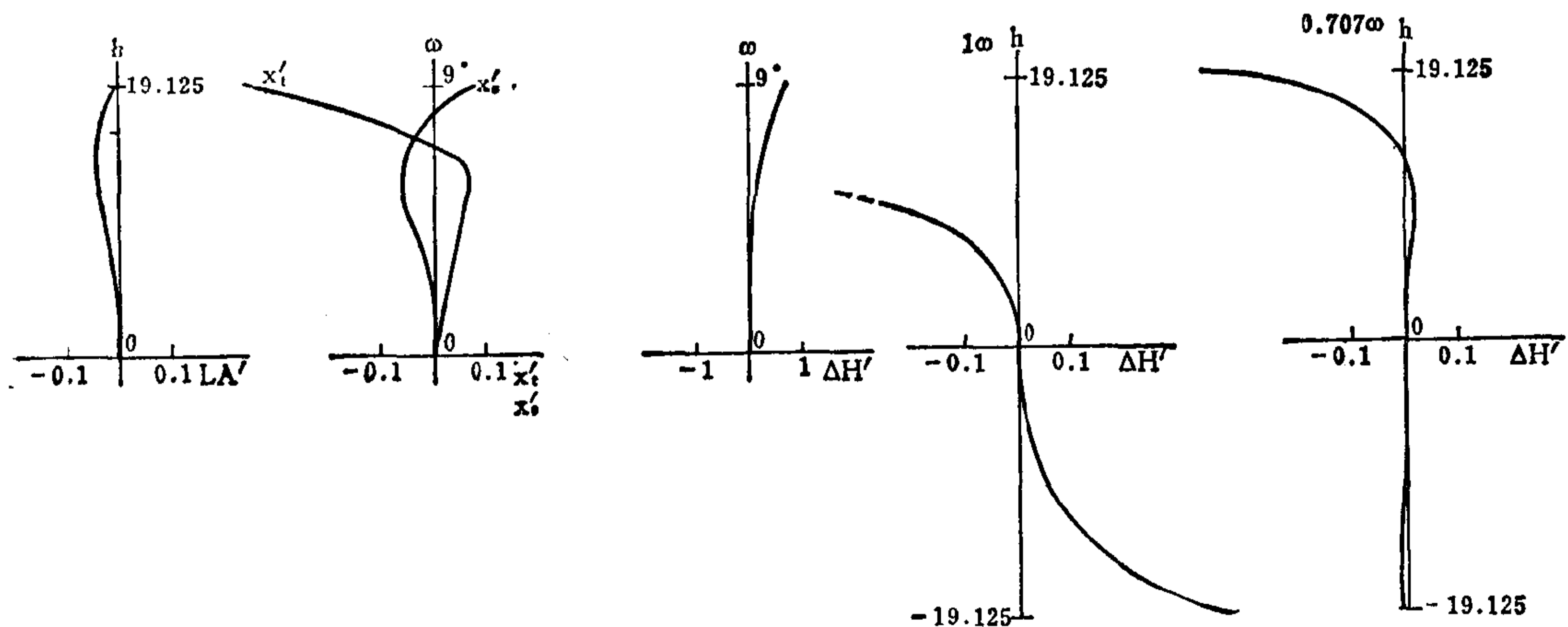

编号: 04-03-016

# 大孔径变焦距物镜

E.F.L = 30~180    B.F.L = 46.9    FNo. = 1.4    F.A. = ±15.3° ~ ±2.5°

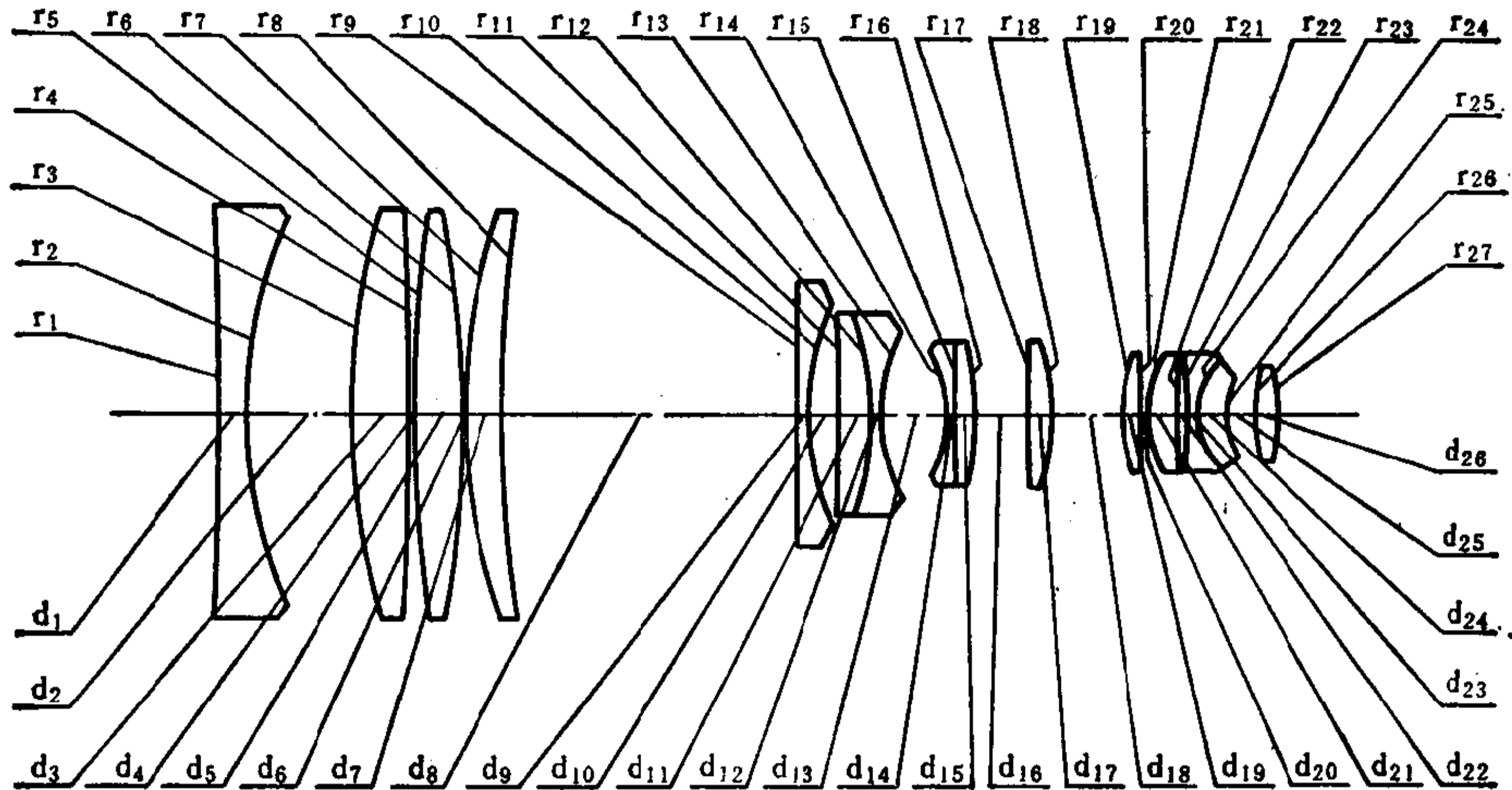

| 序号 | r        | d     | nd      | vd    | 序号 | r       | d      | nd      | vd    |
|----|----------|-------|---------|-------|----|---------|--------|---------|-------|
| 1  | -1339.00 | 15.00 | 1.78470 | 26.10 | 15 | 872.75  | 10.50  | 1.64831 | 33.77 |
| 2  | 249.80   | 56.50 |         |       | 16 | -168.25 | *** 3  |         |       |
| 3  | 385.40   | 30.00 | 1.69938 | 49.57 | 17 | 1002.00 | 11.00  | 1.65844 | 50.8  |
| 4  | -1434.00 | 0.90  |         |       | 18 | -126.25 | 38.00  |         |       |
| 5  | 1025.00  | 25.75 | 1.67790 | 55.52 | 19 | 102.80  | 10.75  | 1.71300 | 53.89 |
| 6  | -537.20  | 1.35  |         |       | 20 | 1087.00 | 0.50   |         |       |
| 7  | 308.80   | 22.50 | 1.67790 | 55.52 | 21 | 62.95   | 17.00  | 1.71300 | 53.89 |
| 8  | 980.75   | *** 1 |         |       | 22 | 1169.50 | 1.50   |         |       |
| 9  | 10000.00 | 7.50  | 1.62041 | 60.29 | 23 | -475.00 | 7.75   | 1.80518 | 25.46 |
| 10 | 139.75   | 15.50 |         |       | 24 | 38.93   | 15.00  | 1.71300 | 53.89 |
| 11 | -1502.00 | 17.00 | 1.80518 | 25.46 | 25 | 40.83   | 16.25* |         |       |
| 12 | -160.70  | 5.00  | 1.52542 | 64.55 | 26 | 100.50  | 10.75  | 1.71300 | 53.89 |
| 13 | 92.75    | *** 2 |         |       | 27 | -124.65 |        |         |       |
| 14 | -66.00   | 4.00  | 1.62041 | 60.29 |    |         |        |         |       |

16.25\* = 8.25 + 8.00

04-03-016-1

|                | $\Sigma S_1$ | $\Sigma S_2$ | $\Sigma S_3$ | $\Sigma S_4$ | $\Sigma S_5$  | HI        | QP(1 $\omega$ ) |
|----------------|--------------|--------------|--------------|--------------|---------------|-----------|-----------------|
|                | -0.3805      | 0.0133       | 0.0101       | -0.0065      | -0.0626       | 8.22      | -1.02%          |
| h 或 $\omega$ % | LA'          | $\Delta H'$  | $x'_t$       | $x'_s$       | $x'_t - x'_s$ | $K'_{T1}$ | $K'_{T0.7}$     |
| 100            | 0.1515       | -0.0841      | 0.0958       | 0.0199       | 0.0759        | -0.1839   | 0.00776         |
| 70             | -0.4597      | -0.0311      | 0.0475       | 0.0082       | 0.0393        | -0.1557   | 0.00688         |

E. F. L = 30 ( $\pm 15.3^\circ$ )

\*\*\*1 = 9.25, \*\*\*2 = 187.40, \*\*\*3 = 23.85

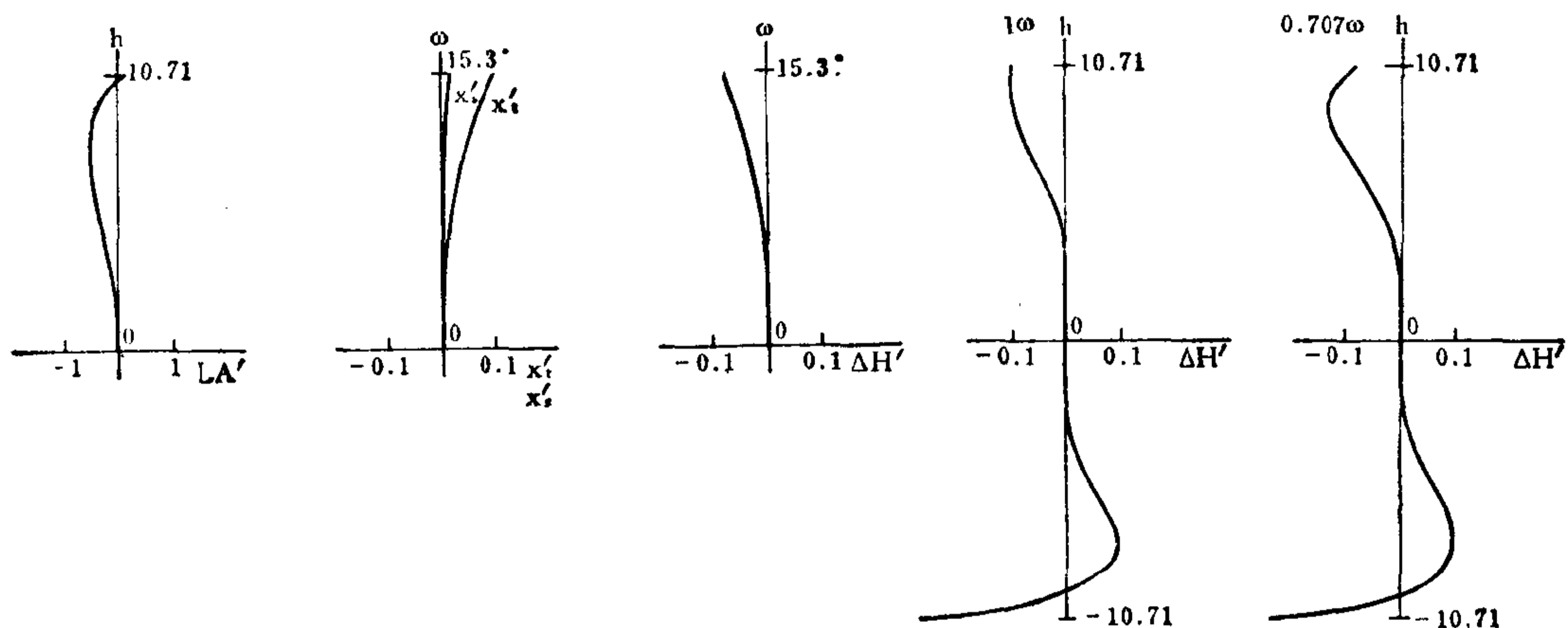

04-03-016-2

|                | $\Sigma S_1$ | $\Sigma S_2$ | $\Sigma S_3$ | $\Sigma S_4$ | $\Sigma S_5$  | HI        | QP(1 $\omega$ ) |
|----------------|--------------|--------------|--------------|--------------|---------------|-----------|-----------------|
|                | -0.2443      | 0.0615       | -0.0286      | -0.0067      | 0.0353        | 8.02      | 0.52%           |
| h 或 $\omega$ % | LA'          | $\Delta H'$  | $x'_t$       | $x'_s$       | $x'_t - x'_s$ | $K'_{T1}$ | $K'_{T0.7}$     |
| 100            | 0.673        | 0.0416       | -0.272       | -0.115       | -0.157        | -0.0332   | 0.0965          |
| 70             | -0.185       | 0.0158       | -0.154       | -0.062       | -0.092        | -0.0122   | 0.0685          |

E. F. L = 100 ( $\pm 4.6^\circ$ )

\*\*\*1 = 155.70, \*\*\*2 = 34.80, \*\*\*3 = 30.00

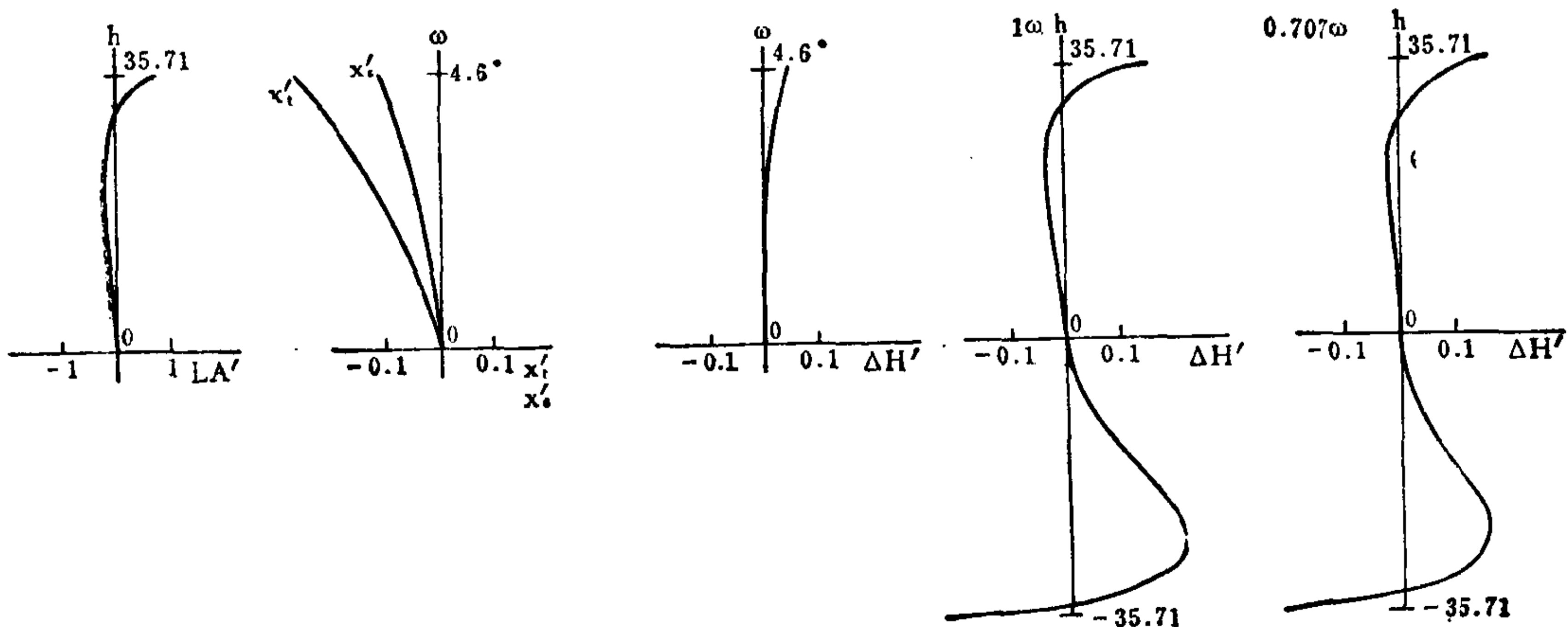

04-03-016-3

|                | $\Sigma S_1$ | $\Sigma S_2$ | $\Sigma S_3$ | $\Sigma S_4$ | $\Sigma S_5$  | HI        | QP(1 $\omega$ ) |
|----------------|--------------|--------------|--------------|--------------|---------------|-----------|-----------------|
|                | 0.08271      | -0.03146     | 0.00848      | -0.00657     | 0.02158       | 7.9       | 0.32%           |
| h 或 $\omega$ % | LA'          | $\Delta H'$  | $x'_i$       | $x'_s$       | $x'_i - x'_s$ | $K'_{T1}$ | $K'_{T0.7}$     |
| 100            | 1.713        | 0.0256       | 0.1268       | 0.0211       | 0.1057        | 1.8261    | 0.1459          |
| 70             | 0.397        | 0.0098       | 0.0528       | 0.0073       | 0.0455        | 0.3758    | 0.0102          |

E. F. L = 180 ( $\pm 2.5^\circ$ )

\*\*\*1 = 200.60; \*\*\*2 = 14.70; \*\*\*3 = 5.20

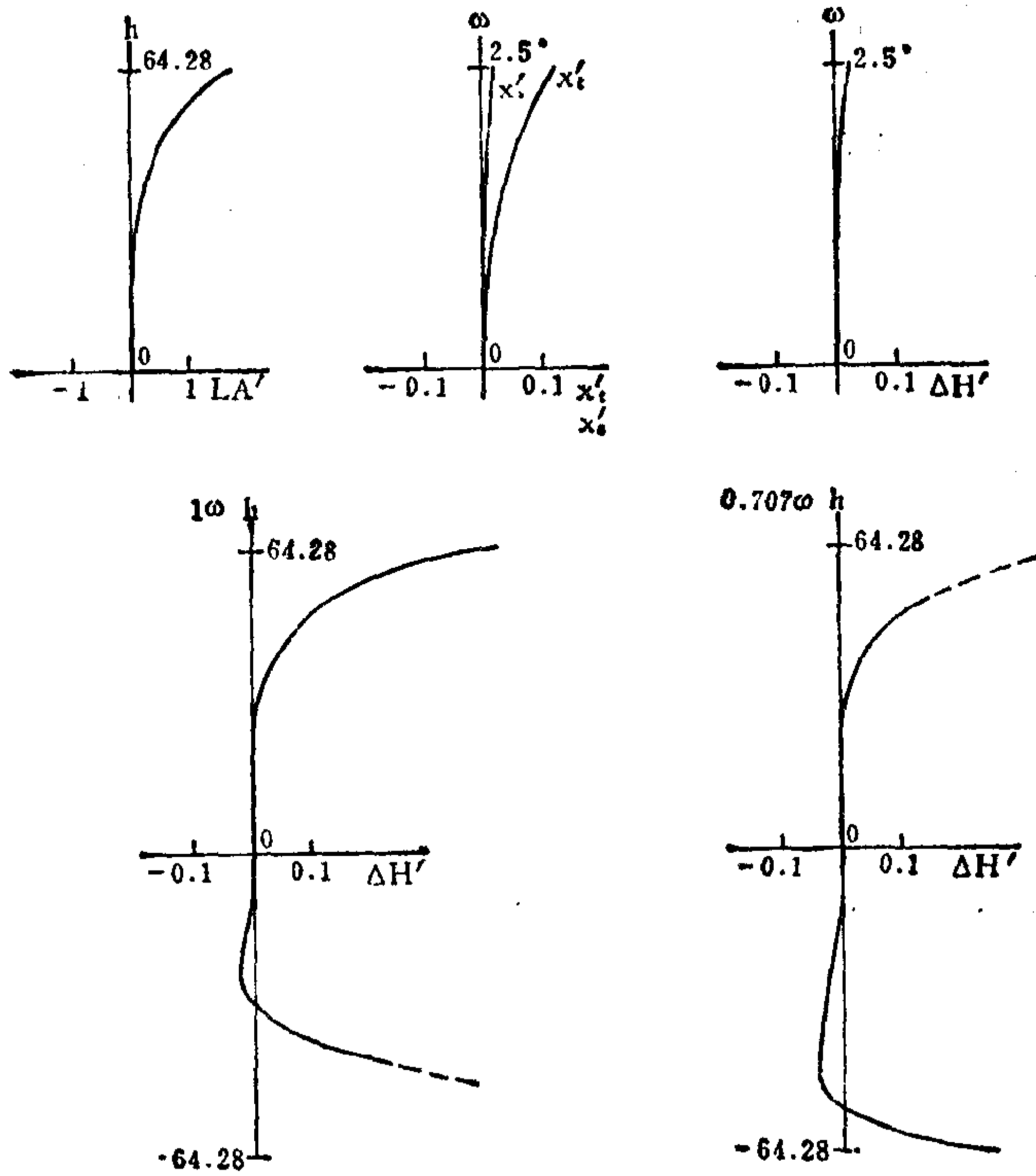

编号: 04-03-017

## 两个可动负组在两个固定正组间的变焦距镜头

E.F.L.=7.50~30.00 B.F.L.=11.658 FNo.=1.7 F.A.=±11.3°~±2.8°

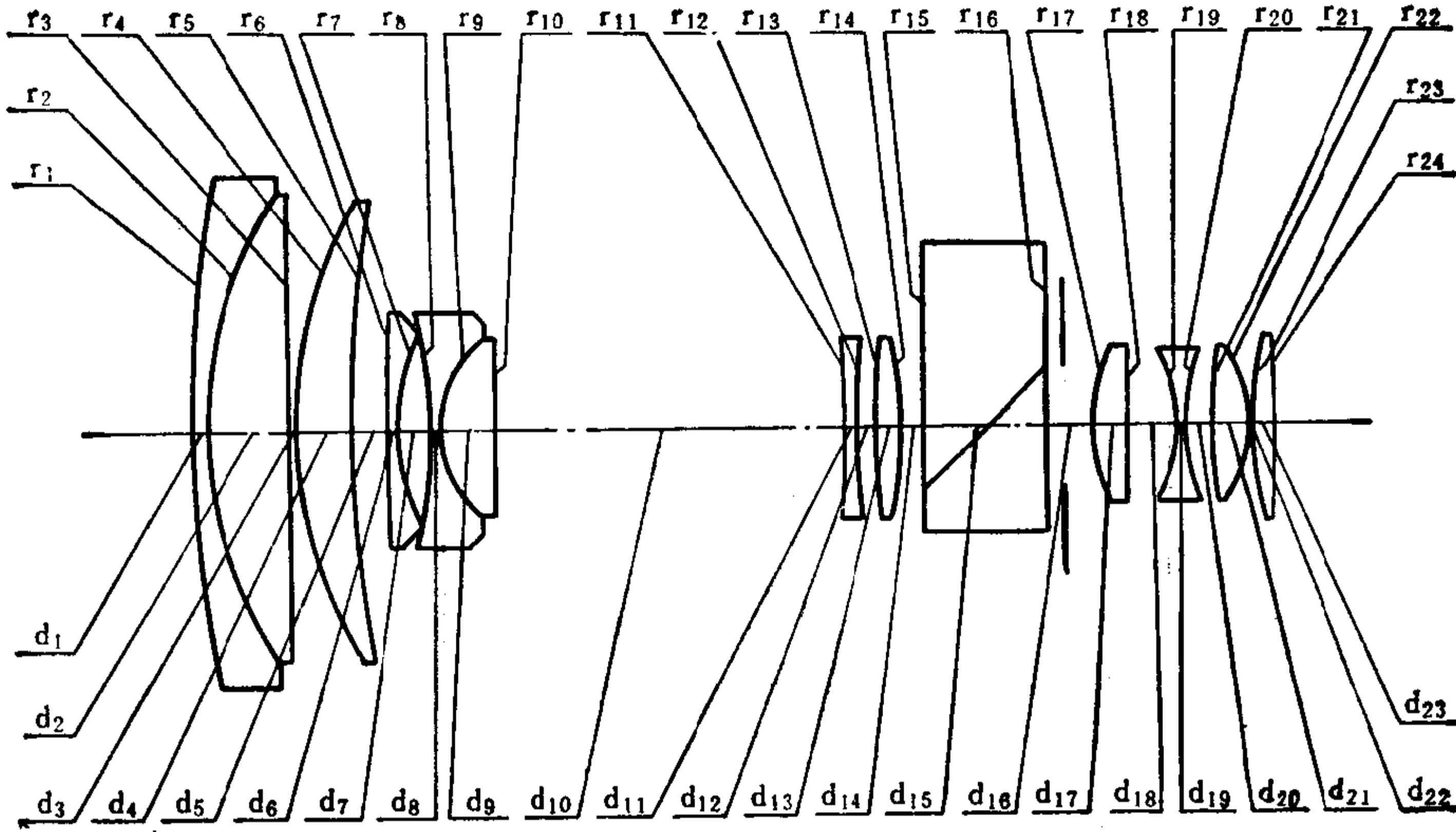

| 序号 | r       | d     | n      | v <sub>D</sub> | 序号 | r       | d     | n      | v <sub>D</sub> |
|----|---------|-------|--------|----------------|----|---------|-------|--------|----------------|
| 1  | 90.30   | 1.00  | 1.6990 | 30.1           | 13 | 66.83   | 1.70  | 1.6935 | 53.4           |
| 2  | 28.76   | 5.90  | 1.6073 | 59.5           | 14 | -28.87  | 1.50  |        |                |
| 3  | -762.36 | 0.10  |        |                | 15 | ∞       | 8.50  | 1.6200 | 36.3           |
| 4  | 30.68   | 4.10  | 1.6204 | 60.3           | 16 | ∞       | 3.00* |        |                |
| 5  | 112.58  | *** 1 |        |                | 17 | 11.92   | 2.40  | 1.7440 | 44.9           |
| 6  | 326.18  | 0.57  | 1.6385 | 55.5           | 18 | ∞       | 3.40  |        |                |
| 7  | 14.12   | 2.30  |        |                | 19 | -10.10  | 0.80  | 1.7847 | 25.7           |
| 8  | -32.26  | 0.57  | 1.6935 | 53.4           | 20 | 13.93   | 1.80  |        |                |
| 9  | 7.80    | 3.80  | 1.6727 | 32.2           | 21 | 60.56   | 2.40  | 1.7200 | 50.3           |
| 10 | 543.87  | *** 2 |        |                | 22 | -9.43   | 0.12  |        |                |
| 11 | -95.02  | 1.00  | 1.7847 | 25.7           | 23 | 24.22   | 1.50  | 1.6935 | 53.4           |
| 12 | 95.02   | *** 3 |        |                | 24 | -197.77 |       |        |                |

3.00\* = 1.00 + 2.00



04-03-017-1

|                | $\Sigma S_1$ | $\Sigma S_2$ | $\Sigma S_3$ | $\Sigma S_4$ | $\Sigma S_5$  | HI        | QP(1 $\omega$ ) |
|----------------|--------------|--------------|--------------|--------------|---------------|-----------|-----------------|
|                | -0.04982     | -0.00792     | -0.00204     | -0.00266     | -0.01175      | 1.5       | -1.4%           |
| h 或 $\omega$ % | LA'          | $\Delta H'$  | $x'_i$       | $x'_s$       | $x'_i - x'_s$ | $K'_{T1}$ | $K'_{T0.7}$     |
| 100            | 0.0458       | -0.0210      | -0.0464      | -0.0260      | -0.0204       | 0.09696   | -0.00064        |
| 70             | -0.0896      | -0.0073      | -0.0245      | -0.0134      | -0.0111       | 0.06222   | -0.00187        |

E. F. L = 7.50 ( $\pm 11.3^\circ$ )

\*\*\*1 = 2.30; \*\*\*2 = 23.94; \*\*\*3 = 1.20

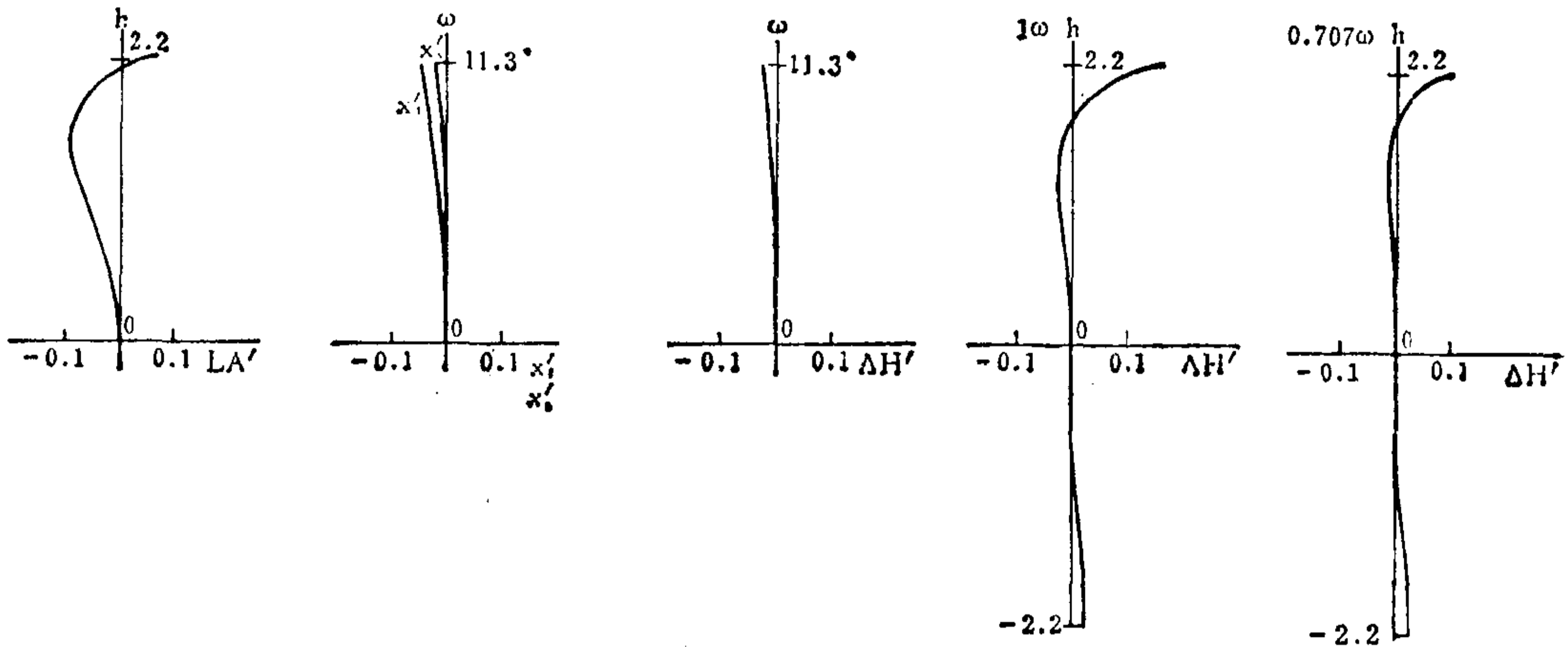

04-03-017-2

|                | $\Sigma S_1$ | $\Sigma S_2$ | $\Sigma S_3$ | $\Sigma S_4$ | $\Sigma S_5$  | HI        | QP(1 $\omega$ ) |
|----------------|--------------|--------------|--------------|--------------|---------------|-----------|-----------------|
|                | -0.04402     | -0.00965     | -0.00052     | -0.00273     | -0.00242      | 1.5       | -0.29%          |
| h 或 $\omega$ % | LA'          | $\Delta H'$  | $x'_i$       | $x'_s$       | $x'_i - x'_s$ | $K'_{T1}$ | $K'_{T0.7}$     |
| 100            | 0.0939       | -0.0043      | -0.0237      | -0.0185      | -0.0052       | 0.09670   | -0.00579        |
| 70             | -0.0713      | -0.0015      | -0.0130      | -0.0096      | -0.0034       | 0.05748   | -0.00585        |

E. F. L = 16.60 ( $\pm 5.1^\circ$ )

\*\*\*1 = 16.30; \*\*\*2 = 6.39; \*\*\*3 = 4.75

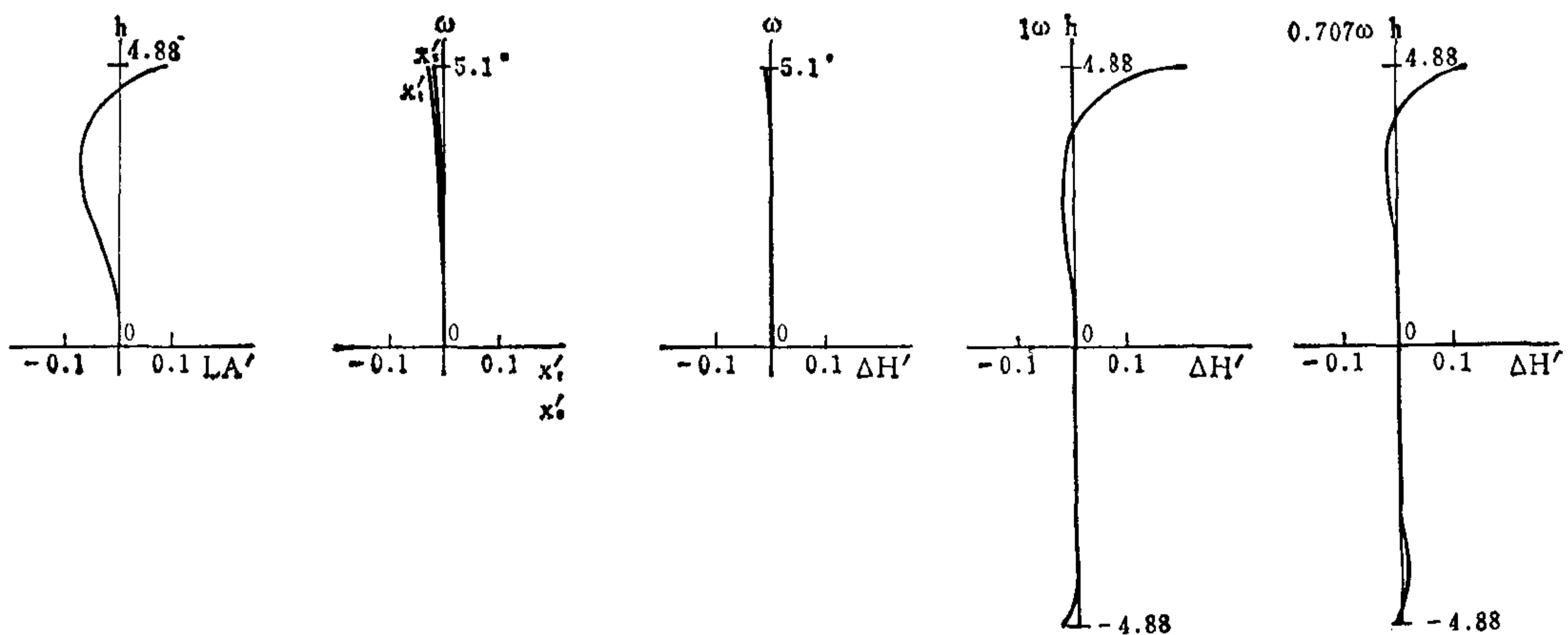



04-03-017-3

|                | $\Sigma S_1$ | $\Sigma S_2$ | $\Sigma S_3$ | $\Sigma S_4$ | $\Sigma S_5$ | HI        | QP(1 $\omega$ ) |
|----------------|--------------|--------------|--------------|--------------|--------------|-----------|-----------------|
|                | -0.02414     | -0.00985     | 0.00129      | -0.00276     | -0.00045     | 1.5       | -0.06%          |
| h 或 $\omega$ % | LA'          | $\Delta H'$  | $x_t$        | $x_s$        | $x_t - x_s$  | $K'_{f1}$ | $K'_{r0.7}$     |
| 100            | 0.2389       | -0.0009      | 0.0141       | -0.0066      | 0.0207       | 0.08145   | -0.00907        |
| 70             | -0.0099      | -0.0003      | 0.0049       | -0.0038      | 0.0087       | 0.04891   | -0.00740        |

E. F. L = 30.00 ( $\pm 2.8^\circ$ )

\*\*\*1 = 23.30, \*\*\*2 = 2.94, \*\*\*3 = 1.20

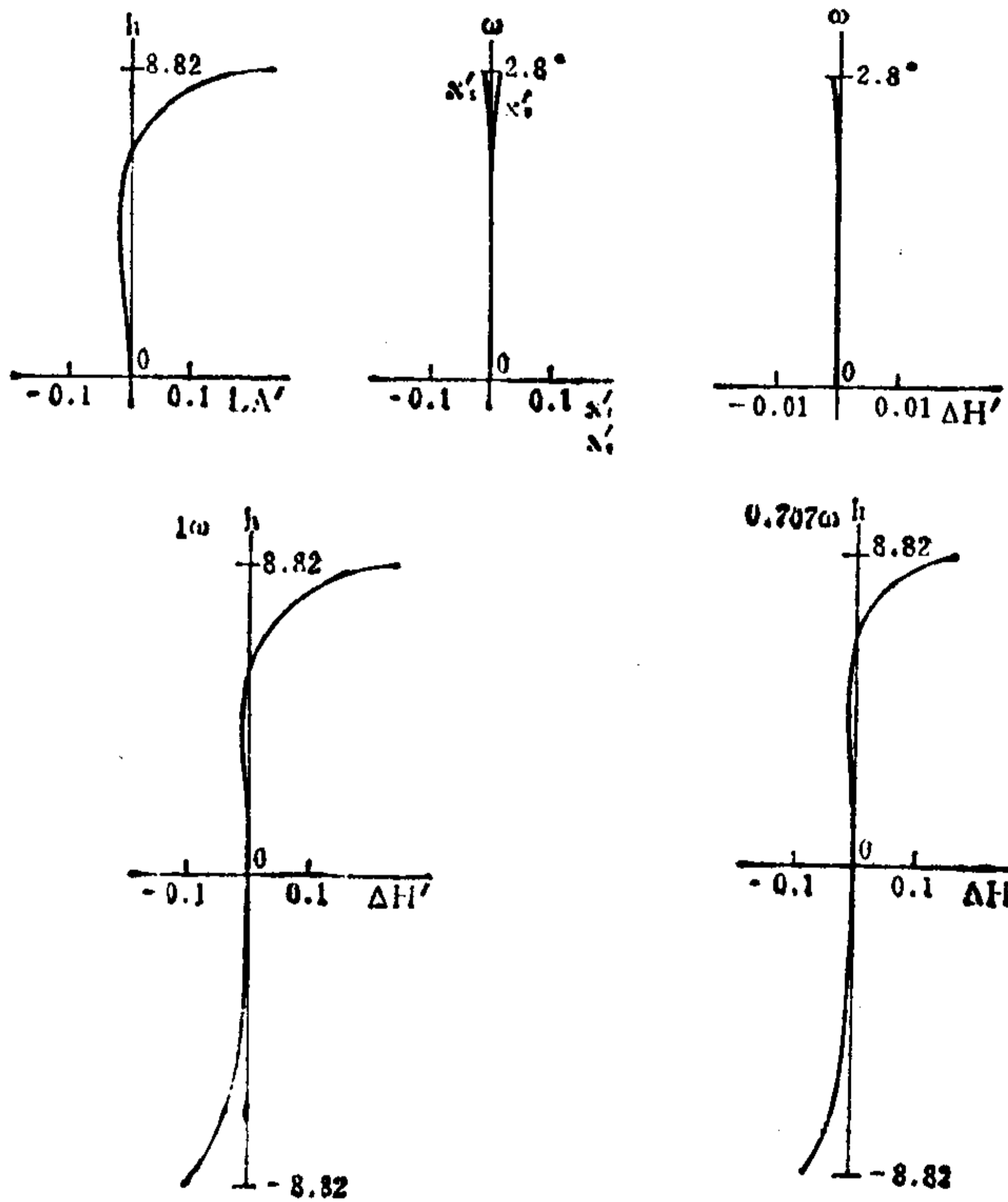

编号: 04-03-018

# 大孔径变焦距物镜

E.F.L=10.40~30.00 B.F.L=15.22 FNo.=2 F.A.=±19.3°~±6.9°

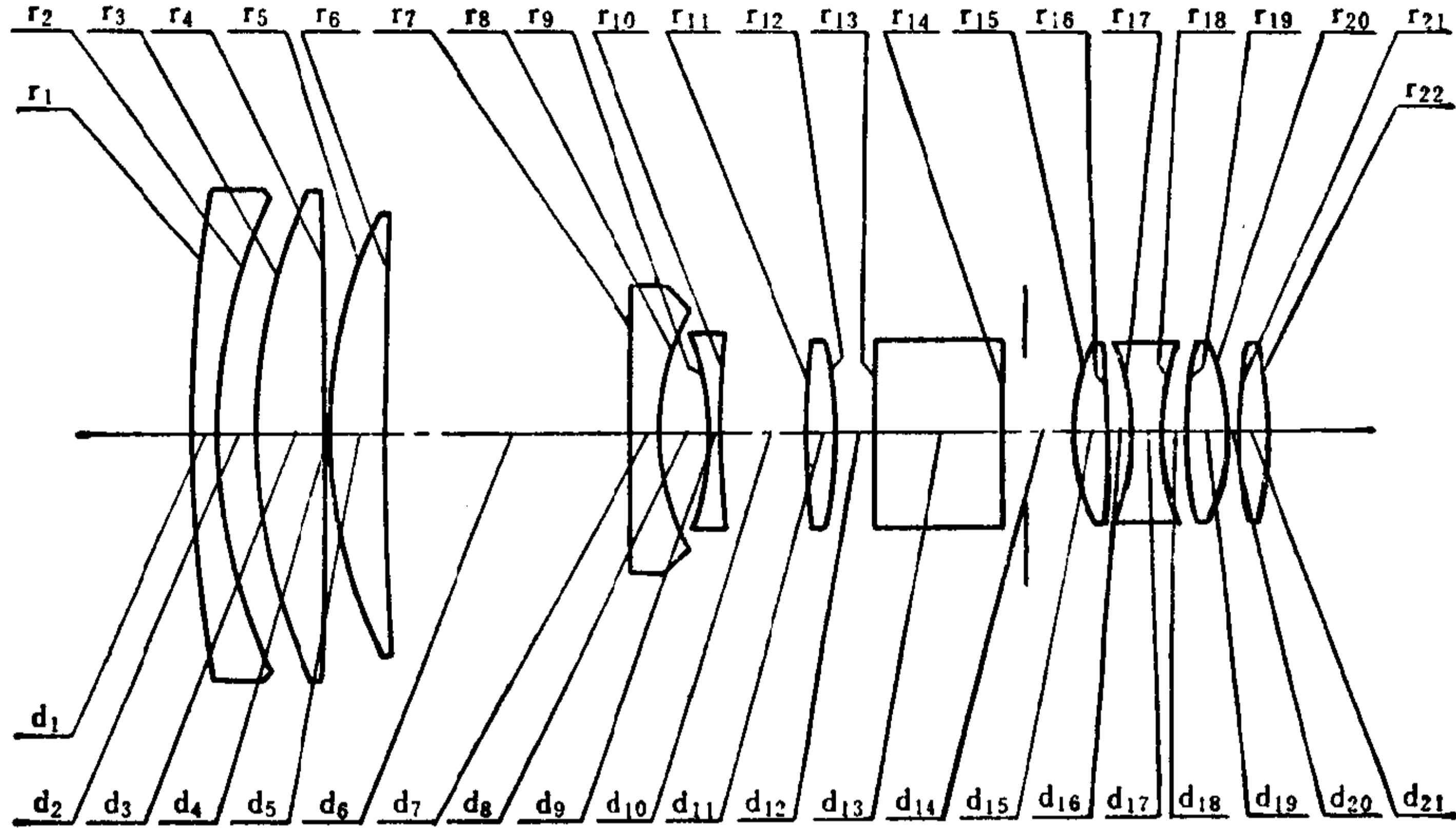

| 序号 | r       | d     | n <sub>e</sub> | v <sub>e</sub> | 序号 | r       | d     | n <sub>e</sub> | v <sub>e</sub> |
|----|---------|-------|----------------|----------------|----|---------|-------|----------------|----------------|
| 1  | 161.60  | 1.80  | 1.76167        | 27.4           | 12 | -32.02  | 2.50  |                |                |
| 2  | 38.01   | 2.50  |                |                | 13 | ∞       | 9.00  | 1.51872        | 64.0           |
| 3  | 41.27   | 4.70  | 1.60994        | 56.4           | 14 | ∞       | 4.80* |                |                |
| 4  | -550.50 | 0.10  |                |                | 15 | 14.01   | 2.30  | 1.62509        | 52.9           |
| 5  | 33.99   | 3.80  | 1.62509        | 52.9           | 16 | -190.50 | 1.80  |                |                |
| 6  | 308.20  | *** 1 |                |                | 17 | -16.81  | 2.10  | 1.79180        | 25.9           |
| 7  | 700.00  | 2.00  | 1.60548        | 60.4           | 18 | 17.94   | 1.65  |                |                |
| 8  | 17.11   | *** 2 |                |                | 19 | 45.04   | 2.60  | 1.62286        | 60.1           |
| 9  | -19.53  | 1.00  | 1.48914        | 70.2           | 20 | -15.87  | 0.80  |                |                |
| 10 | 120.02  | *** 3 |                |                | 21 | 27.81   | 2.00  | 1.62286        | 60.1           |
| 11 | 224.40  | 1.80  | 1.79180        | 25.9           | 22 | -31.06  |       |                |                |

4.80\* = 1.80 + 3.00

04-03-018-1

|                | $\Sigma S_1$ | $\Sigma S_2$ | $\Sigma S_3$ | $\Sigma S_4$ | $\Sigma S_5$  | HI        | QP(1 $\omega$ ) |
|----------------|--------------|--------------|--------------|--------------|---------------|-----------|-----------------|
|                | -0.0284      | -0.0061      | 0.0023       | -0.0171      | -0.0788       | 3.6       | -4.8%           |
| h 或 $\omega$ % | LA'          | $\Delta H'$  | $x'_t$       | $x'_s$       | $x'_t - x'_s$ | $K'_{T1}$ | $K'_{T0.7}$     |
| 100            | -0.067       | -0.176       | -0.0715      | -0.1102      | 0.0387        | 0.05397   | 0.00189         |
| 70             | -0.081       | -0.061       | -0.0393      | -0.0584      | 0.0191        | 0.03093   | -0.00116        |

E. F. L = 10.40 ( $\pm 19.3^\circ$ )

\*\*\*1 = 1.11, \*\*\*2 = 15.24, \*\*\*3 = 9.95

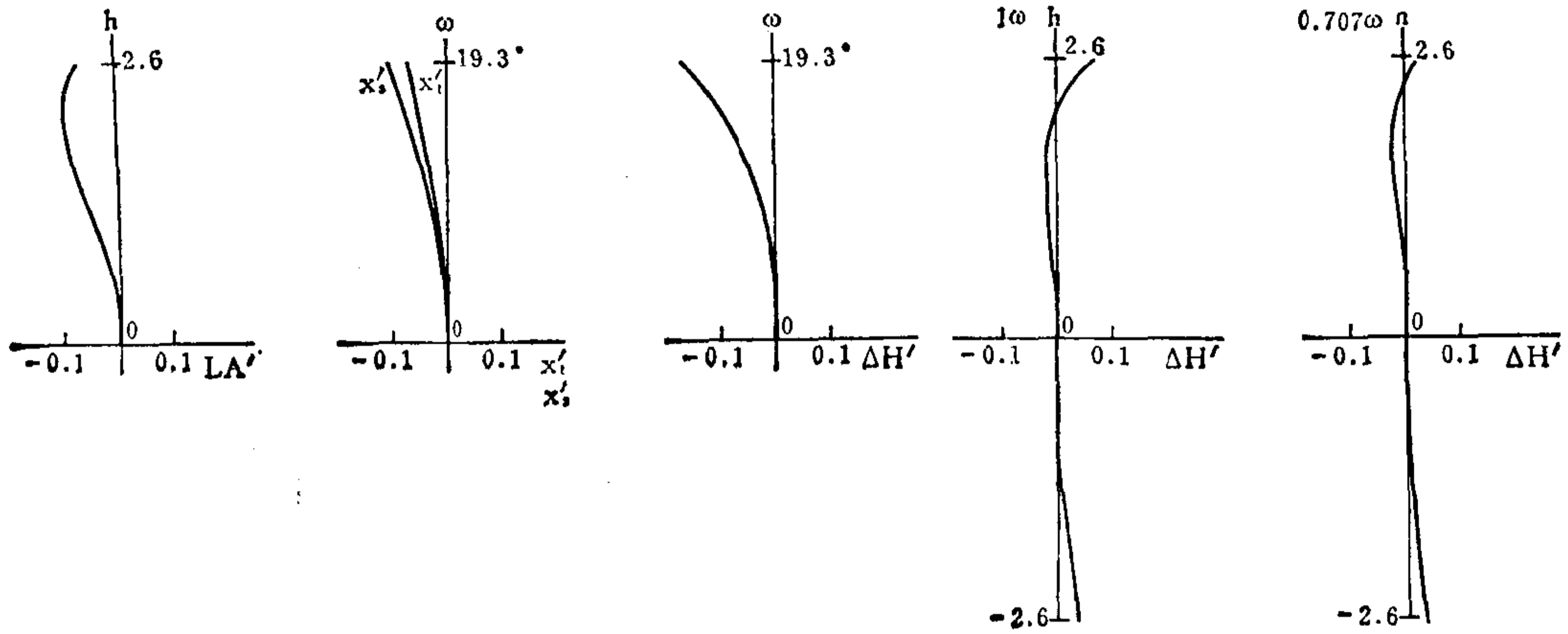

04-03-018-2

|                | $\Sigma S_1$ | $\Sigma S_2$ | $\Sigma S_3$ | $\Sigma S_4$ | $\Sigma S_5$  | HI        | QP(1 $\omega$ ) |
|----------------|--------------|--------------|--------------|--------------|---------------|-----------|-----------------|
|                | -0.02155     | -0.00188     | 0.00280      | -0.01843     | -0.02586      | 3.6       | -1.6%           |
| h 或 $\omega$ % | LA'          | $\Delta H'$  | $x'_t$       | $x'_s$       | $x'_t - x'_s$ | $K'_{T1}$ | $K'_{T0.7}$     |
| 100            | -0.012       | -0.0580      | -0.0336      | -0.1089      | 0.0753        | 0.07964   | 0.00897         |
| 70             | -0.054       | -0.0196      | -0.0304      | -0.0594      | 0.0290        | 0.04766   | 0.00516         |

E. F. L = 21.00 ( $\pm 9.7^\circ$ )

\*\*\*1 = 16.97, \*\*\*2 = 3.28, \*\*\*3 = 6.04

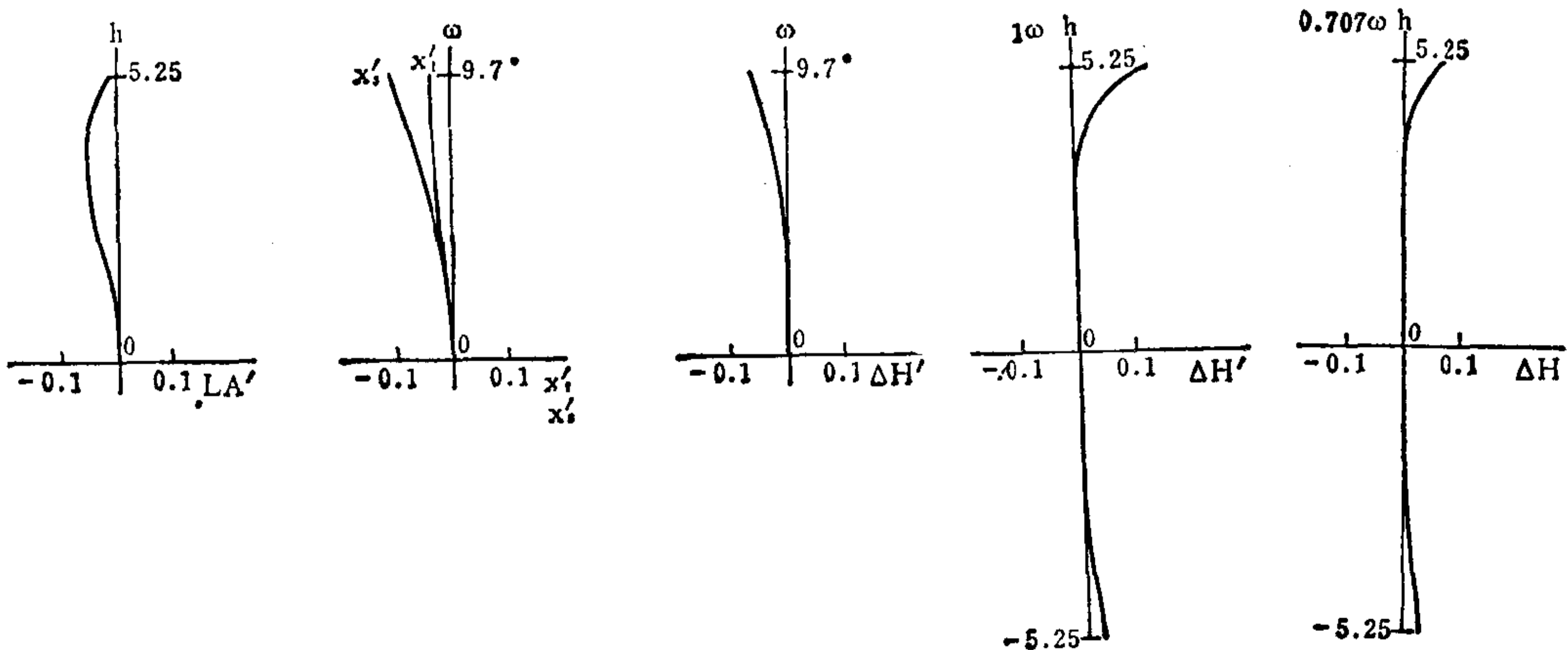

04-03-018-3

|                | $\Sigma S_1$ | $\Sigma S_2$ | $\Sigma S_3$ | $\Sigma S_4$ | $\Sigma S_5$  | HI        | QP(1 $\omega$ ) |
|----------------|--------------|--------------|--------------|--------------|---------------|-----------|-----------------|
|                | -0.01816     | 0.00137      | 0.00203      | -0.01883     | -0.00526      | 3.6       | -0.39%          |
| h 或 $\omega$ % | LA'          | $\Delta H'$  | $x'_t$       | $x'_s$       | $x'_t - x'_s$ | $K'_{T1}$ | $K'_{T0.7}$     |
| 100            | 0.0100       | -0.0141      | -0.0545      | -0.1212      | 0.0667        | 0.1000    | 0.0187          |
| 70             | -0.0411      | -0.0045      | -0.0392      | -0.0640      | 0.0248        | 0.0638    | 0.0126          |

E. F. L = 30.00 ( $\pm 6.9^\circ$ )

\*\*\*1 = 22.84; \*\*\*2 = 2.27; \*\*\*3 = 1.19

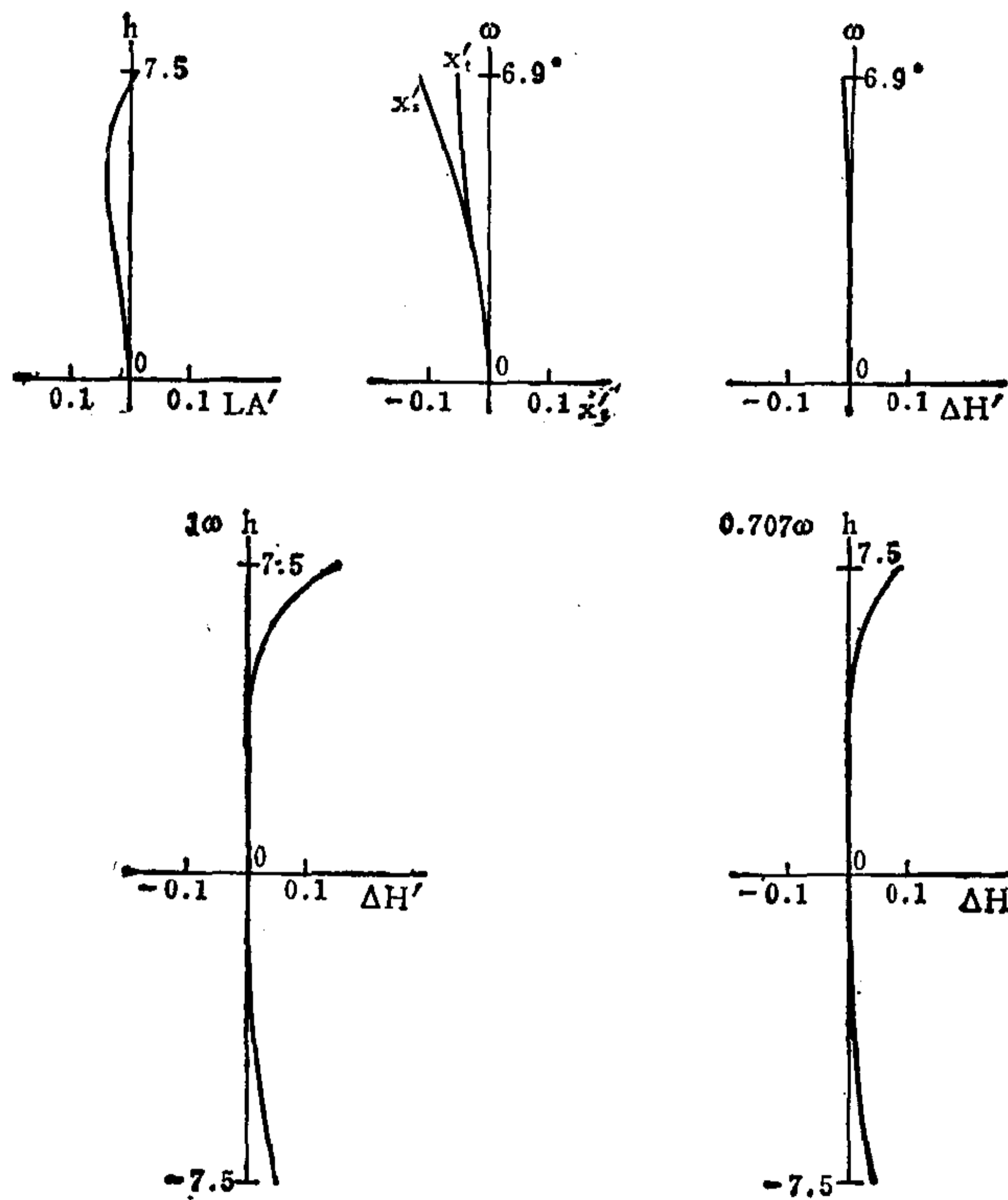

编号: 04-03-019

## 大孔径变焦距物镜

E. F. L = 9.35 ~ 35.00 B. F. L = 15.187 FNo. = 2 F. A. = ± 21.4° ~ ± 5.7°

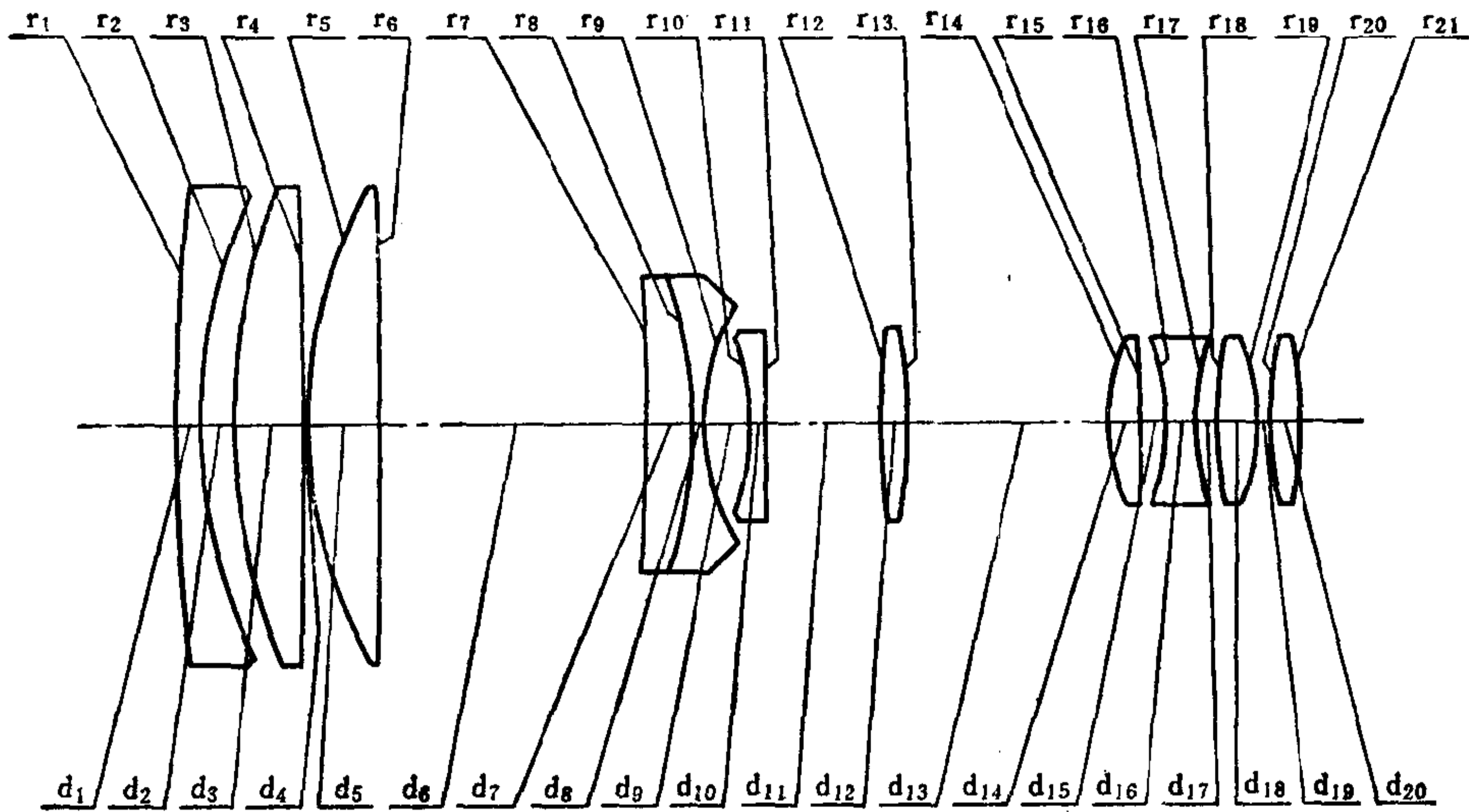

| 序号 | r        | d     | $n_e$   | $v_e$ | 序号 | r       | d      | $n_e$   | $v_e$ |
|----|----------|-------|---------|-------|----|---------|--------|---------|-------|
| 1  | 224.80   | 1.80  | 1.76167 | 27.4  | 12 | 60.13   | 1.80   | 1.69416 | 31.0  |
| 2  | 37.67    | 2.50  |         |       | 13 | -43.75  | 14.30* |         |       |
| 3  | 45.13    | 4.90  | 1.62541 | 56.6  | 14 | 14.01   | 2.30   | 1.62509 | 52.9  |
| 4  | -477.50  | 0.10  |         |       | 15 | -190.50 | 1.80   |         |       |
| 5  | 35.32    | 5.20  | 1.62509 | 52.9  | 16 | -16.81  | 2.10   | 1.79180 | 25.9  |
| 6  | -1875.00 | *** 1 |         |       | 17 | 17.94   | 1.64   |         |       |
| 7  | -286.80  | 3.10  | 1.76167 | 27.4  | 18 | 45.04   | 2.60   | 1.62286 | 60.1  |
| 8  | -31.95   | 1.00  | 1.62286 | 60.1  | 19 | -15.87  | 0.80   |         |       |
| 9  | 16.33    | *** 2 |         |       | 20 | 25.50   | 2.00   | 1.62286 | 60.1  |
| 10 | -18.55   | 1.00  | 1.52583 | 51.2  | 21 | -34.72  |        |         |       |
| 11 | 428.00   | *** 3 |         |       |    |         |        |         |       |

14.30\* = 11.30 + 3.00

04-03-019-1

|                | $\Sigma S_1$ | $\Sigma S_2$ | $\Sigma S_3$ | $\Sigma S_4$ | $\Sigma S_5$  | HI        | QP(1 $\omega$ ) |
|----------------|--------------|--------------|--------------|--------------|---------------|-----------|-----------------|
|                | -0.02864     | -0.00097     | 0.00744      | -0.01574     | -0.08294      | 3.67      | -3.9%           |
| h 或 $\omega$ % | LA'          | $\Delta H'$  | $x'_t$       | $x'_s$       | $x'_t - x'_s$ | $K'_{T1}$ | $K'_{T0.7}$     |
| 100            | -0.0569      | -0.1456      | -0.1388      | -0.0948      | -0.0440       | 0.04493   | 0.00717         |
| 70             | -0.0792      | -0.0587      | -0.0139      | -0.0419      | 0.0280        | 0.02956   | 0.00037         |

E. F. L = 9.35 ( $\pm 21.4^\circ$ )

\*\*\* 1 = 1.15; \*\*\* 2 = 17.02; \*\*\* 3 = 12.23

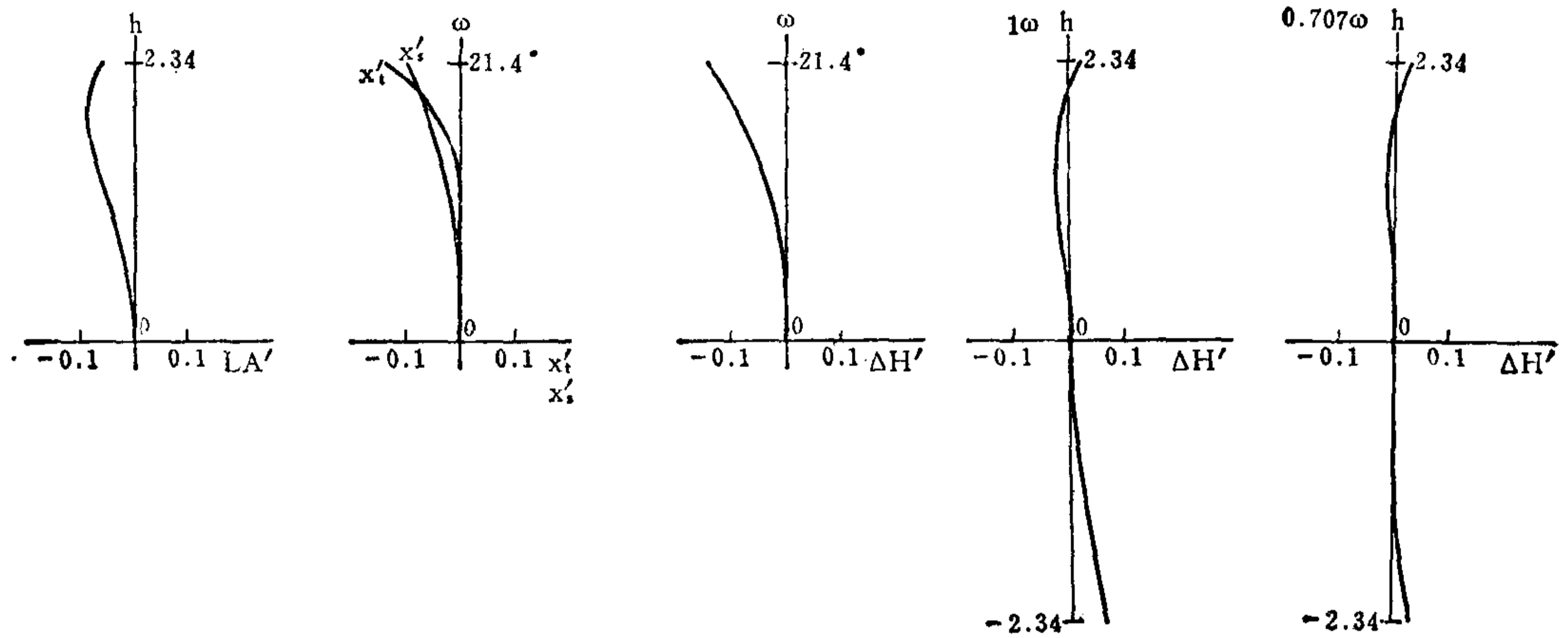

04-03-019-2

|                | $\Sigma S_1$ | $\Sigma S_2$ | $\Sigma S_3$ | $\Sigma S_4$ | $\Sigma S_5$  | HI        | QP(1 $\omega$ ) |
|----------------|--------------|--------------|--------------|--------------|---------------|-----------|-----------------|
|                | -0.02291     | -0.00077     | 0.00500      | -0.01699     | -0.02867      | 3.6       | -2.05%          |
| h 或 $\omega$ % | LA'          | $\Delta H'$  | $x'_t$       | $x'_s$       | $x'_t - x'_s$ | $K'_{T1}$ | $K'_{T0.7}$     |
| 100            | -0.0126      | -0.0739      | 0.1183       | -0.0610      | 0.1793        | 0.0713    | 0.0045          |
| 70             | -0.0566      | -0.0230      | 0.0195       | -0.0409      | 0.0604        | 0.0474    | 0.0051          |

E. F. L = 21.00 ( $\pm 9.7^\circ$ )

\*\*\* 1 = 18.93; \*\*\* 2 = 3.12; \*\*\* 3 = 8.35

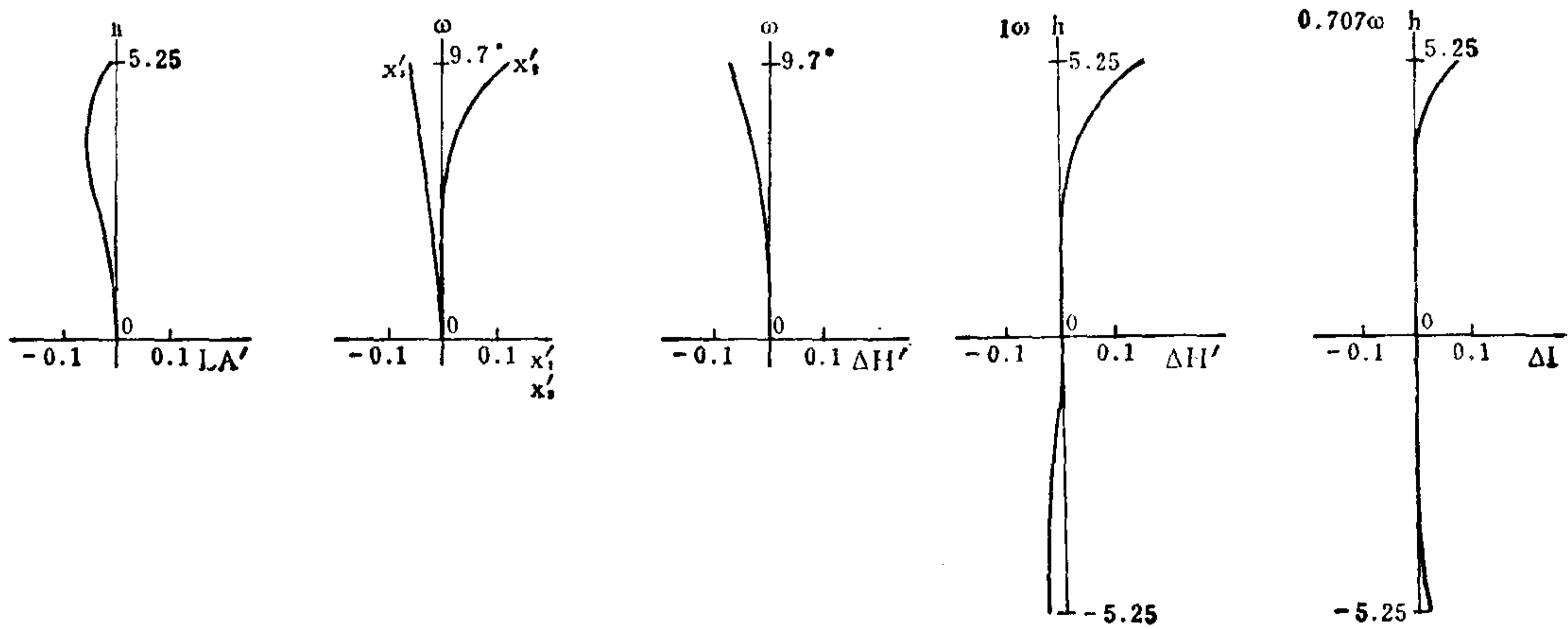

04-03-019-3

|                | $\Sigma S_1$ | $\Sigma S_2$ | $\Sigma S_3$ | $\Sigma S_4$ | $\Sigma S_5$  | HI        | QP(1 $\omega$ ) |
|----------------|--------------|--------------|--------------|--------------|---------------|-----------|-----------------|
|                | -0.02157     | 0.00520      | -0.00132     | -0.01644     | 0.00516       | 3.5       | -0.14%          |
| h 或 $\omega$ % | LA'          | $\Delta H'$  | $x'_t$       | $x'_s$       | $x'_t - x'_s$ | $K'_{T1}$ | $K'_{T0.7}$     |
| 100            | -0.0122      | -0.0051      | 0.0488       | -0.0994      | 0.1482        | 0.05953   | 0.00029         |
| 70             | -0.0533      | 0.0010       | -0.0359      | -0.0612      | 0.0253        | 0.06269   | 0.01323         |

E. F. L = 35.00 ( $\pm 5.7^\circ$ )

\*\*\* 1 = 26.36; \*\*\* 2 = 3.10; \*\*\* 3 = 0.95

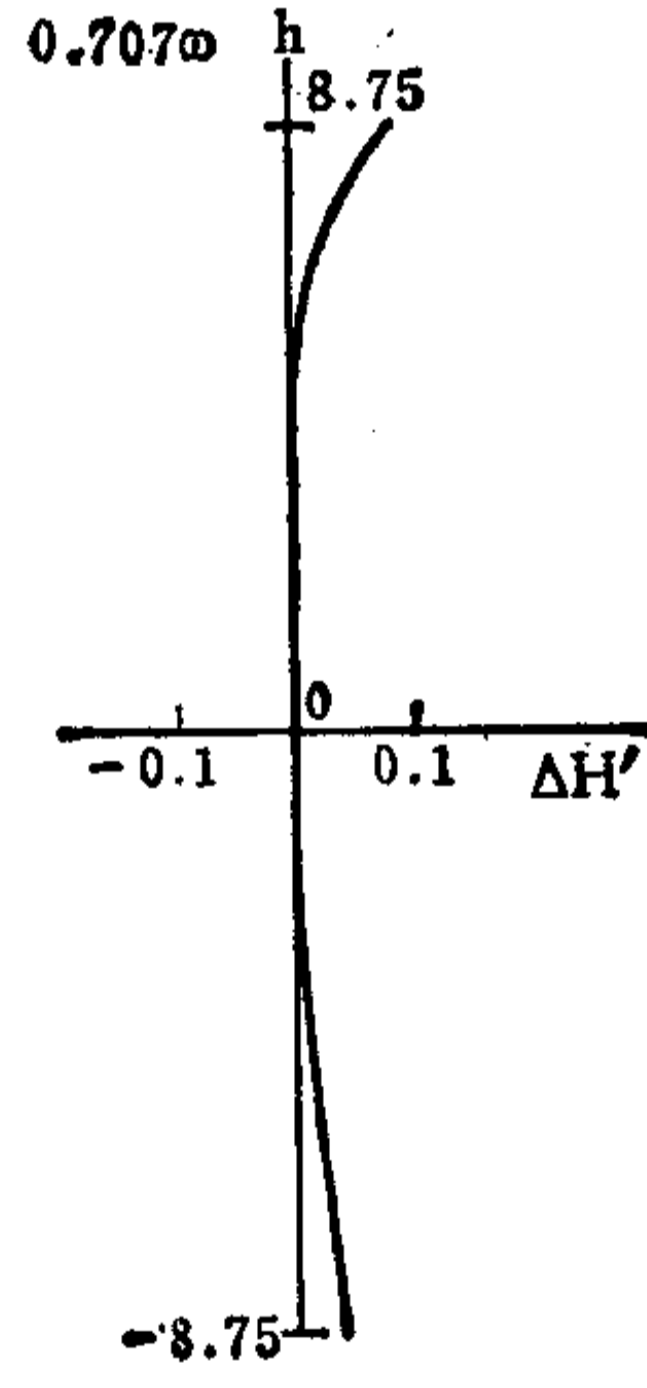
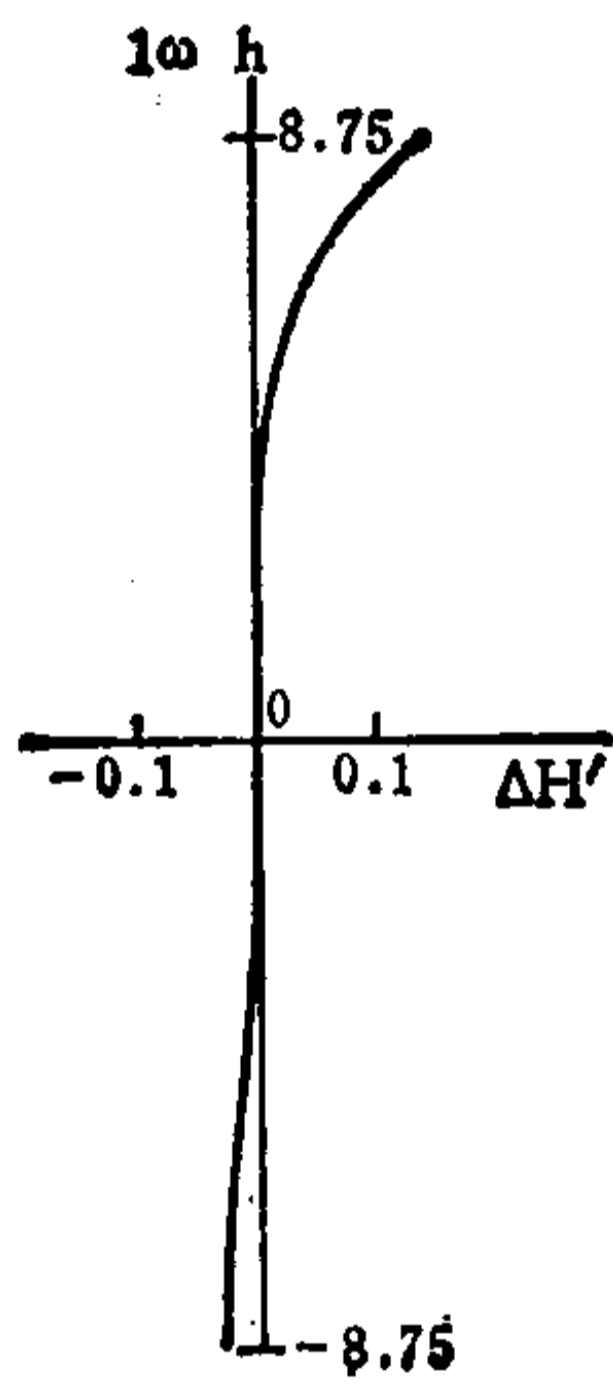
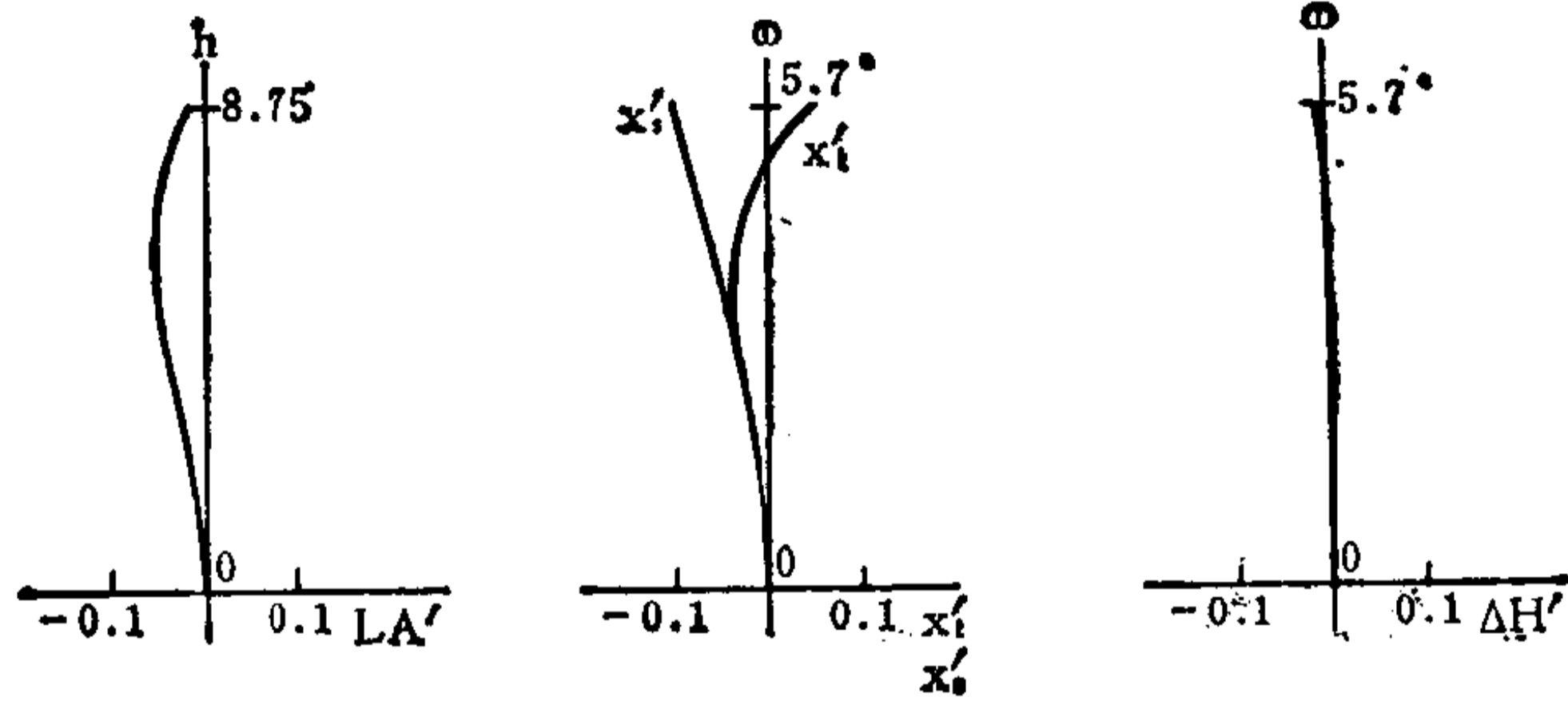

编号: 04-03-020

## 变焦距摄影物镜

E.F.L.=7.600~29.900 B.F.L=7.20 FNo.=1.8 F.A.= $\pm 22.3^\circ \sim \pm 5.7^\circ$

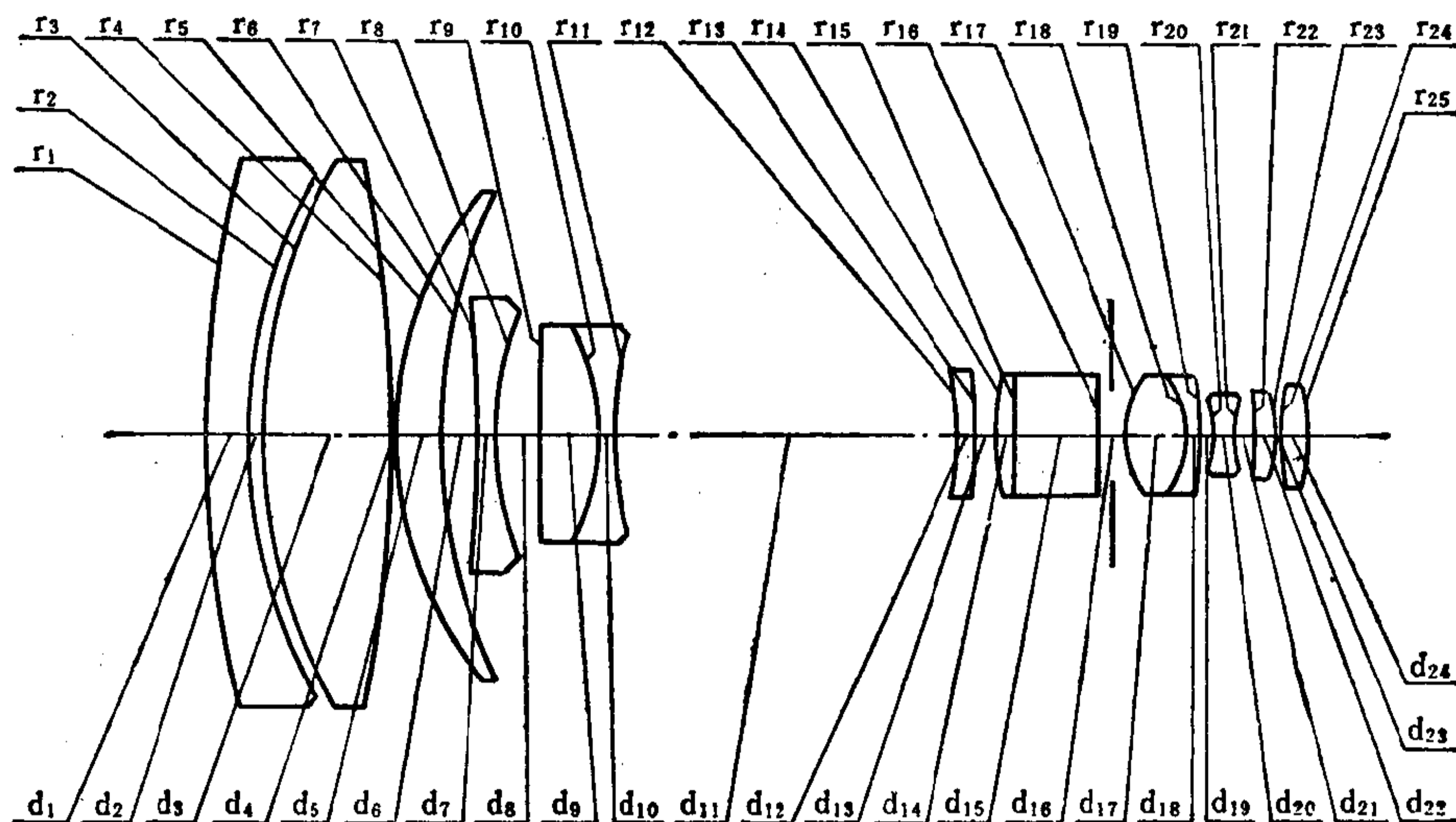

| 序号 | r         | d      | nd      | v     | 序号 | r        | d      | nd      | v     |
|----|-----------|--------|---------|-------|----|----------|--------|---------|-------|
| 1  | 80.5840   | 3.000  | 1.80518 | 25.46 | 14 | 20.6830  | 1.300  | 1.71300 | 53.89 |
| 2  | 40.6790   | 1.000  |         |       | 15 | $\infty$ | 6.400  | 1.60738 | 56.66 |
| 3  | 42.7800   | 10.000 | 1.56873 | 63.12 | 16 | $\infty$ | 2.000* |         |       |
| 4  | -97.8630  | 0.100  |         |       | 17 | 7.6076   | 4.600  | 1.71300 | 53.89 |
| 5  | 29.0050   | 3.500  | 1.61765 | 55.10 | 18 | -7.6076  | 0.700  | 1.62374 | 47.04 |
| 6  | 42.4730   | *** 1  |         |       | 19 | -32.3150 | 1.100  |         |       |
| 7  | -118.8400 | 1.510  | 1.69100 | 54.80 | 20 | -6.9780  | 1.600  | 1.80518 | 25.46 |
| 8  | 23.5440   | 3.200  |         |       | 21 | 9.3061   | 1.500  |         |       |
| 9  | 805.8400  | 4.500  | 1.74077 | 27.70 | 22 | -38.4060 | 1.700  | 1.78797 | 47.44 |
| 10 | -17.4030  | 1.200  | 1.71300 | 53.89 | 23 | -12.0570 | 0.050  |         |       |
| 11 | 29.6400   | *** 2  |         |       | 24 | 20.2410  | 2.000  | 1.78797 | 47.44 |
| 12 | -24.4050  | 1.400  | 1.78443 | 43.77 | 25 | -20.8330 |        |         |       |
| 13 | -63.0790  | *** 3  |         |       |    |          |        |         |       |

2.000\* = 1.000 + 1.000



04-03-020-1

|                | $\Sigma S_1$ | $\Sigma S_2$ | $\Sigma S_3$ | $\Sigma S_4$ | $\Sigma S_5$  | HI       | QP(1 $\omega$ ) |
|----------------|--------------|--------------|--------------|--------------|---------------|----------|-----------------|
|                | -0.03873     | -0.00681     | 0.00887      | -0.00865     | -0.06420      | 3.1      | -2.8%           |
| h 或 $\omega$ % | LA'          | $\Delta H'$  | $x'_t$       | $x'_s$       | $x'_t - x'_s$ | $K_{T1}$ | $K_{T0.7}$      |
| 100            | 0.3342       | -0.0882      | 0.0055       | -0.0131      | 0.0186        | 0.2023   | 0.0010          |
| 70             | -0.0021      | -0.0385      | 0.0103       | -0.0117      | 0.0220        | 0.2355   | 0.0087          |

E. F. L = 7.600 ( $\pm 22.3^\circ$ )

\*\*\* 1 = 2.510; \*\*\* 2 = 25.813; \*\*\* 3 = 1.500

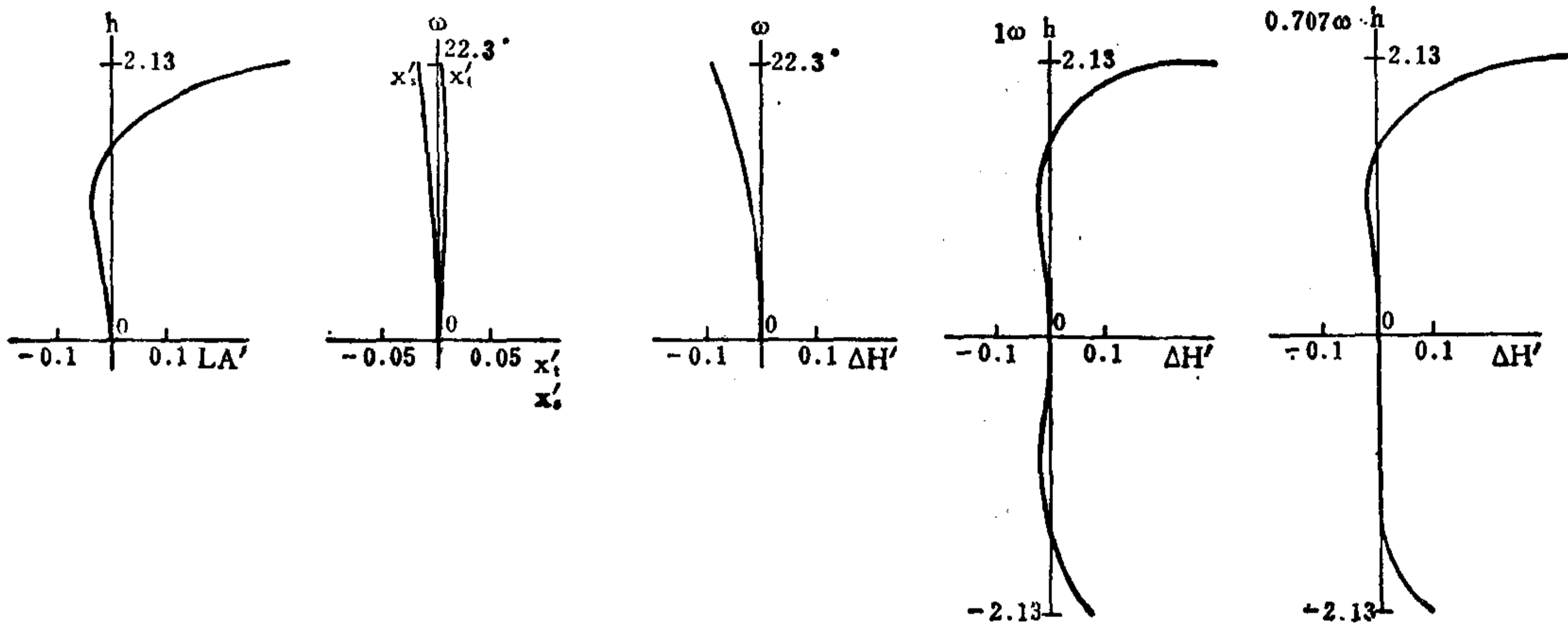

04-03-020-2

|                | $\Sigma S_1$ | $\Sigma S_2$ | $\Sigma S_3$ | $\Sigma S_4$ | $\Sigma S_5$  | HI       | QP(1 $\omega$ ) |
|----------------|--------------|--------------|--------------|--------------|---------------|----------|-----------------|
|                | -0.03327     | -0.00224     | 0.00776      | -0.00892     | 0.02084       | 3        | 3.1%            |
| h 或 $\omega$ % | LA'          | $\Delta H'$  | $x'_t$       | $x'_s$       | $x'_t - x'_s$ | $K_{T1}$ | $K_{T0.7}$      |
| 100            | 0.3689       | 0.0932       | -0.0358      | -0.0216      | -0.0142       | 0.2542   | 0.0078          |
| 70             | 0.0145       | 0.0221       | -0.0020      | -0.0151      | 0.0131        | 0.2638   | 0.0148          |

E. F. L = 17.500 ( $\pm 9.7^\circ$ )

\*\*\* 1 = 19.328; \*\*\* 2 = 8.995; \*\*\* 3 = 3.500

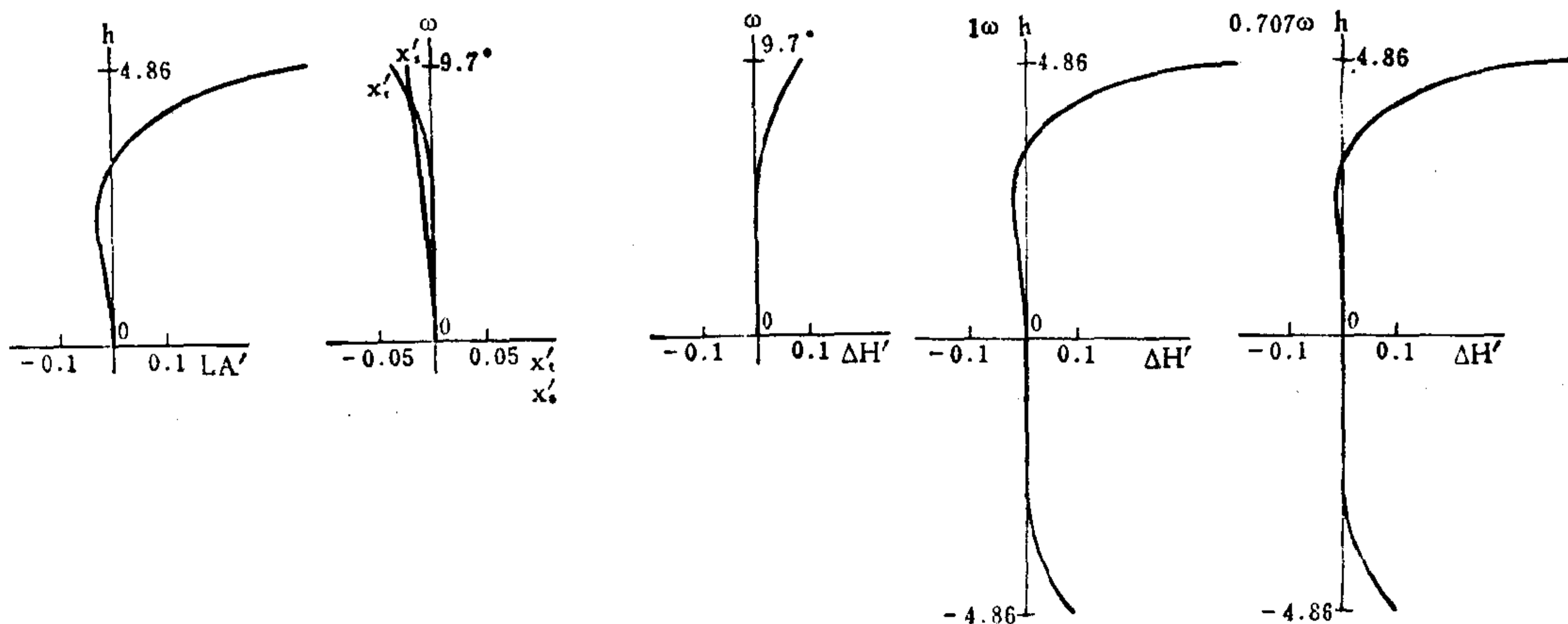

04-03-020-3

|                | $\Sigma S_1$ | $\Sigma S_2$ | $\Sigma S_3$ | $\Sigma S_4$ | $\Sigma S_5$  | HI       | QP(1 $\omega$ ) |
|----------------|--------------|--------------|--------------|--------------|---------------|----------|-----------------|
|                | -0.02390     | -0.00318     | 0.00228      | -0.00906     | 0.04645       | 3        | 3.4%            |
| h 或 $\omega$ % | LA'          | $\Delta H'$  | $x'_t$       | $x'_s$       | $x'_t - x'_s$ | $K_{T1}$ | $K_{T0.7}$      |
| 100            | 0.3985       | 0.1021       | 0.0391       | -0.0187      | 0.0578        | 0.3763   | 0.0166          |
| 70             | 0.0291       | 0.0324       | -0.0013      | -0.0182      | 0.0169        | 0.2876   | 0.0229          |

E. F. L = 29.900 ( $\pm 5.7^\circ$ )

\*\*\* 1 = 26.219; \*\*\* 2 = 2.105; \*\*\* 3 = 1.500

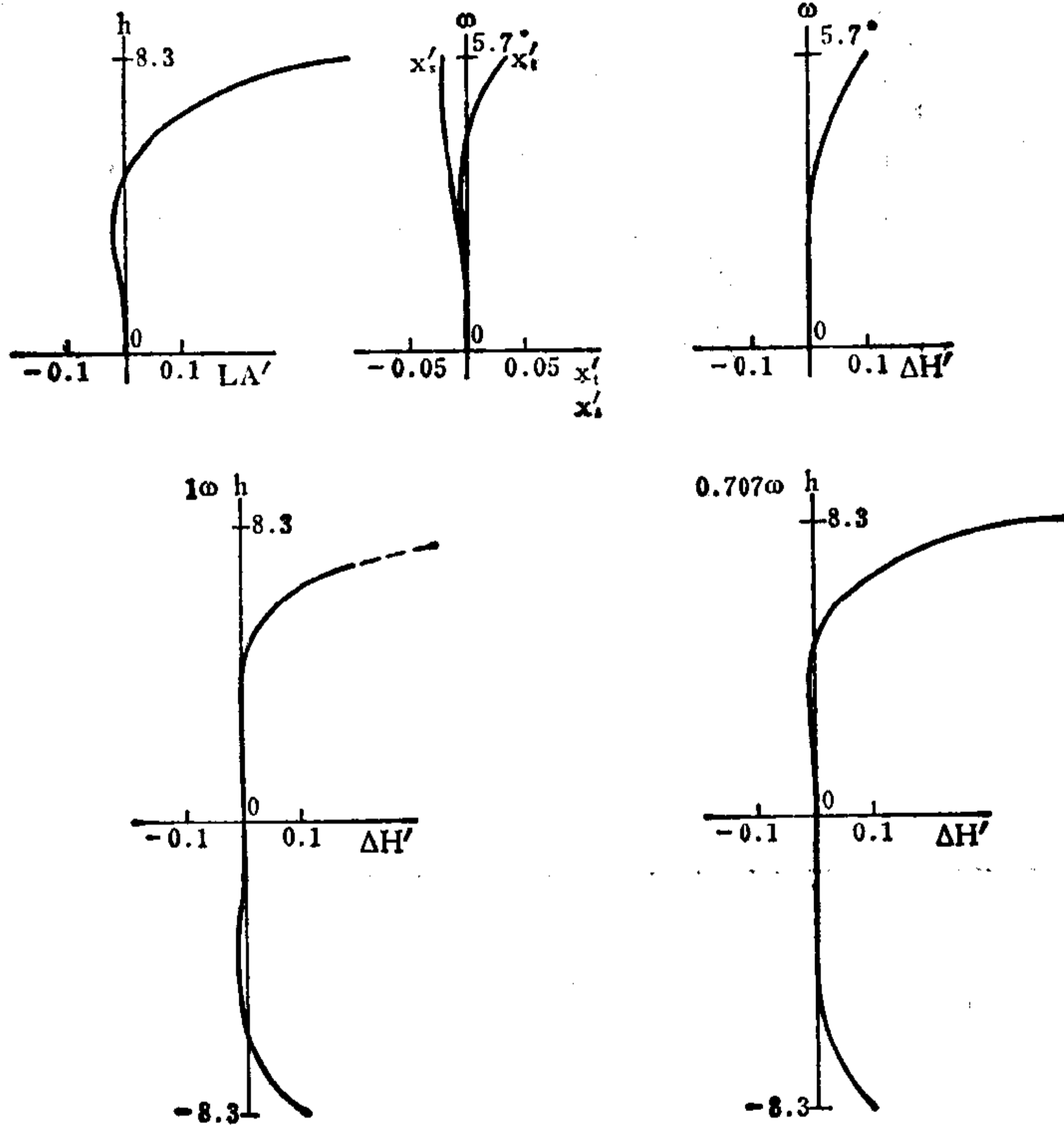

编号: 04-03-021

# 变 焦 距 镜 头

E. F. L = 1.0000 ~ 4.4444    B. F. L = 1.4842    FNo. = 2.5    F. A. =  $\pm 27.5^\circ \sim \pm 6.2^\circ$

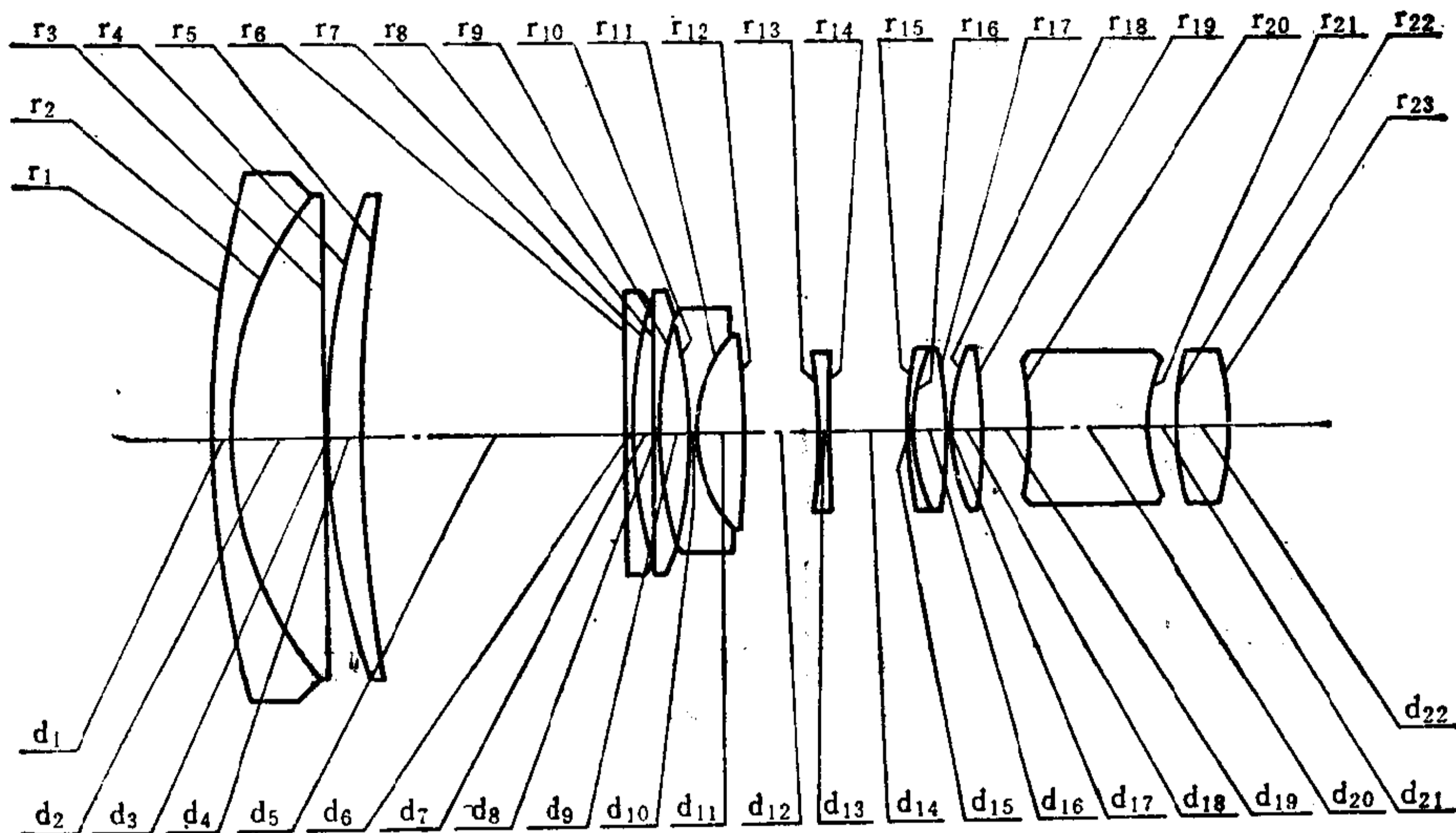

| 序号 | r        | d      | n <sub>d</sub> | v    | 序号 | r        | d       | n <sub>d</sub> | v    |
|----|----------|--------|----------------|------|----|----------|---------|----------------|------|
| 1  | 4.6924   | 0.0667 | 1.6889         | 31.1 | 13 | -3.0782  | 0.0444  | 1.5688         | 56.0 |
| 2  | 1.7478   | 0.4444 | 1.6935         | 53.4 | 14 | 9.6259   | *** 3   |                |      |
| 3  | ∞        | 0.0022 |                |      | 15 | 2.4029   | 0.0222  | 1.7283         | 28.3 |
| 4  | 3.3395   | 0.1556 | 1.6204         | 60.3 | 16 | 0.9098   | 0.1378  | 1.6433         | 47.8 |
| 5  | 9.0175   | *** 1  |                |      | 17 | -2.4029  | 0.0111  |                |      |
| 6  | ∞        | 0.0400 | 1.6385         | 55.5 | 18 | 0.9524   | 0.1442  | 1.6073         | 59.5 |
| 7  | 2.0666   | 0.0751 |                |      | 19 | -13.4843 | 0.2307* |                |      |
| 8  | ∞        | 0.0400 | 1.6385         | 55.5 | 20 | -1.6858  | 0.5509  | 1.6477         | 33.9 |
| 9  | 2.0666   | 0.1316 |                |      | 21 | 0.7678   | 0.1164  |                |      |
| 10 | -2.0666  | 0.0267 | 1.6583         | 57.3 | 22 | 1.3423   | 0.2444  | 1.6237         | 47.0 |
| 11 | 0.6651   | 0.2289 | 1.6477         | 33.9 | 23 | -1.3423  |         |                |      |
| 12 | -10.1419 | *** 2  |                |      |    |          |         |                |      |

0.2307\* = 0.1000 + 0.1307

04-03-021-1

|                | $\Sigma S_1$ | $\Sigma S_2$ | $\Sigma S_3$ | $\Sigma S_4$ | $\Sigma S_5$  | HI        | QP(1 $\omega$ ) |
|----------------|--------------|--------------|--------------|--------------|---------------|-----------|-----------------|
|                | -0.00328     | -0.00247     | -0.00174     | -0.00022     | -0.01774      | 0.52      | -10.4%          |
| h 或 $\omega$ % | LA'          | $\Delta H'$  | $x'_t$       | $x'_s$       | $x'_t - x'_s$ | $K'_{T1}$ | $K'_{T0.7}$     |
| 100            | 0.03217      | -0.05414     | 0.01183      | 0.00236      | 0.00947       | -0.05289  | -0.00106        |
| 70             | -0.00691     | -0.01774     | -0.00258     | -0.00163     | -0.00095      | 0.00482   | -0.00135        |

E. F. L = 1.0000 ( $\pm 27.5^\circ$ )

\*\*\* 1 = 0.0097; \*\*\* 2 = 1.8414; \*\*\* 3 = 0.0889

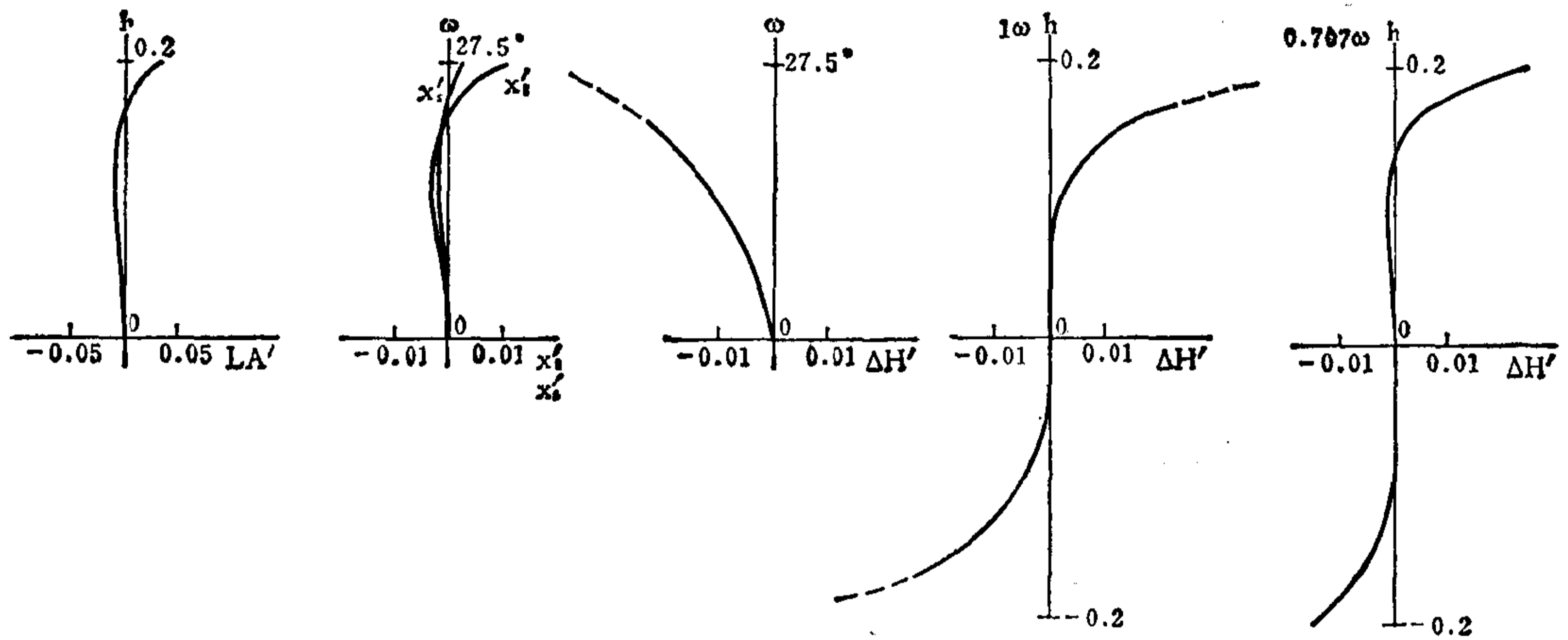

04-03-021-2

|                | $\Sigma S_1$ | $\Sigma S_2$ | $\Sigma S_3$ | $\Sigma S_4$ | $\Sigma S_5$  | HI        | QP(1 $\omega$ ) |
|----------------|--------------|--------------|--------------|--------------|---------------|-----------|-----------------|
|                | -0.003257    | -0.000873    | 0.000619     | -0.000235    | 0.003226      | 0.48      | 2.6%            |
| h 或 $\omega$ % | LA'          | $\Delta H'$  | $x'_t$       | $x'_s$       | $x'_t - x'_s$ | $K'_{T1}$ | $K'_{T0.7}$     |
| 100            | 0.03630      | 0.01279      | 0.001145     | 0.005608     | -0.004463     | 0.01486   | 0.00195         |
| 70             | -0.00602     | 0.00366      | 0.002030     | 0.001010     | 0.001020      | 0.00366   | -0.00124        |

E. F. L = 2.3876 ( $\pm 11.5^\circ$ )

\*\*\* 1 = 1.2155; \*\*\* 2 = 0.3521; \*\*\* 3 = 0.3724

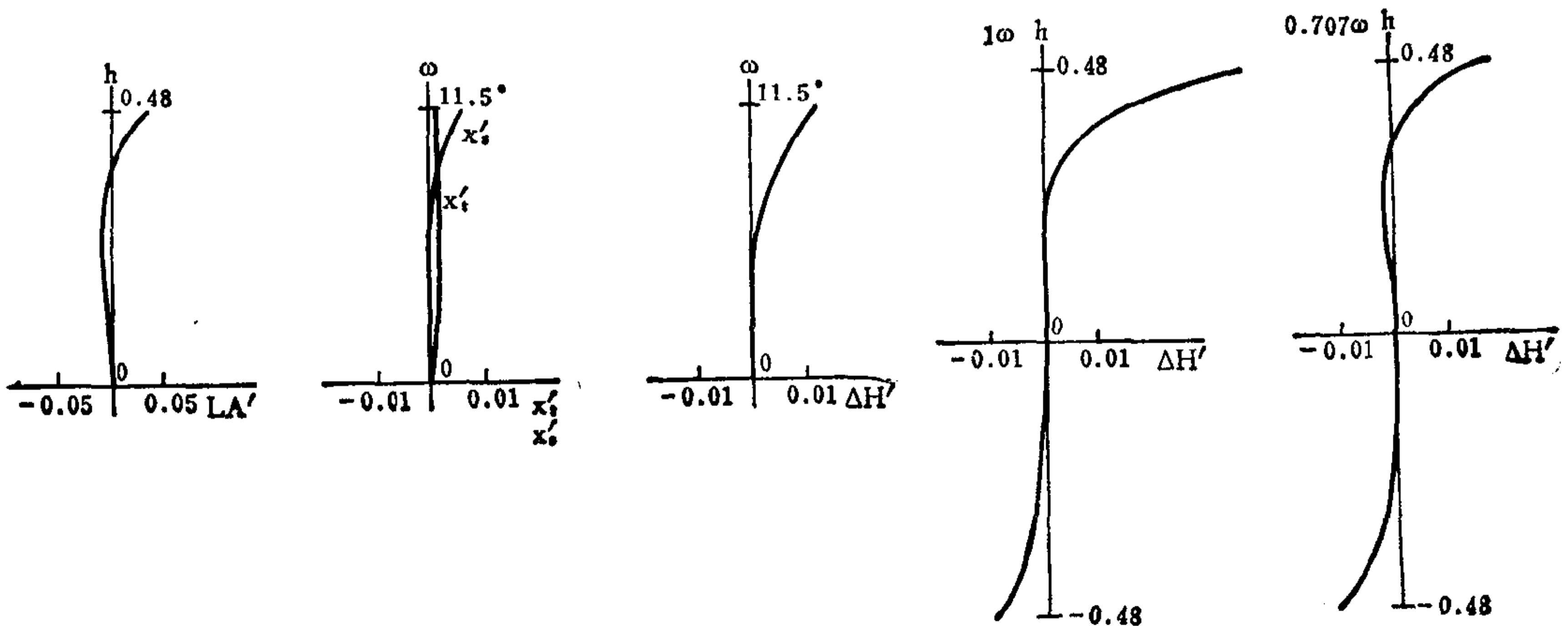

04-03-021-3

|                | $\Sigma S_1$ | $\Sigma S_2$ | $\Sigma S_3$ | $\Sigma S_4$ | $\Sigma S_5$  | HI       | QP(1 $\omega$ ) |
|----------------|--------------|--------------|--------------|--------------|---------------|----------|-----------------|
|                | -0.002405    | -0.000293    | 0.000189     | -0.000235    | 0.008252      | 0.48     | 5.2%            |
| h 或 $\omega$ % | LA'          | $\Delta H'$  | $x'_t$       | $x'_s$       | $x'_t - x'_s$ | $K_{T1}$ | $K_{T0.7}$      |
| 100            | 0.04979      | 0.0254       | -0.02395     | 0.00039      | -0.02434      | 0.03737  | 0.01105         |
| 70             | -0.00014     | 0.0080       | -0.00310     | -0.00023     | -0.00287      | 0.01318  | 0.00304         |

E. F. L = 4.4444 ( $\pm 6.2^\circ$ )

\*\*\* 1 = 1.7875; \*\*\* 2 = 0.0637; \*\*\* 3 = 0.0889

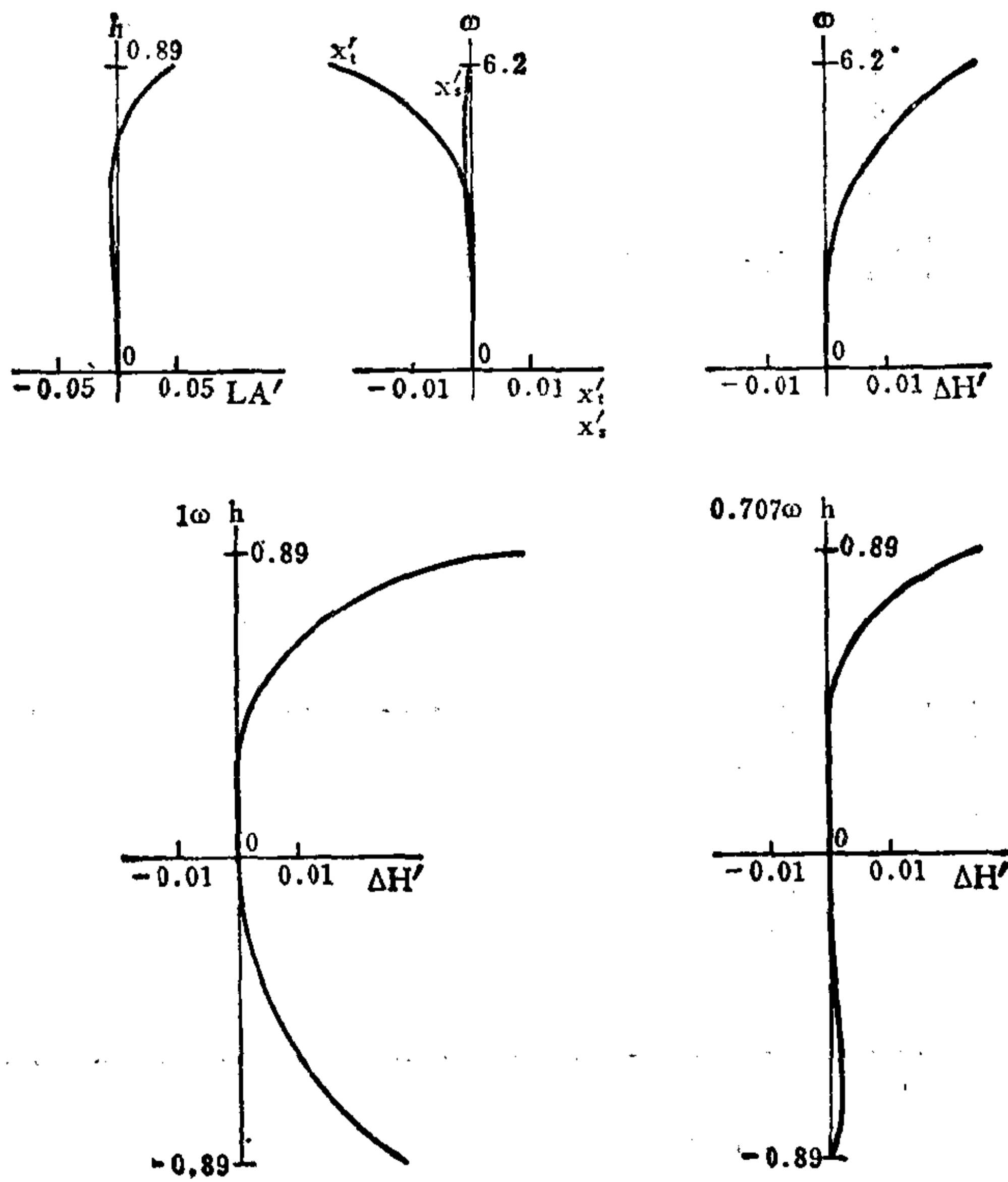

编号: 04-03-022

# 变 焦 距 镜 头

E.F.L=0.3250~1.2770 B.F.L=0.4298 FNo.=1.8 F.A.=±17.6°~±4.5°

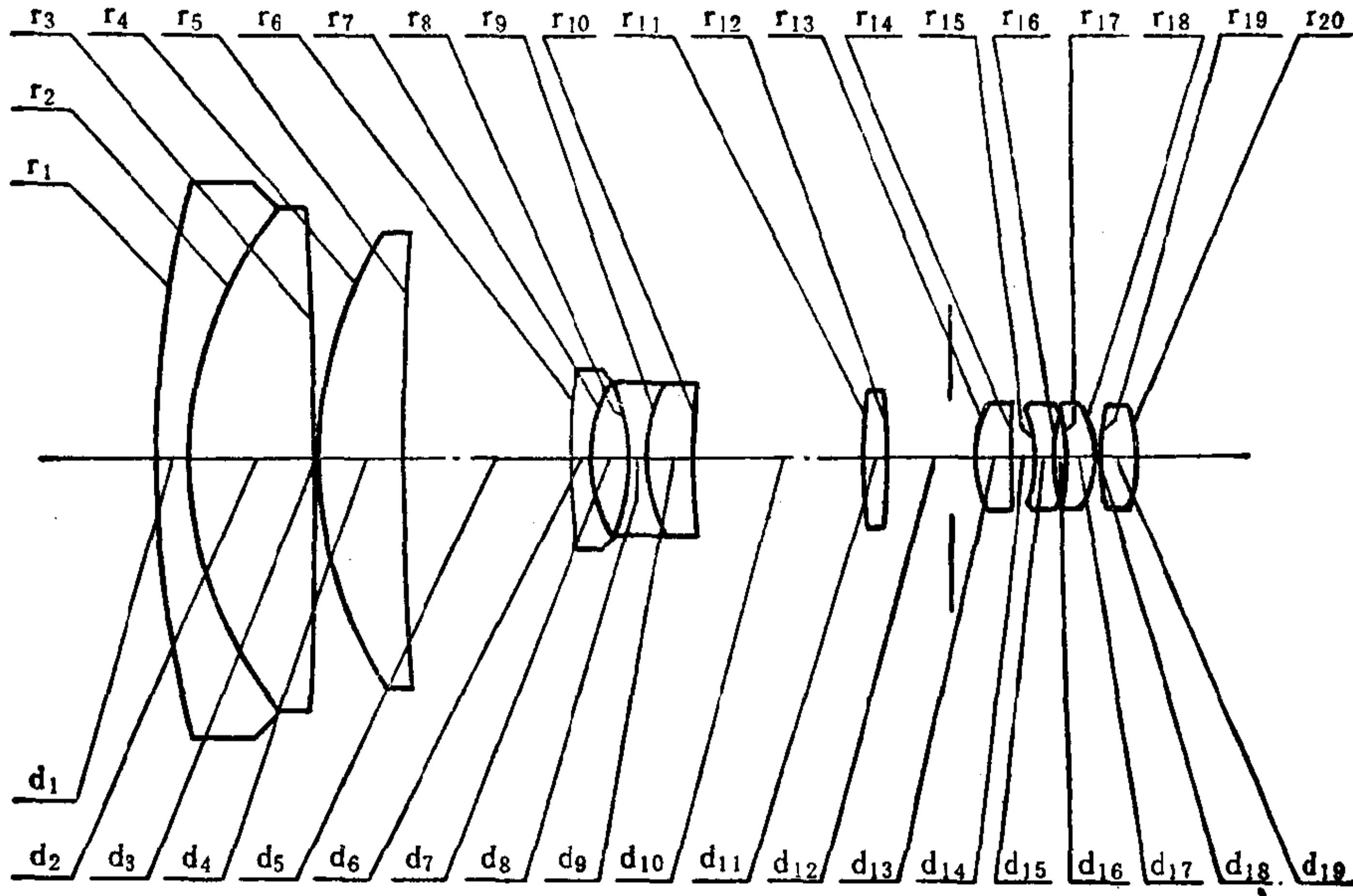

| 序号 | r        | d     | n <sub>D</sub> | v    | 序号 | r       | d      | n <sub>D</sub> | v    |
|----|----------|-------|----------------|------|----|---------|--------|----------------|------|
| 1  | 3.6500   | 0.100 | 1.751          | 27.7 | 11 | 1.8000  | 0.085  | 1.620          | 60.3 |
| 2  | 1.3100   | 0.425 | 1.620          | 60.3 | 12 | -2.8250 | 0.280* |                |      |
| 3  | -15.4000 | 0.005 |                |      | 13 | 0.3900  | 0.126  | 1.697          | 56.2 |
| 4  | 1.4650   | 0.270 | 1.620          | 60.3 | 14 | ∞       | 0.080  |                |      |
| 5  | 16.7000  | *** 1 |                |      | 15 | -0.4600 | 0.050  | 1.751          | 27.7 |
| 6  | 5.0484   | 0.060 | 1.617          | 55.0 | 16 | 0.4600  | 0.042  |                |      |
| 7  | 0.5060   | 0.120 |                |      | 17 | -0.9290 | 0.105  | 1.651          | 55.8 |
| 8  | -0.6740  | 0.055 | 1.620          | 60.3 | 18 | -0.3720 | 0.007  |                |      |
| 9  | 0.5680   | 0.150 | 1.751          | 27.7 | 19 | 0.7019  | 0.120  | 1.620          | 60.3 |
| 10 | 10.7610  | *** 2 |                |      | 20 | -0.7019 |        |                |      |

0.280\* = 0.200 + 0.080

04-03-022-1

|                | $\Sigma S_1$ | $\Sigma S_2$ | $\Sigma S_3$ | $\Sigma S_4$ | $\Sigma S_5$  | HI        | QP(1 $\omega$ ) |
|----------------|--------------|--------------|--------------|--------------|---------------|-----------|-----------------|
|                | -0.002052    | -0.000685    | 0.000041     | -0.000298    | -0.001243     | 0.10      | -2.67%          |
| h 或 $\omega$ % | LA'          | $\Delta H'$  | $x'_t$       | $x'_s$       | $x'_t - x'_s$ | $K'_{T1}$ | $K'_{T0.7}$     |
| 100            | 0.00037      | -0.00275     | -0.00150     | -0.00166     | 0.00016       | 0.00414   | -0.00035        |
| 70             | -0.00417     | -0.00089     | -0.00097     | -0.00094     | -0.00003      | 0.00239   | -0.00045        |

E. F. L = 0.3250 ( $\pm 17.6^\circ$ )

\*\*\* 1 = 0.0500; \*\*\* 2 = 0.8089

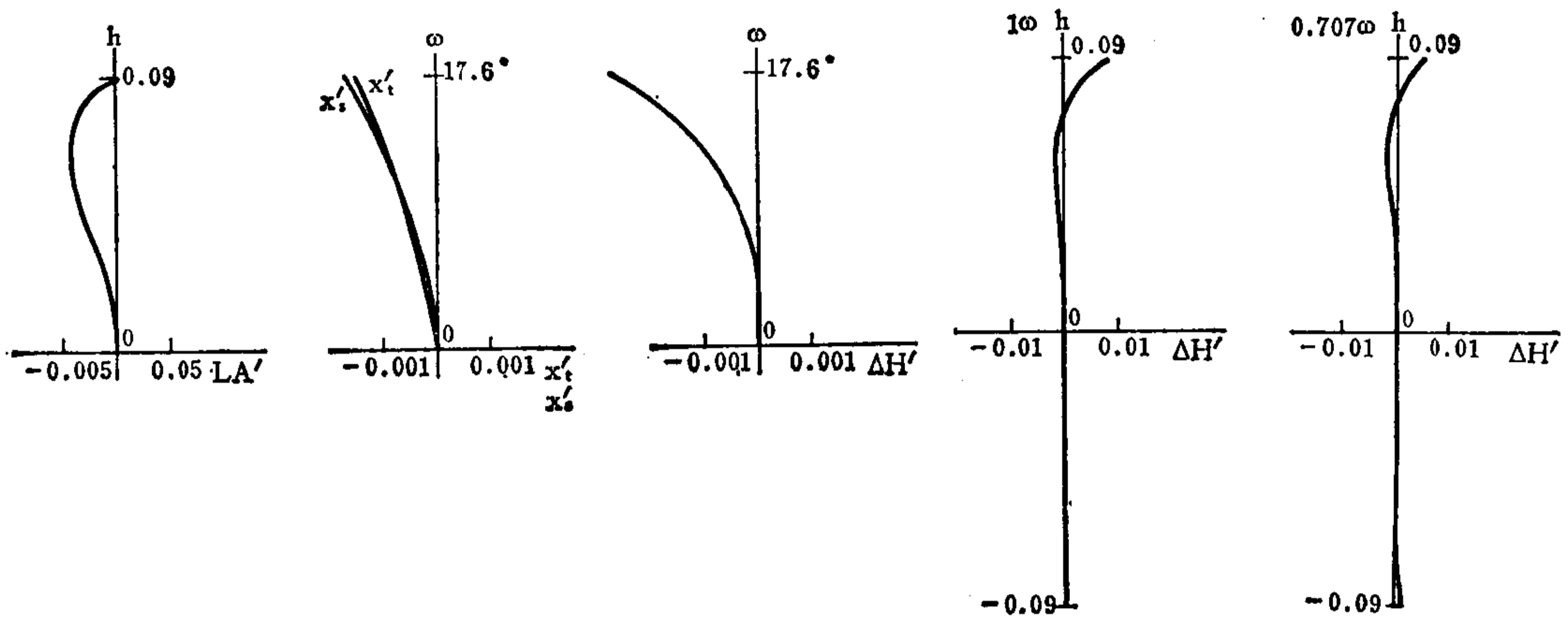

04-03-022-2

|                | $\Sigma S_1$ | $\Sigma S_2$ | $\Sigma S_3$ | $\Sigma S_4$ | $\Sigma S_5$  | HI        | QP(1 $\omega$ ) |
|----------------|--------------|--------------|--------------|--------------|---------------|-----------|-----------------|
|                | -0.002100    | -0.000303    | 0.000287     | -0.000310    | 0.001004      | 0.1       | 2.24%           |
| h 或 $\omega$ % | LA'          | $\Delta H'$  | $x'_t$       | $x'_s$       | $x'_t - x'_s$ | $K'_{T1}$ | $K'_{T0.7}$     |
| 100            | 0.00095      | 0.00225      | -0.00017     | -0.00124     | 0.00107       | 0.00288   | -0.00049        |
| 70             | -0.00411     | 0.00073      | -0.00034     | -0.00074     | 0.00040       | 0.00224   | -0.00046        |

E. F. L = 0.6440 ( $\pm 8.9^\circ$ )

\*\*\* 1 = 0.5550; \*\*\* 2 = 0.5547

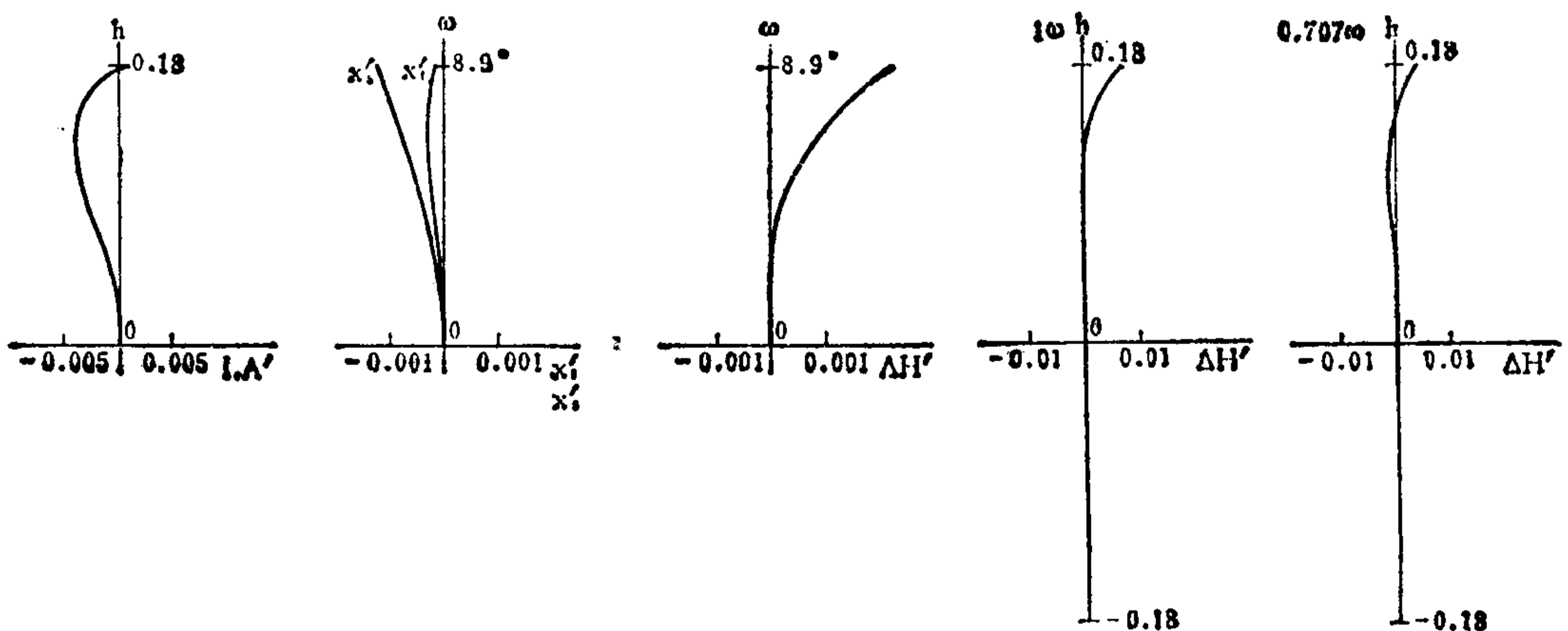

04-03-022-3

|                | $\Sigma S_1$ | $\Sigma S_2$ | $\Sigma S_3$ | $\Sigma S_4$ | $\Sigma S_5$  | HI        | QP(1 $\omega$ ) |
|----------------|--------------|--------------|--------------|--------------|---------------|-----------|-----------------|
|                | -0.002045    | -0.000477    | -0.000045    | -0.000306    | 0.001528      | 0.1       | 3.01%           |
| h 或 $\omega$ % | LA'          | $\Delta H'$  | $x_t$        | $x'_s$       | $x'_t - x'_s$ | $K'_{T1}$ | $K'_{T0.7}$     |
| 100            | -0.00009     | 0.00300      | -0.00450     | -0.00253     | -0.00197      | 0.00347   | -0.00027        |
| 70             | -0.00423     | 0.00100      | -0.00213     | -0.00131     | -0.00082      | 0.00265   | -0.00024        |

E. F. L = 1.2770 ( $\pm 4.5^\circ$ )

\*\*\* 1 = 0.8100; \*\*\* 2 = 0.0503

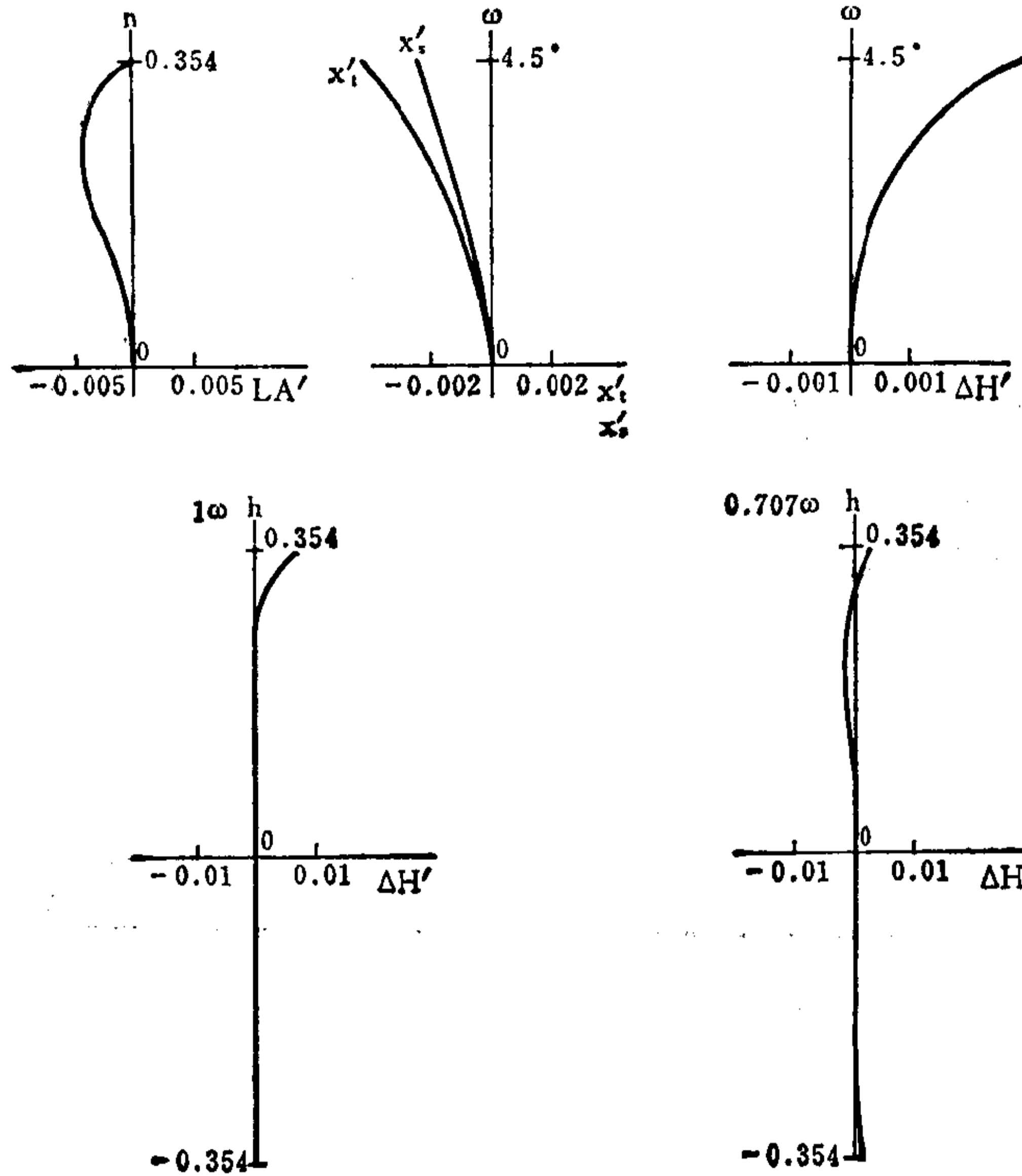



编号: 04-03-023

# 变 焦 距 镜 头

E.F.L=9.0~30.0 B.F.L=7.909 FNo.=2.8 F.A.=±22.3°~±6.7°

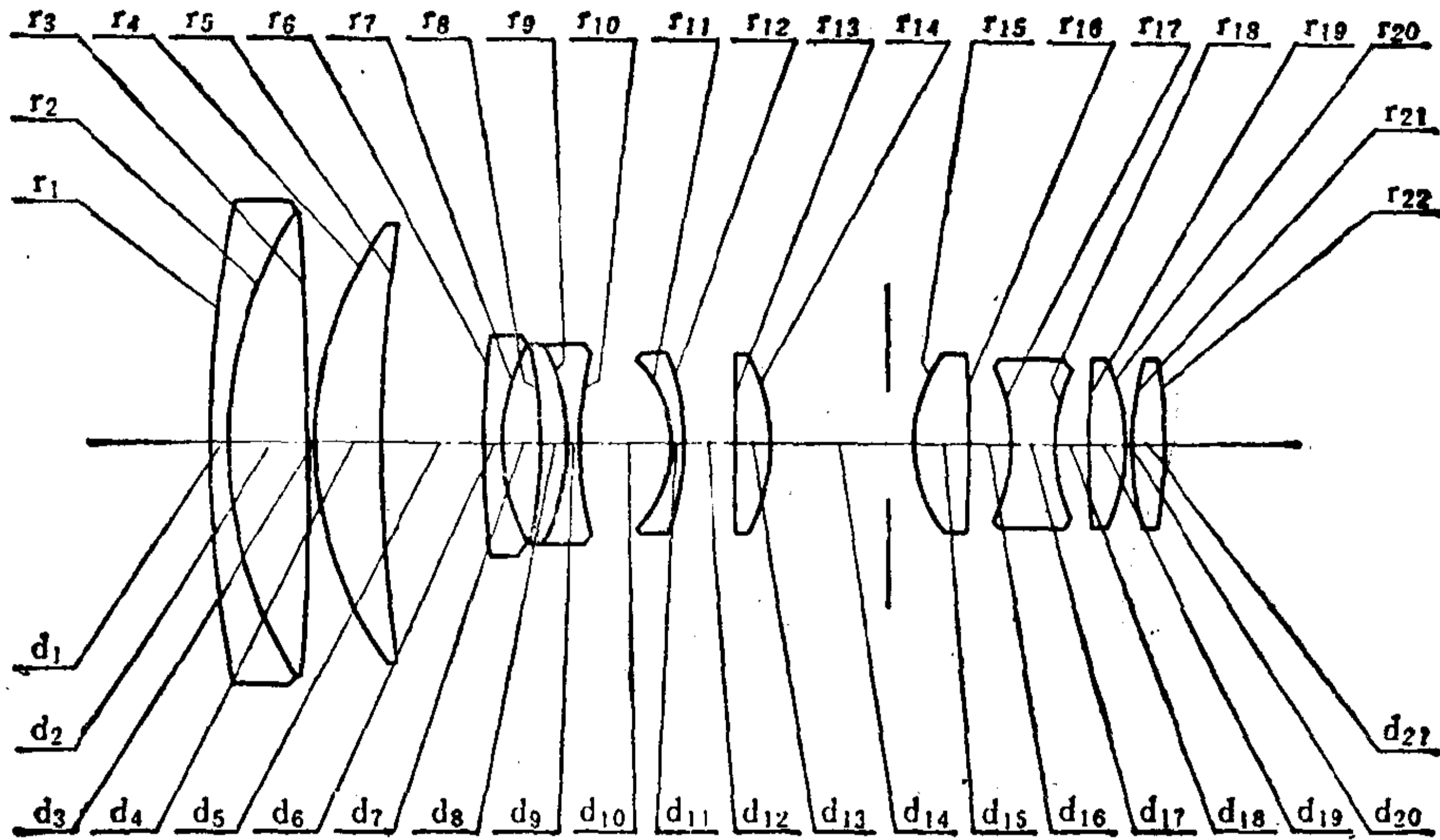

| 序号 | r        | d     | n       | v    | 序号 | r        | d     | n       | v    |
|----|----------|-------|---------|------|----|----------|-------|---------|------|
| 1  | 76.025   | 1.14  | 1.78472 | 25.7 | 12 | -16.451  | *** 3 |         |      |
| 2  | 27.438   | 5.02  | 1.71300 | 53.9 | 13 | ∞        | 2.10  | 1.71300 | 53.9 |
| 3  | -379.080 | 0.10  |         |      | 14 | -11.905  | 9.00* |         |      |
| 4  | 22.850   | 4.25  | 1.64000 | 60.2 | 15 | 9.269    | 3.43  | 1.74330 | 49.2 |
| 5  | 115.012  | *** 1 |         |      | 16 | -276.780 | 2.52  |         |      |
| 6  | 115.000  | 0.86  | 1.62041 | 60.3 | 17 | -11.104  | 2.87  | 1.78472 | 25.7 |
| 7  | 12.941   | 2.32  |         |      | 18 | 11.104   | 2.04  |         |      |
| 8  | -29.426  | 1.81  | 1.78472 | 25.7 | 19 | 255.200  | 2.23  | 1.62041 | 60.3 |
| 9  | -13.148  | 0.84  | 1.64000 | 60.2 | 20 | -12.686  | 0.10  |         |      |
| 10 | 22.105   | *** 2 |         |      | 21 | 19.386   | 2.00  | 1.62041 | 60.3 |
| 11 | -7.446   | 0.83  | 1.67270 | 32.2 | 22 | -32.200  |       |         |      |

9.00\* = 6.00 + 3.00

04-03-023-1

|                | $\Sigma S_1$ | $\Sigma S_2$ | $\Sigma S_3$ | $\Sigma S_4$ | $\Sigma S_5$  | HI        | QP(1 $\omega$ ) |
|----------------|--------------|--------------|--------------|--------------|---------------|-----------|-----------------|
|                | -0.01582     | 0.00272      | -0.01221     | -0.00062     | -0.04259      | 3.7       | -3.8%           |
| h 或 $\omega$ % | LA'          | $\Delta H'$  | $x'_i$       | $x'_s$       | $x'_i - x'_s$ | $K'_{T1}$ | $K'_{T0.7}$     |
| 100            | -0.219       | -0.143       | -0.594       | -0.165       | -0.429        | 0.0900    | 0.0268          |
| 70             | -0.117       | -0.049       | -0.300       | -0.095       | -0.205        | 0.0569    | 0.0168          |

E. F. L = 9.0 ( $\pm 22.3^\circ$ )

\*\*\* 1 = 0.088; \*\*\* 2 = 12.061; \*\*\* 3 = 3.210

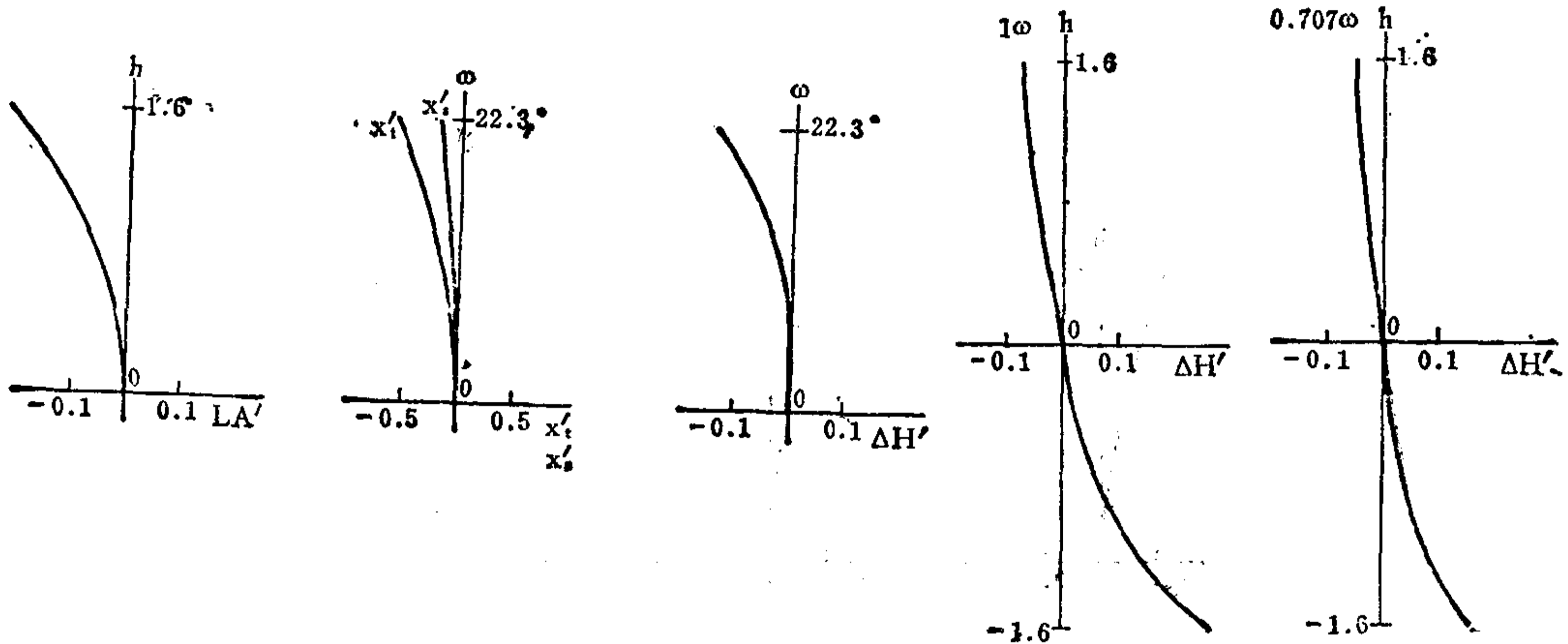

04-03-023-2

|                | $\Sigma S_1$ | $\Sigma S_2$ | $\Sigma S_3$ | $\Sigma S_4$ | $\Sigma S_5$  | HI        | QP(1 $\omega$ ) |
|----------------|--------------|--------------|--------------|--------------|---------------|-----------|-----------------|
|                | -0.01513     | 0.00820      | -0.01417     | -0.00065     | 0.01041       | 3.6       | 0.56%           |
| h 或 $\omega$ % | LA'          | $\Delta H'$  | $x'_i$       | $x'_s$       | $x'_i - x'_s$ | $K'_{T1}$ | $K'_{T0.7}$     |
| 100            | -0.203       | 0.0200       | -0.514       | -0.137       | -0.377        | 0.1206    | 0.0384          |
| 70             | -0.110       | 0.0037       | -0.263       | -0.082       | -0.181        | 0.0774    | 0.0253          |

E. F. L = 16.2 ( $\pm 12.4^\circ$ )

\*\*\* 1 = 6.541; \*\*\* 2 = 5.556; \*\*\* 3 = 3.262

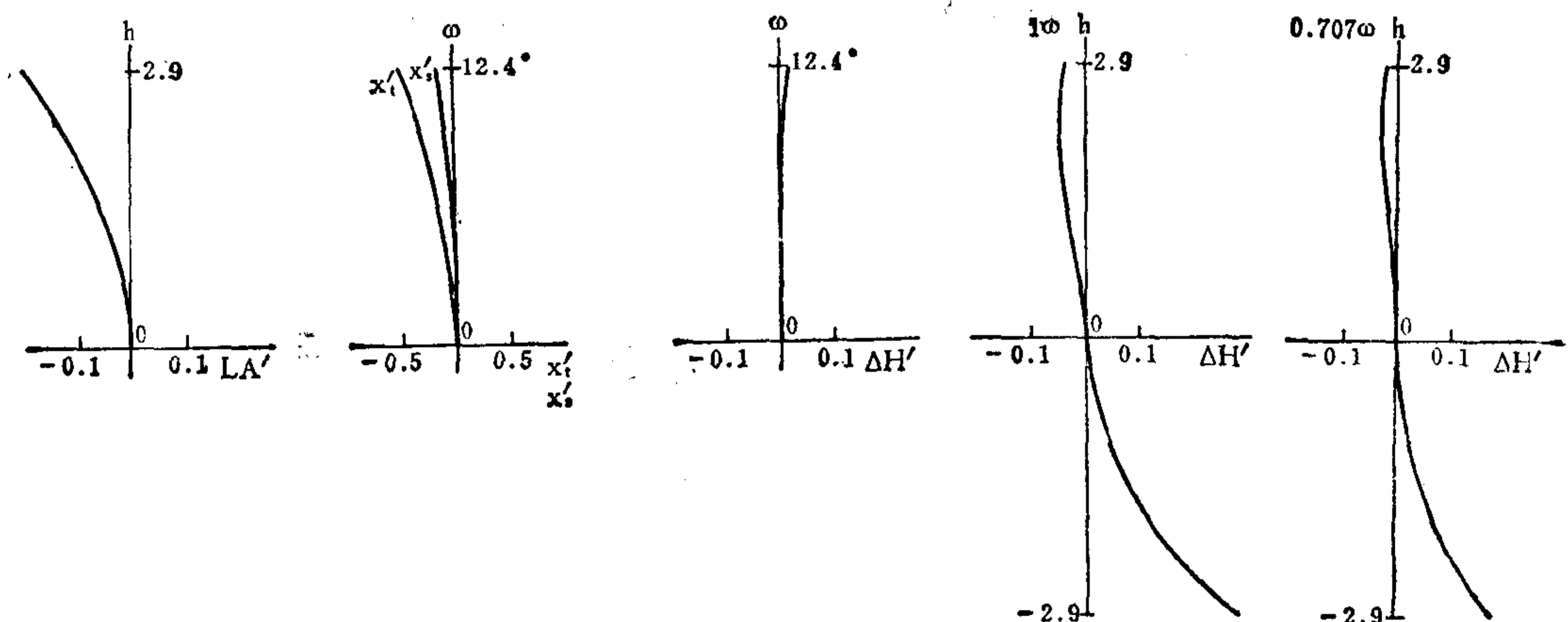

04-03-023-3

|                | $\Sigma S_1$ | $\Sigma S_2$ | $\Sigma S_3$ | $\Sigma S_4$ | $\Sigma S_5$  | HI        | QP(1 $\omega$ ) |
|----------------|--------------|--------------|--------------|--------------|---------------|-----------|-----------------|
|                | -0.00932     | 0.00105      | -0.00851     | -0.00065     | 0.03292       | 3.5       | 3.06%           |
| h 或 $\omega$ % | LA'          | $\Delta H'$  | $x'_t$       | $x'_s$       | $x'_t - x'_s$ | $K'_{T1}$ | $K'_{T0.7}$     |
| 100            | -0.111       | 0.108        | -0.412       | -0.107       | -0.305        | 0.02778   | -0.00036        |
| 70             | -0.065       | 0.033        | -0.201       | -0.063       | -0.138        | 0.02716   | 0.00367         |

E. F. L = 30.0 ( $\pm 6.7^\circ$ )

\*\*\* 1 = 11.421, \*\*\* 2 = 2.782, \*\*\* 3 = 1.156

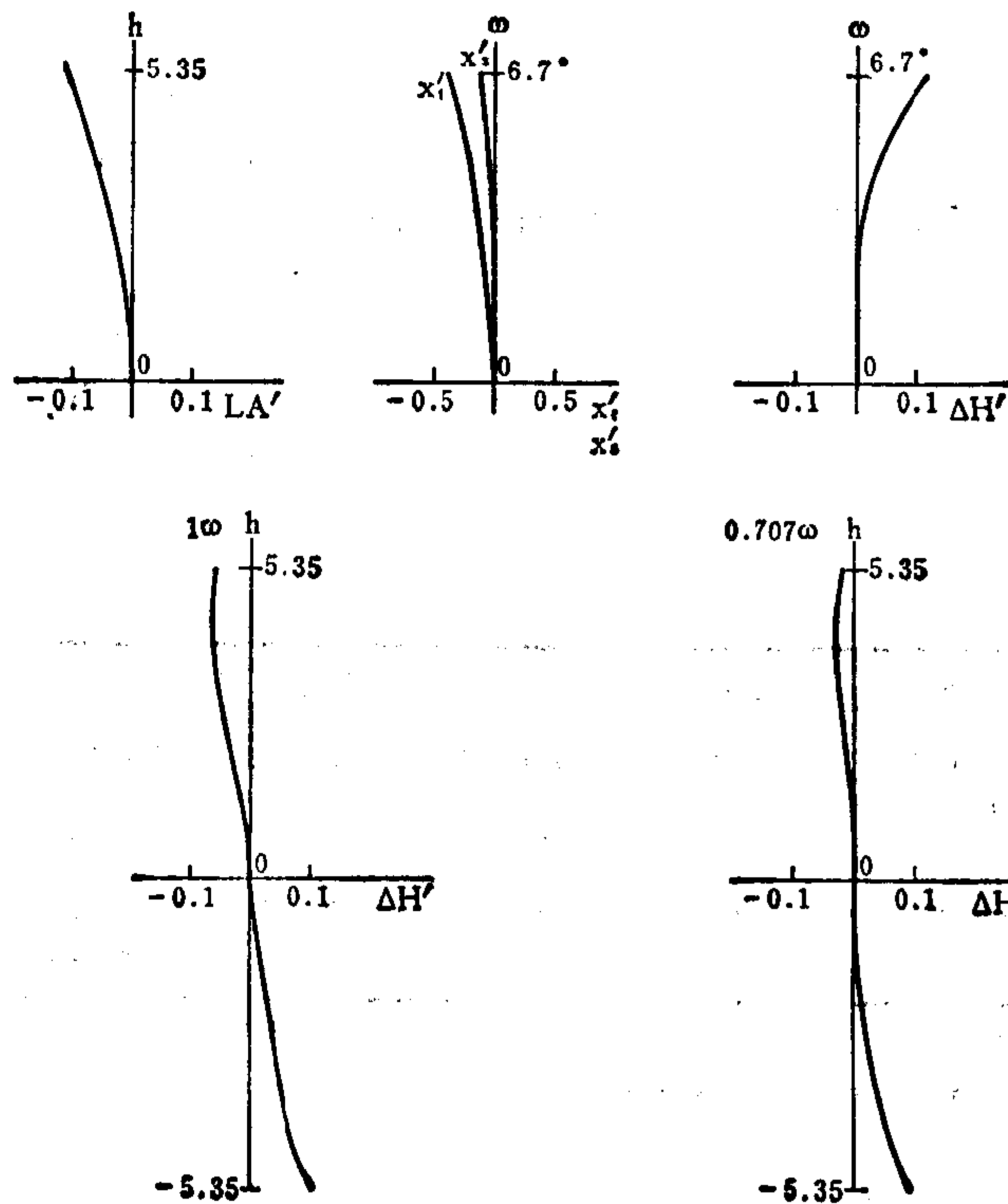

编号: 04-03-024

# 变 焦 距 镜 头

E.F.L=9.0~30.4 B.F.L=9.071 FNo.=3.6 F.A.=±22.3°~±6.7°

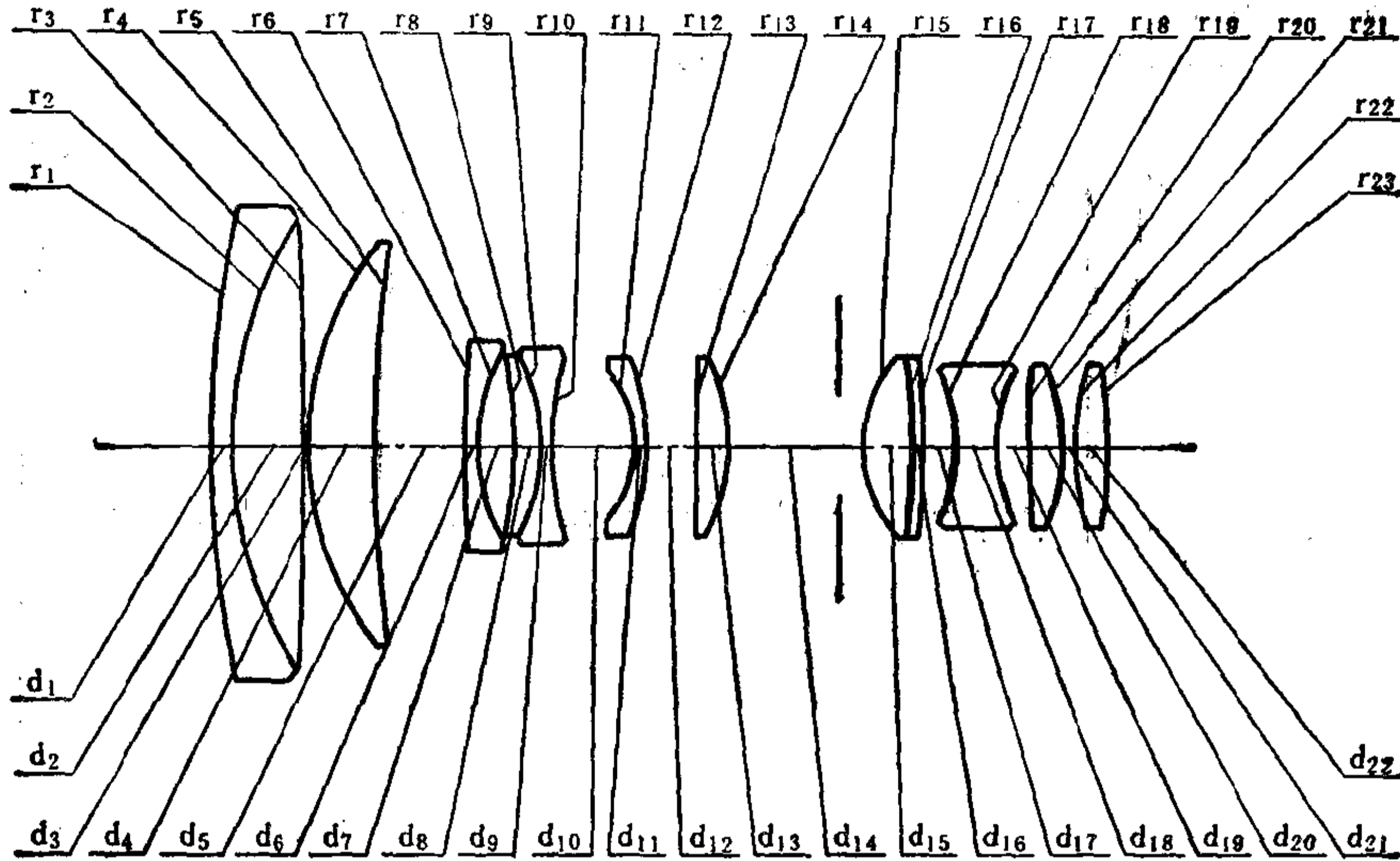

| 序号 | r        | d     | n       | v    | 序号 | r        | d     | n       | v    |
|----|----------|-------|---------|------|----|----------|-------|---------|------|
| 1  | 76.025   | 1.14  | 1.78472 | 25.7 | 13 | ∞        | 2.10  | 1.71300 | 53.0 |
| 2  | 27.438   | 5.02  | 1.71300 | 53.7 | 14 | -12.905  | 9.00* | 1.74330 | 49.2 |
| 3  | -379.080 | 0.10  |         |      | 15 | 9.269    | 3.43  | 1.74400 | 44.9 |
| 4  | 22.850   | 4.25  | 1.64000 | 60.2 | 16 | -40.000  | 0.80  | 1.78472 | 25.7 |
| 5  | 115.012  | *** 1 |         |      | 17 | -276.780 | 2.14  | 1.62041 | 60.3 |
| 6  | 115.000  | 0.86  | 1.62041 | 60.3 | 18 | -11.104  | 2.87  | 1.62041 | 60.3 |
| 7  | 12.941   | 2.32  |         |      | 19 | 11.104   | 2.04  |         |      |
| 8  | -29.426  | 1.81  | 1.78472 | 25.7 | 20 | 255.200  | 2.23  | 1.62041 | 60.3 |
| 9  | -13.148  | 0.84  | 1.64000 | 60.2 | 21 | -12.686  | 0.60  |         |      |
| 10 | 22.105   | *** 2 |         |      | 22 | 19.386   | 2.20  | 1.62041 | 60.3 |
| 11 | -7.446   | 0.83  | 1.67270 | 32.2 | 23 | -31.724  |       |         |      |
| 12 | -16.451  | *** 3 |         |      |    |          |       |         |      |

9.00\* = 6.00 + 3.00

04-03-024-1

|                | $\Sigma S_1$ | $\Sigma S_2$ | $\Sigma S_3$ | $\Sigma S_4$ | $\Sigma S_5$  | HI        | QP(1 $\omega$ ) |
|----------------|--------------|--------------|--------------|--------------|---------------|-----------|-----------------|
|                | -0.00360     | -0.00344     | -0.00209     | 0.00019      | -0.03845      | 3.7       | -4.4%           |
| h 或 $\omega$ % | LA'          | $\Delta H'$  | $x'_t$       | $x'_s$       | $x'_t - x'_s$ | $K'_{T1}$ | $K'_{T0.7}$     |
| 100            | -0.067       | -0.164       | -0.0856      | -0.0042      | -0.0814       | -0.0266   | -0.0176         |
| 70             | -0.041       | -0.056       | -0.0725      | -0.0179      | -0.0546       | -0.0185   | -0.0122         |

E. F. L = 9.1 ( $\pm 22.3^\circ$ )

\*\*\* 1 = 0.088; \*\*\* 2 = 12.061; \*\*\* 3 = 3.210

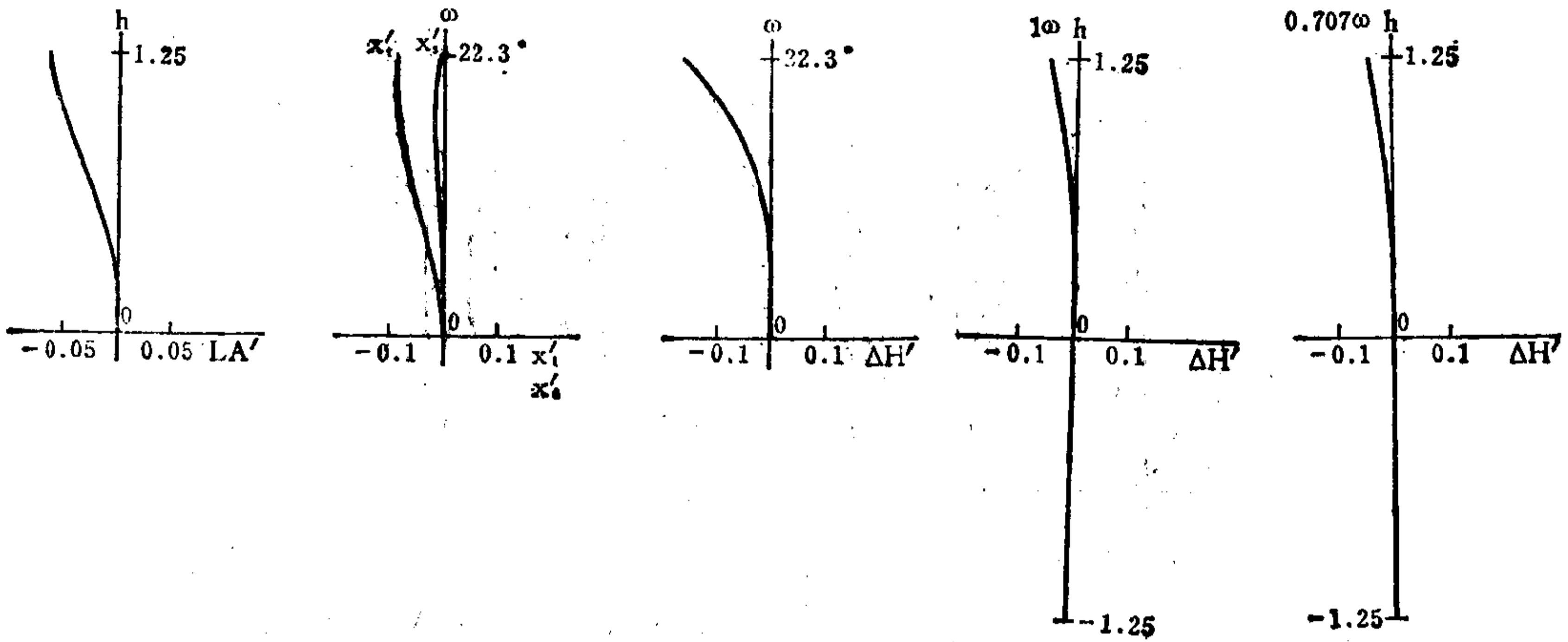

04-03-024-2

|                | $\Sigma S_1$ | $\Sigma S_2$ | $\Sigma S_3$ | $\Sigma S_4$ | $\Sigma S_5$  | HI        | QP(1 $\omega$ ) |
|----------------|--------------|--------------|--------------|--------------|---------------|-----------|-----------------|
|                | -0.00319     | -0.00152     | -0.00052     | 0.00019      | -0.00232      | 3.6       | 0.02%           |
| h 或 $\omega$ % | LA'          | $\Delta H'$  | $x'_t$       | $x'_s$       | $x'_t - x'_s$ | $K'_{T1}$ | $K'_{T0.7}$     |
| 100            | -0.056       | 0.0006       | 0.0040       | 0.0271       | -0.0231       | -0.01671  | -0.01322        |
| 70             | -0.035       | -0.0025      | -0.0338      | -0.0046      | -0.0292       | -0.00983  | -0.00815        |

E. F. L = 16.4 ( $\pm 12.4^\circ$ )

\*\*\* 1 = 6.541; \*\*\* 2 = 5.556; \*\*\* 3 = 3.262

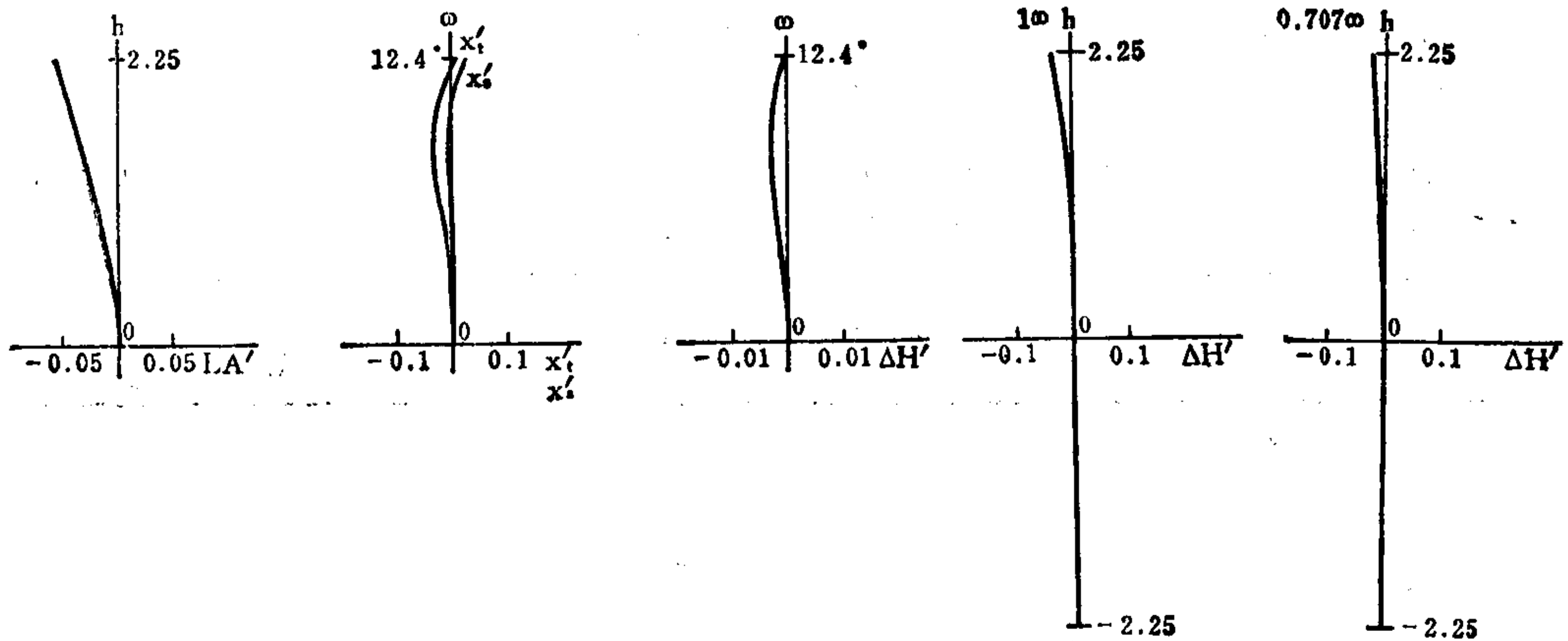

04-03-024-3

|                | $\Sigma S_1$ | $\Sigma S_2$ | $\Sigma S_3$ | $\Sigma S_4$ | $\Sigma S_5$ | HI       | QP(1 $\omega$ ) |
|----------------|--------------|--------------|--------------|--------------|--------------|----------|-----------------|
|                | -0.00112     | -0.00448     | 0.00125      | 0.00019      | 0.01857      | 3.6      | 2.5%            |
| h 或 $\omega$ % | LA'          | $\Delta H'$  | $x'_t$       | $x_s$        | $x'_t - x_s$ | $K_{T1}$ | $K_{T0.7}$      |
| 100            | -0.0017      | 0.0888       | 0.1121       | 0.0593       | 0.0528       | -0.05978 | -0.03282        |
| 70             | -0.0084      | 0.0275       | 0.0285       | 0.0147       | 0.0138       | -0.03500 | -0.01975        |

E. F. L = 30.4 ( $\pm 6.7^\circ$ )

\*\*\* 1 = 11.421; \*\*\* 2 = 2.782; \*\*\* 3 = 1.156

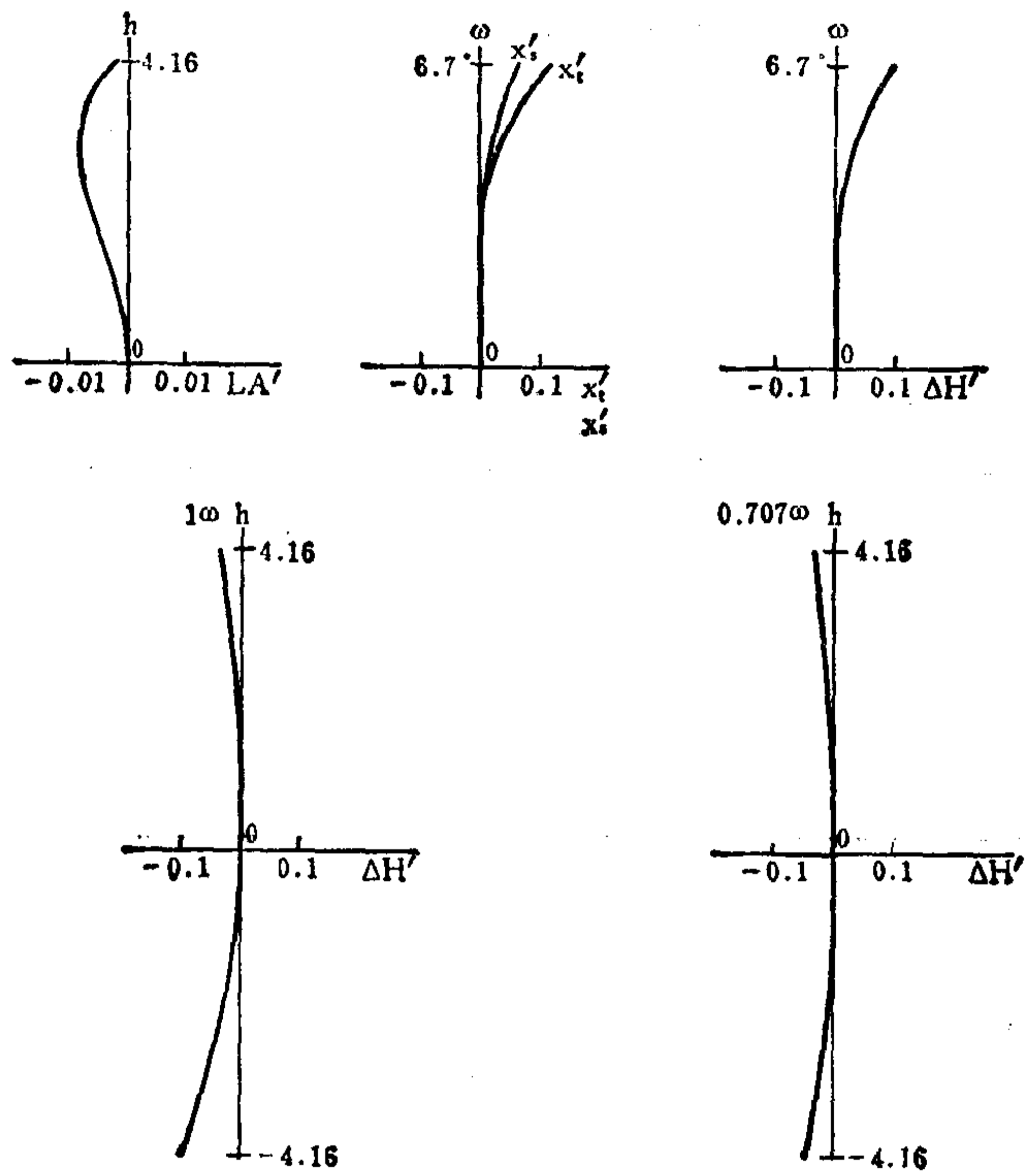

编号: 04-03-025

## 变焦距摄影物镜

E.F.L.=1.000~4.060 B.F.L.=0.830 FNo.=1.8 F.A.= $\pm 17.2^\circ \sim \pm 4.3^\circ$

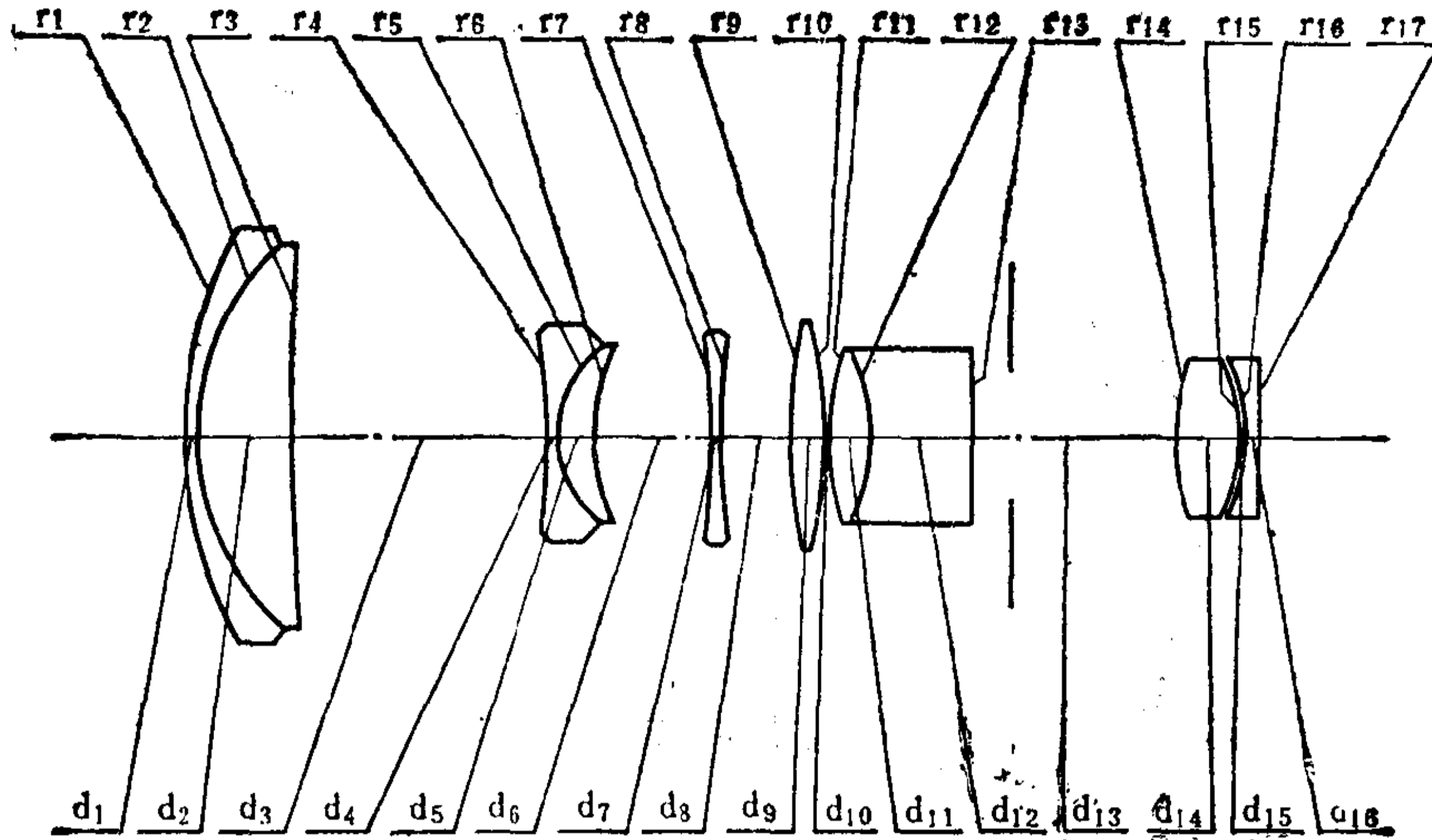

| 序号 | r       | d     | na     | va   | 序号 | r        | d      | na     | va   |
|----|---------|-------|--------|------|----|----------|--------|--------|------|
| 1  | 2.4770  | 0.080 | 1.7618 | 26.5 | 10 | -2.8300  | 0.010  |        |      |
| 2  | 1.5150  | 0.545 | 1.6237 | 47.0 | 11 | 1.7250   | 0.250  | 1.5725 | 57.5 |
| 3  | 26.3760 | *** 1 |        |      | 12 | -1.1404  | 0.600  | 1.7174 | 29.5 |
| 4  | -4.0140 | 0.050 | 1.6968 | 55.6 | 13 | $\infty$ | 1.200* |        |      |
| 5  | 0.6440  | 0.218 | 1.8061 | 40.7 | 14 | 1.3680   | 0.370  | 1.6074 | 56.7 |
| 6  | 1.2215  | *** 2 |        |      | 15 | -1.0590  | 0.010  |        |      |
| 7  | -6.4220 | 0.080 | 1.6385 | 55.5 | 16 | -0.9880  | 0.090  | 1.5927 | 35.4 |
| 8  | 6.4220  | *** 3 |        |      | 17 | -50.8400 |        |        |      |
| 9  | 3.2970  | 0.200 | 1.6433 | 47.8 |    |          |        |        |      |

1.200\* = 0.100 + 1.100



04-03-025-1

|                | $\Sigma S_1$ | $\Sigma S_2$ | $\Sigma S_3$ | $\Sigma S_4$ | $\Sigma S_5$  | HI       | QP(1 $\omega$ ) |
|----------------|--------------|--------------|--------------|--------------|---------------|----------|-----------------|
|                | 0.00355      | -0.00273     | 0.00021      | -0.00187     | -0.01076      | 0.31     | -6.1%           |
| h 或 $\omega$ % | LA'          | $\Delta H'$  | $x'_t$       | $x'_s$       | $x'_t - x'_s$ | $K_{T1}$ | $K_{T0.7}$      |
| 100            | 0.0669       | -0.0192      | -0.0231      | -0.0099      | -0.0132       | -0.5443  | 0.0136          |
| 70             | 0.0201       | -0.0071      | -0.0017      | -0.0037      | 0.0020        | -0.0040  | -0.0045         |

E. F. L = 1.015 ( $\pm 17.2^\circ$ )

\*\*\* 1 = 0.01561; \*\*\* 2 = 2.49315; \*\*\* 3 = 0.08000

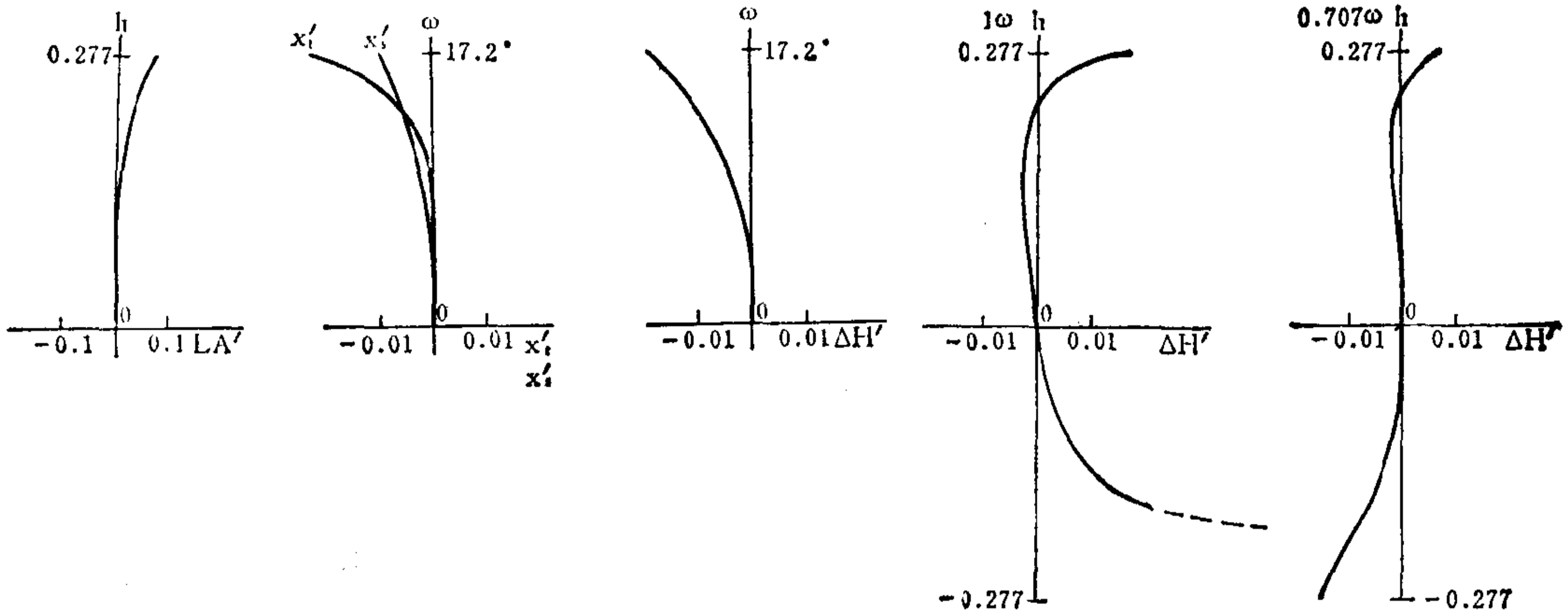

04-03-025-2

|                | $\Sigma S_1$ | $\Sigma S_2$ | $\Sigma S_3$ | $\Sigma S_4$ | $\Sigma S_5$  | HI       | QP(1 $\omega$ ) |
|----------------|--------------|--------------|--------------|--------------|---------------|----------|-----------------|
|                | 0.00545      | -0.00324     | 0.00080      | -0.00191     | -0.00375      | 0.31     | -2.4%           |
| h 或 $\omega$ % | LA'          | $\Delta H'$  | $x'_t$       | $x'_s$       | $x'_t - x'_s$ | $K_{T1}$ | $K_{T0.7}$      |
| 100            | 0.0701       | -0.0075      | 0.0129       | -0.0048      | 0.0177        | 0.0417   | -0.0084         |
| 70             | 0.0248       | -0.0025      | 0.0042       | -0.0030      | 0.0072        | -0.0095  | -0.0071         |

E. F. L = 2.278 ( $\pm 7.6^\circ$ )

\*\*\* 1 = 1.515610; \*\*\* 2 = 0.680222; \*\*\* 3 = 0.392930

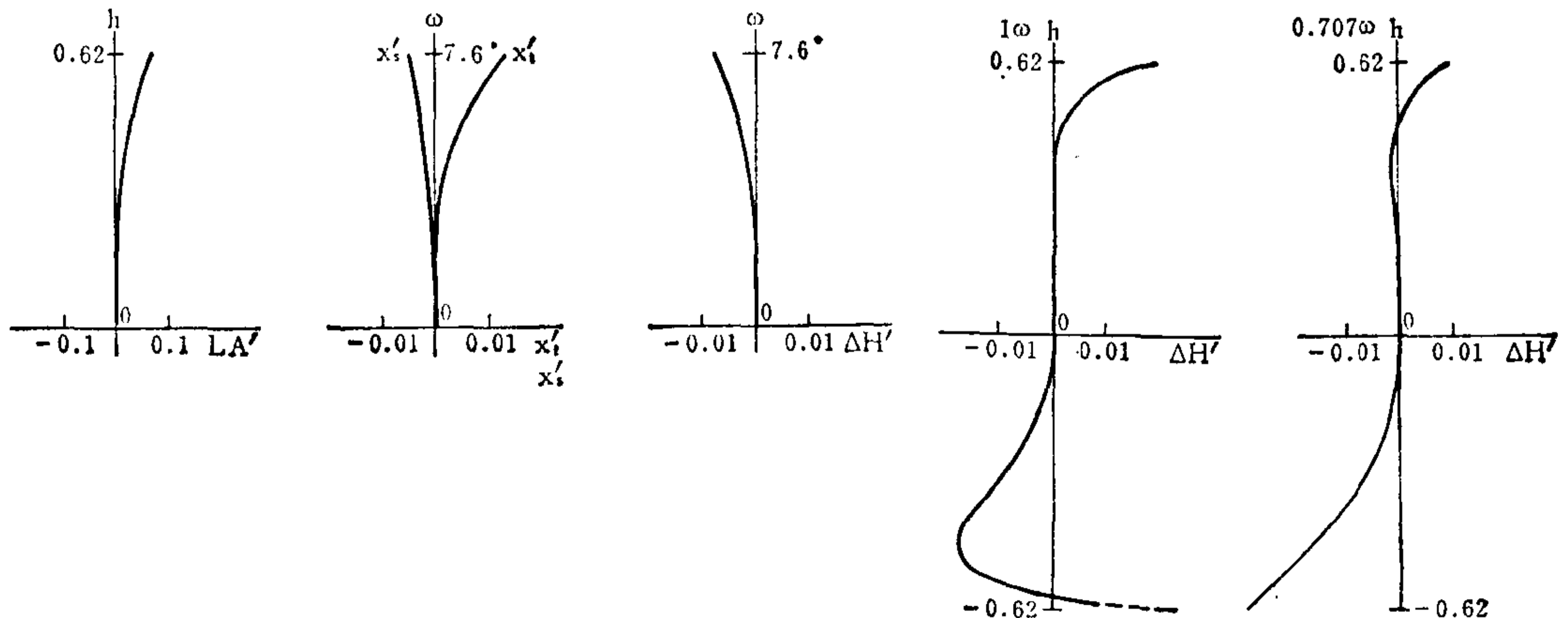



04-03-025-3

|                | $\Sigma S_1$ | $\Sigma S_2$ | $\Sigma S_3$ | $\Sigma S_4$ | $\Sigma S_5$  | HI        | QP(1 $\omega$ ) |
|----------------|--------------|--------------|--------------|--------------|---------------|-----------|-----------------|
|                | 0.00684      | 0.00033      | -0.00047     | -0.00193     | -0.00062      | 0.31      | -0.78%          |
| h 或 $\omega$ % | LA'          | $\Delta H'$  | $x'_t$       | $x'_s$       | $x'_t - x'_s$ | $K'_{T1}$ | $K_{T0.7}$      |
| 100            | 0.0368       | -0.0024      | 0.0122       | -0.0094      | 0.0216        | -0.8881   | -0.0328         |
| 70             | 0.0247       | -0.0006      | -0.0036      | -0.0066      | 0.0030        | -0.4958   | -0.0101         |

E. F. L = 4.060 ( $\pm 4.3^\circ$ )

\*\*\* 1 = 2.26561; \*\*\* 2 = 0.24315; \*\*\* 3 = 0.08000

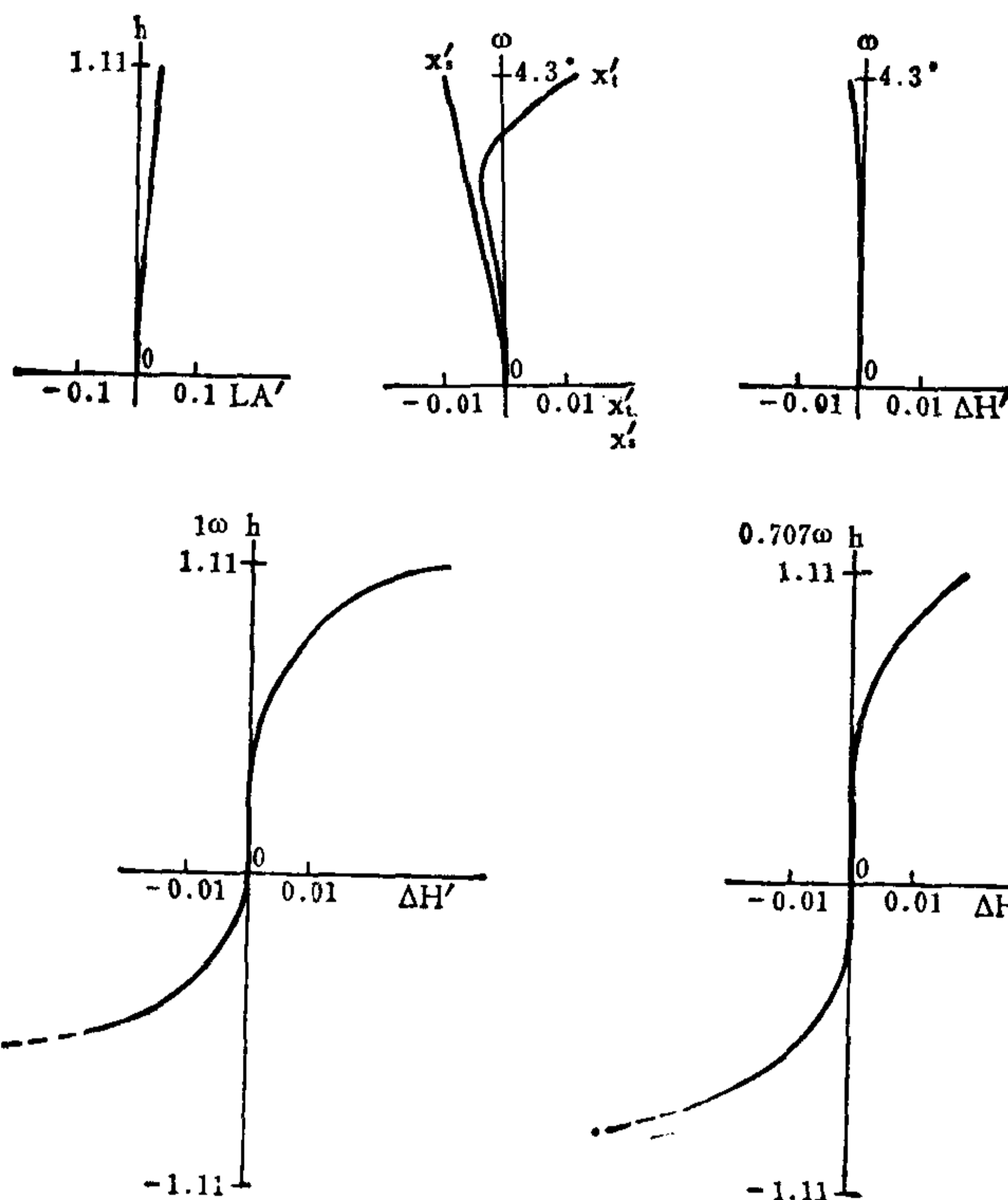

编号: 04-03-026

### 可动透镜作线性差动式移动的变焦距镜头

E.F.L=12.00~32.30 B.F.L=12.0 FNo. = 2 F.A. = ±14.3° ~ ±5.4°

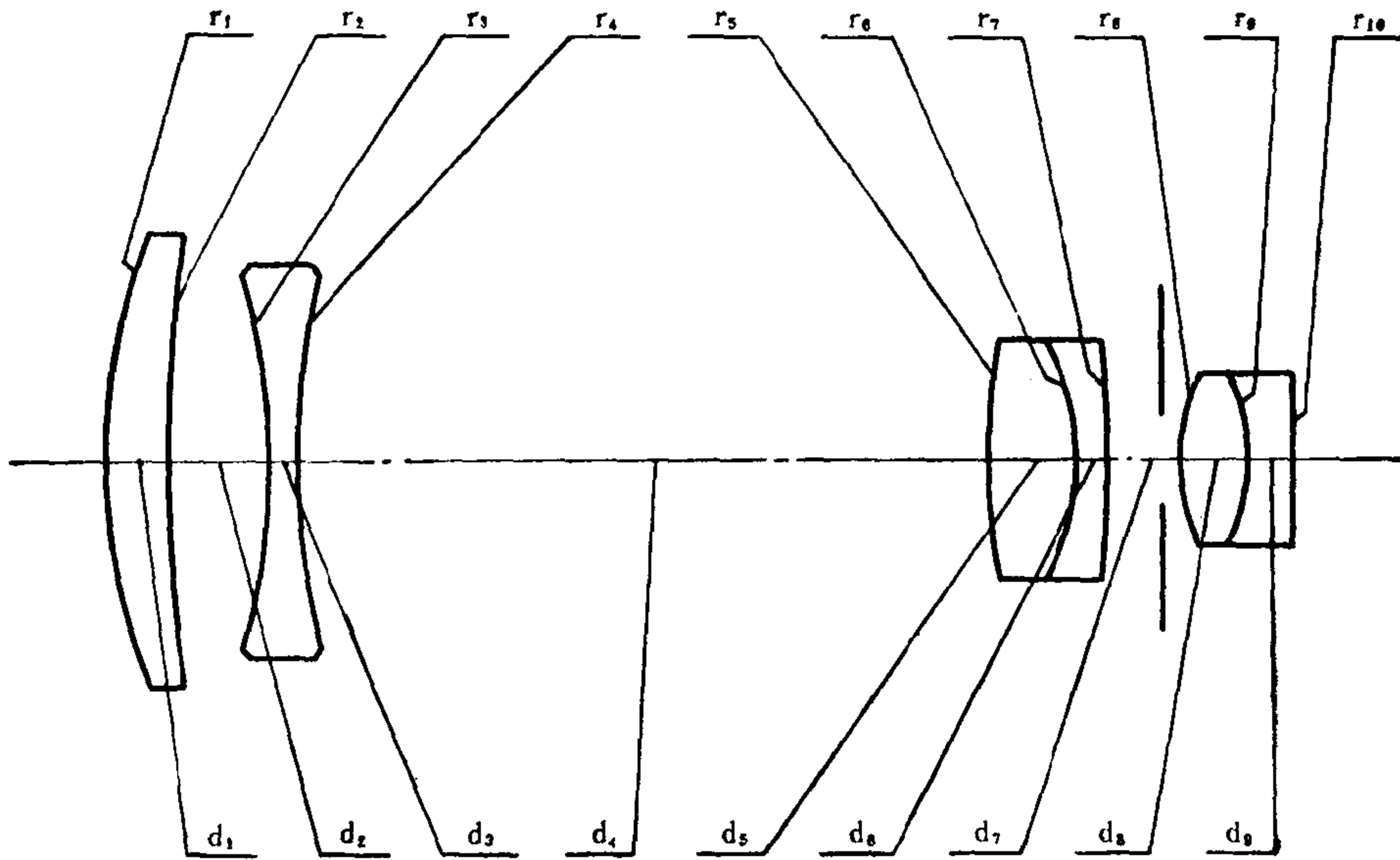

| 序号 | r       | d     | n <sub>D</sub> | v <sub>D</sub> | 序号 | r       | d      | n <sub>D</sub> | v <sub>D</sub> |
|----|---------|-------|----------------|----------------|----|---------|--------|----------------|----------------|
| 1  | 35.650  | 3.840 | 1.620          | 60.3           | 6  | -14.489 | 1.840  | 1.617          | 36.6           |
| 2  | 92.945  | *** 1 |                |                | 7  | -81.067 | *** 3* |                |                |
| 3  | -39.960 | 1.840 | 1.620          | 60.3           | 8  | 11.420  | 3.840  | 1.617          | 54.9           |
| 4  | 45.794  | *** 2 |                |                | 9  | -11.420 | 2.780  | 1.720          | 29.3           |
| 5  | 38.768  | 5.070 | 1.617          | 54.9           | 10 | ∞       |        |                |                |

04-03-026-1

|                | $\Sigma S_1$ | $\Sigma S_2$ | $\Sigma S_3$ | $\Sigma S_4$ | $\Sigma S_5$ | HI        | QP(1 $\omega$ ) |
|----------------|--------------|--------------|--------------|--------------|--------------|-----------|-----------------|
|                | -0.01021     | -0.00311     | -0.00492     | -0.01840     | -0.16168     | 3.1       | -9.4%           |
| h 或 $\omega$ % | LA'          | $\Delta H'$  | $x'_t$       | $x'_s$       | $x_t - x_s$  | $K'_{T1}$ | $K'_{T0.7}$     |
| 100            | -0.0106      | -0.2897      | -0.2295      | -0.1415      | -0.0880      | -0.0255   | -0.0023         |
| 70             | -0.0257      | -0.1060      | -0.1193      | -0.0802      | -0.0391      | -0.0071   | -0.0003         |

E. F. L = 12.00 ( $\pm 14.3^\circ$ )

\*\*\* 1 = 5.620; \*\*\* 2 = 40.530; \*\*\* 3 = 5.730; \*\*\* 3\* = 5.730 = 4.270 + 1.460

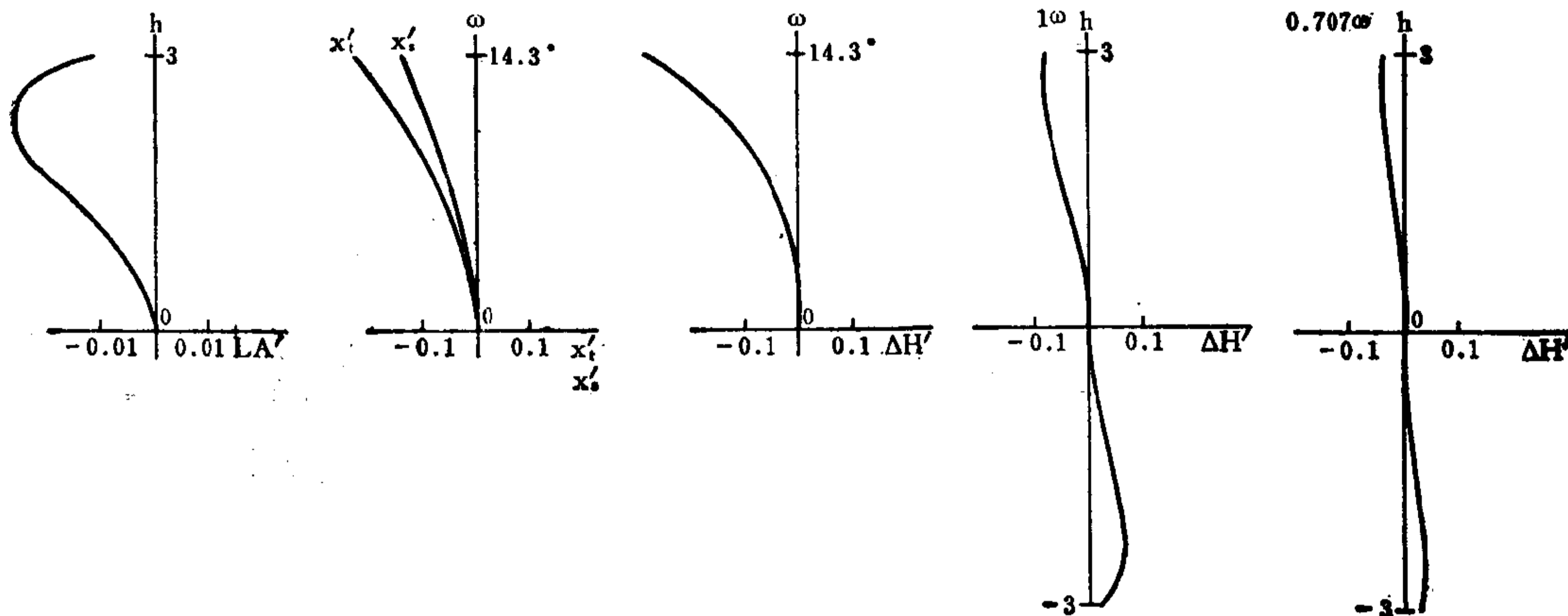

04-03-026-2

|                | $\Sigma S_1$ | $\Sigma S_2$ | $\Sigma S_3$ | $\Sigma S_4$ | $\Sigma S_5$ | HI        | QP(1 $\omega$ ) |
|----------------|--------------|--------------|--------------|--------------|--------------|-----------|-----------------|
|                | -0.01049     | 0.00048      | -0.00506     | -0.01883     | -0.03405     | 3.04      | -2.3%           |
| h 或 $\omega$ % | LA'          | $\Delta H'$  | $x'_t$       | $x'_s$       | $x_t - x_s$  | $K'_{T1}$ | $K'_{T0.7}$     |
| 100            | -0.0155      | -0.0708      | -0.1977      | -0.1665      | -0.0312      | -0.0668   | -0.0226         |
| 70             | -0.0278      | -0.0243      | -0.1180      | -0.0903      | -0.0277      | -0.0237   | -0.0072         |

E. F. L = 32.30 ( $\pm 5.4^\circ$ )

\*\*\* 1 = 24.890; \*\*\* 2 = 1.990; \*\*\* 3 = 25.000; \*\*\* 3\* = 25.000 = 23.540 + 1.460

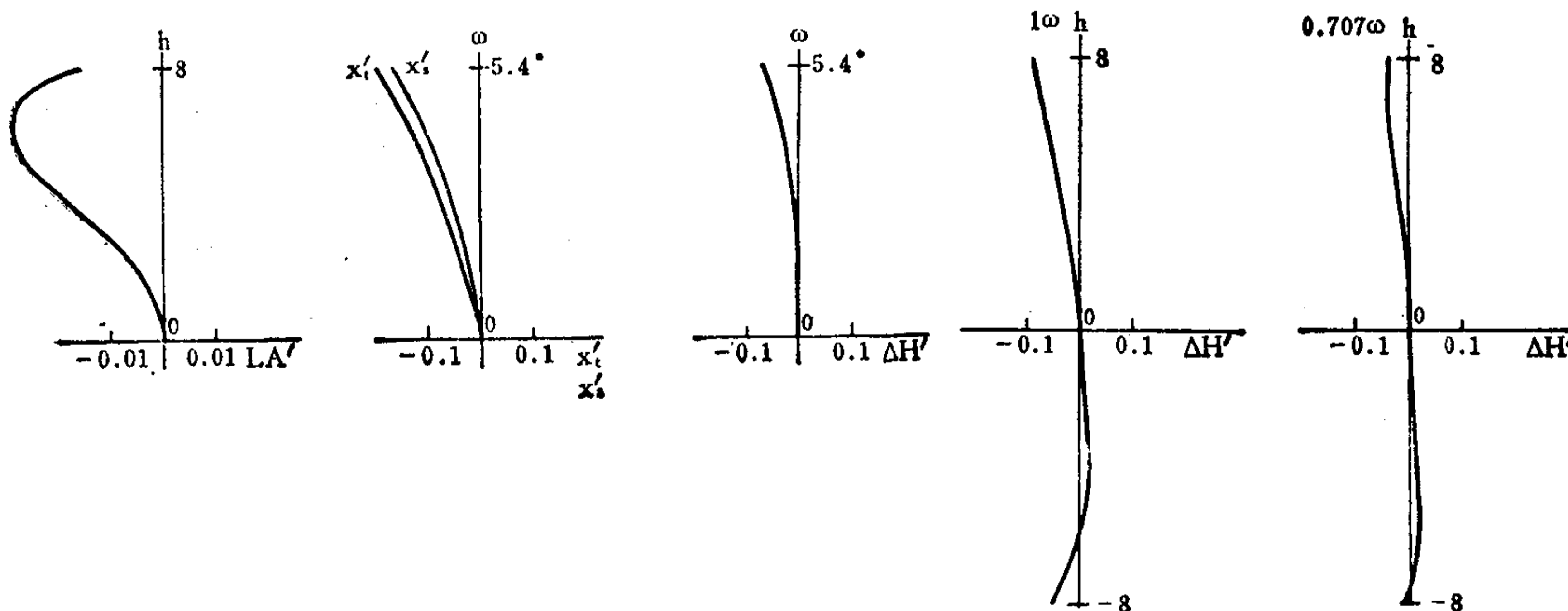

编号: 04-03-027

# 大孔径变焦距物镜

E.F.L = 10.30 ~ 30.00 B.F.L = 13.050 FNo. = 1.8 F.A. = ±19.5° ~ ±6.7°

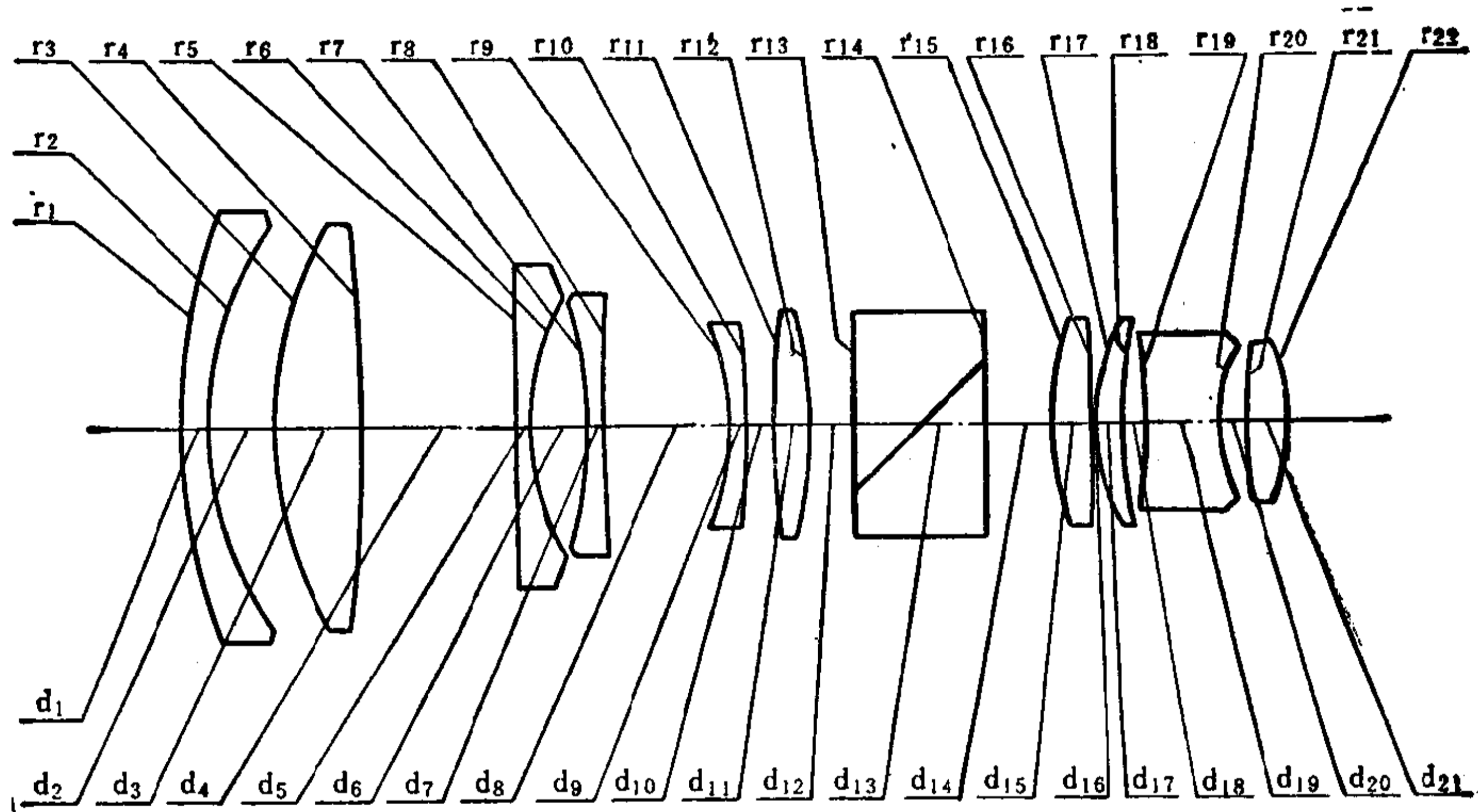

| 序号 | r       | d     | $n_e$  | $v_e$ | 序号 | r        | d     | $n_e$  | $v_e$ |
|----|---------|-------|--------|-------|----|----------|-------|--------|-------|
| 1  | 41.42   | 1.80  | 1.7917 | 25.8  | 12 | -32.91   | 3.10  |        |       |
| 2  | 24.03   | 4.50  |        |       | 13 | $\infty$ | 9.00  | 1.5187 | 63.9  |
| 3  | 27.05   | 6.00  | 1.6808 | 54.9  | 14 | $\infty$ | 4.50* |        |       |
| 4  | -183.60 | *** 1 |        |       | 15 | 22.56    | 2.55  | 1.6940 | 54.4  |
| 5  | 2727.00 | 1.00  | 1.4891 | 70.2  | 16 | -106.20  | 0.05  |        |       |
| 6  | 16.99   | 3.70  |        |       | 17 | 13.29    | 1.80  | 1.6940 | 54.4  |
| 7  | -29.74  | 1.00  | 1.4891 | 70.2  | 18 | 30.04    | 1.40  |        |       |
| 8  | 279.40  | *** 2 |        |       | 19 | -36.19   | 4.90  | 1.8126 | 25.2  |
| 9  | -18.46  | 1.00  | 1.4891 | 70.2  | 20 | 10.99    | 2.25  |        |       |
| 10 | -70.15  | *** 3 |        |       | 21 | 32.69    | 2.45  | 1.7161 | 53.6  |
| 11 | 60.03   | 2.40  | 1.6713 | 41.6  | 22 | -14.61   |       |        |       |

4.50\* = 3.00 + 1.50

04-03-027-1

|                | $\Sigma S_1$ | $\Sigma S_2$ | $\Sigma S_3$ | $\Sigma S_4$ | $\Sigma S_5$  | HI        | QP(1 $\omega$ ) |
|----------------|--------------|--------------|--------------|--------------|---------------|-----------|-----------------|
|                | -0.01942     | -0.01218     | -0.00128     | -0.01015     | -0.06611      | 3.6       | -3.6%           |
| h 或 $\omega$ % | LA'          | $\Delta H'$  | $x'_t$       | $x'_s$       | $x'_t - x'_s$ | $K'_{T1}$ | $K'_{T0.7}$     |
| 100            | -0.0271      | -0.1321      | -0.0645      | -0.0616      | -0.0029       | 0.1818    | 0.0282          |
| 70             | -0.0458      | -0.0453      | -0.0363      | -0.0334      | -0.0029       | 0.0985    | 0.0093          |

E. F. L = 10.30 ( $\pm 19.5^\circ$ )

\*\*\* 1 = 0.15; \*\*\* 2 = 27.05; \*\*\* 3 = 2.10

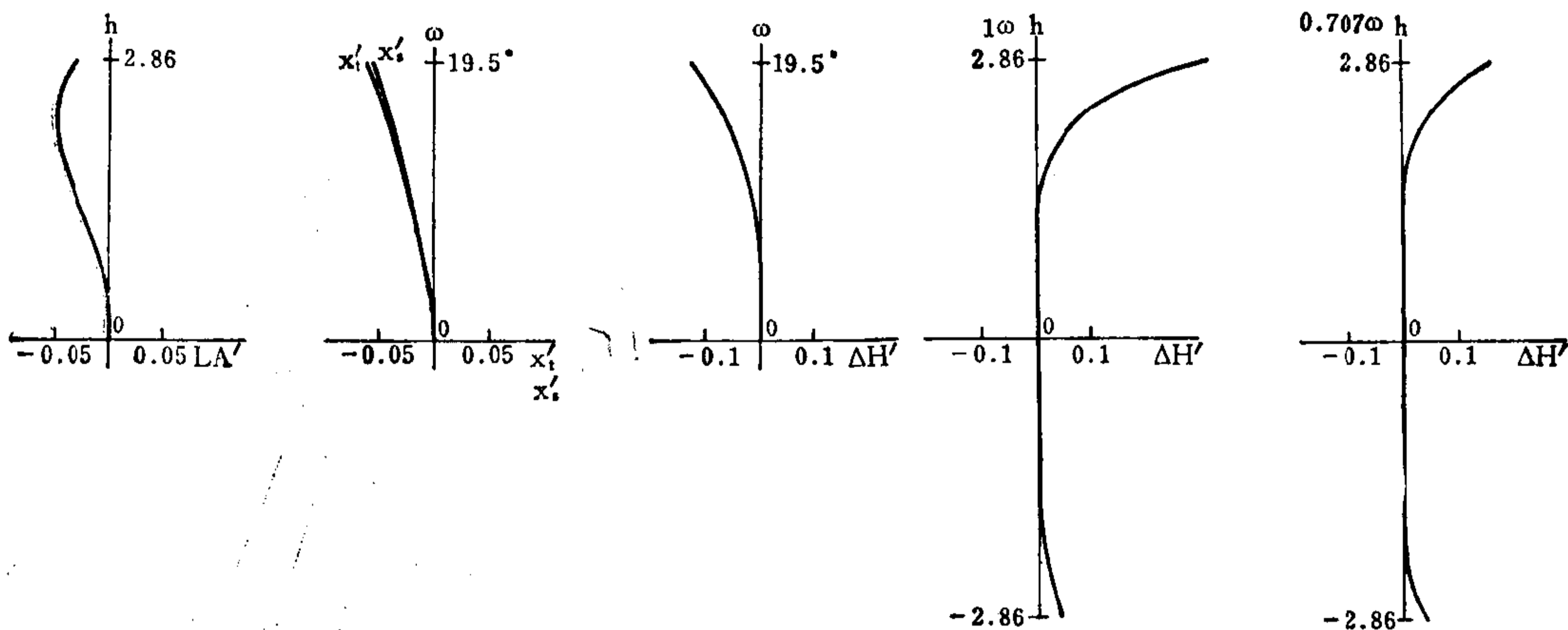

04-03-027-2

|                | $\Sigma S_1$ | $\Sigma S_2$ | $\Sigma S_3$ | $\Sigma S_4$ | $\Sigma S_5$  | HI        | QP(1 $\omega$ ) |
|----------------|--------------|--------------|--------------|--------------|---------------|-----------|-----------------|
|                | -0.01168     | -0.00577     | -0.00144     | -0.01046     | 0.00948       | 3.5       | 0.27%           |
| h 或 $\omega$ % | LA'          | $\Delta H'$  | $x'_t$       | $x'_s$       | $x'_t - x'_s$ | $K'_{T1}$ | $K'_{T0.7}$     |
| 100            | 0.0256       | 0.0098       | 0.0257       | -0.0490      | 0.0747        | 0.2203    | 0.0336          |
| 70             | -0.0203      | 0.0047       | -0.0288      | -0.0343      | 0.0055        | 0.1184    | 0.0159          |

E. F. L = 20.00 ( $\pm 10^\circ$ )

\*\*\* 1 = 16.31; \*\*\* 2 = 8.75; \*\*\* 3 = 4.24

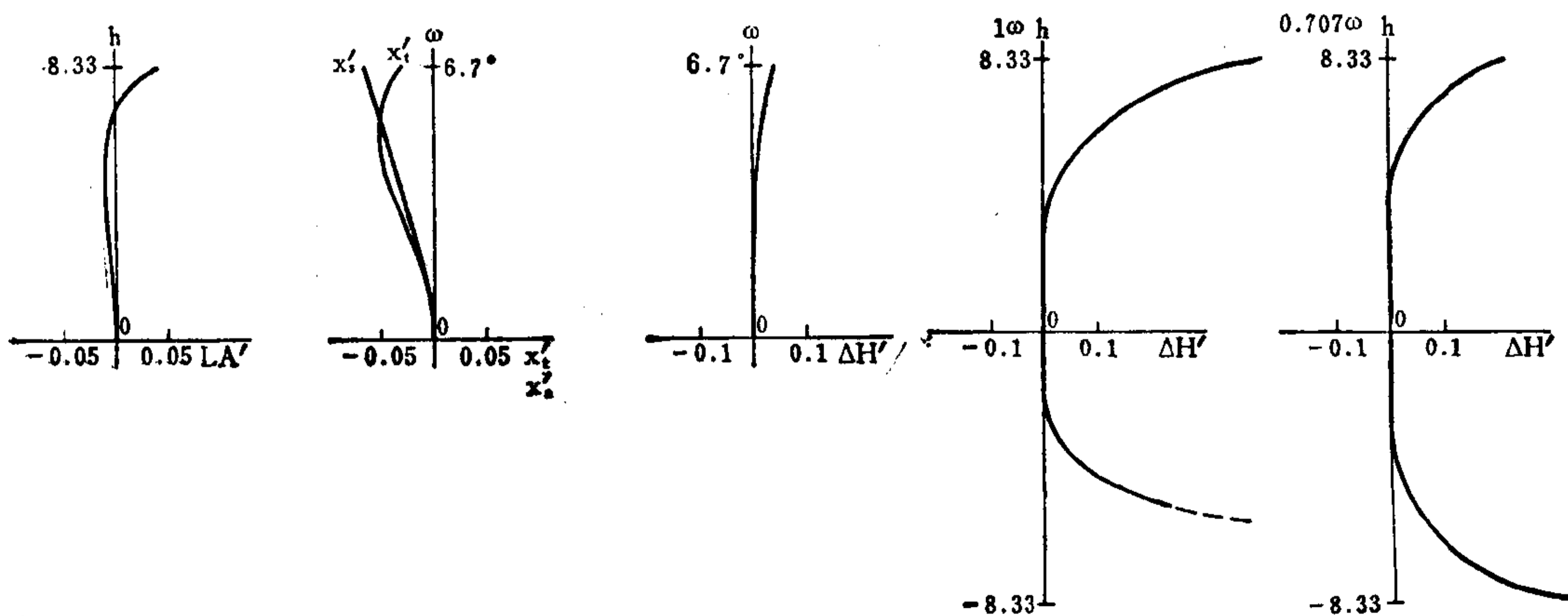

04-03-027-3

|                | $\Sigma S_1$ | $\Sigma S_2$ | $\Sigma S_3$ | $\Sigma S_4$ | $\Sigma S_5$  | HI        | QP(1 $\omega$ ) |
|----------------|--------------|--------------|--------------|--------------|---------------|-----------|-----------------|
|                | -0.00649     | -0.00134     | -0.00553     | -0.01048     | 0.02824       | 3.5       | 1.2%            |
| h 或 $\omega$ % | LA'          | $\Delta H'$  | $x'_t$       | $x_s$        | $x'_t - x'_s$ | $K'_{I1}$ | $K'_{T0.7}$     |
| 100            | 0.0402       | 0.0420       | -0.0239      | -0.0665      | 0.0376        | -10.9150  | 0.2425          |
| 70             | -0.0070      | 0.0163       | -0.0503      | -0.0431      | -0.0072       | 0.2785    | 0.0411          |

E. F. L = 30.00 ( $\pm 6.7^\circ$ )

\*\*\* 1 = 23.91; \*\*\* 2 = 2.41; \*\*\* 3 = 2.98

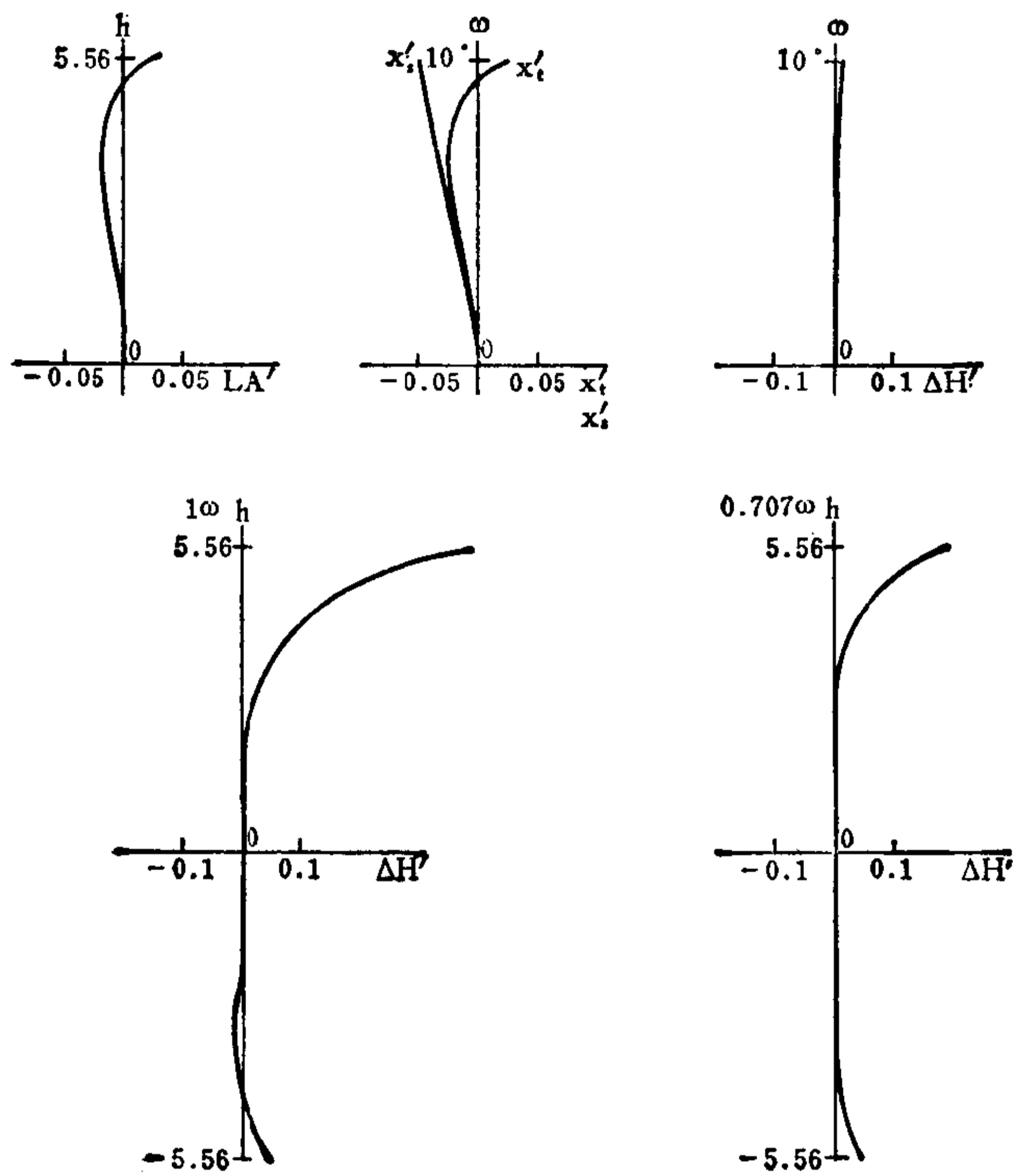

编号: 04-03-028

## 变 焦 距 物 镜

E.F.L.=72~203 B.F.L.=40.00 FNo.=4 F.A.=±19.1°~±6.8°

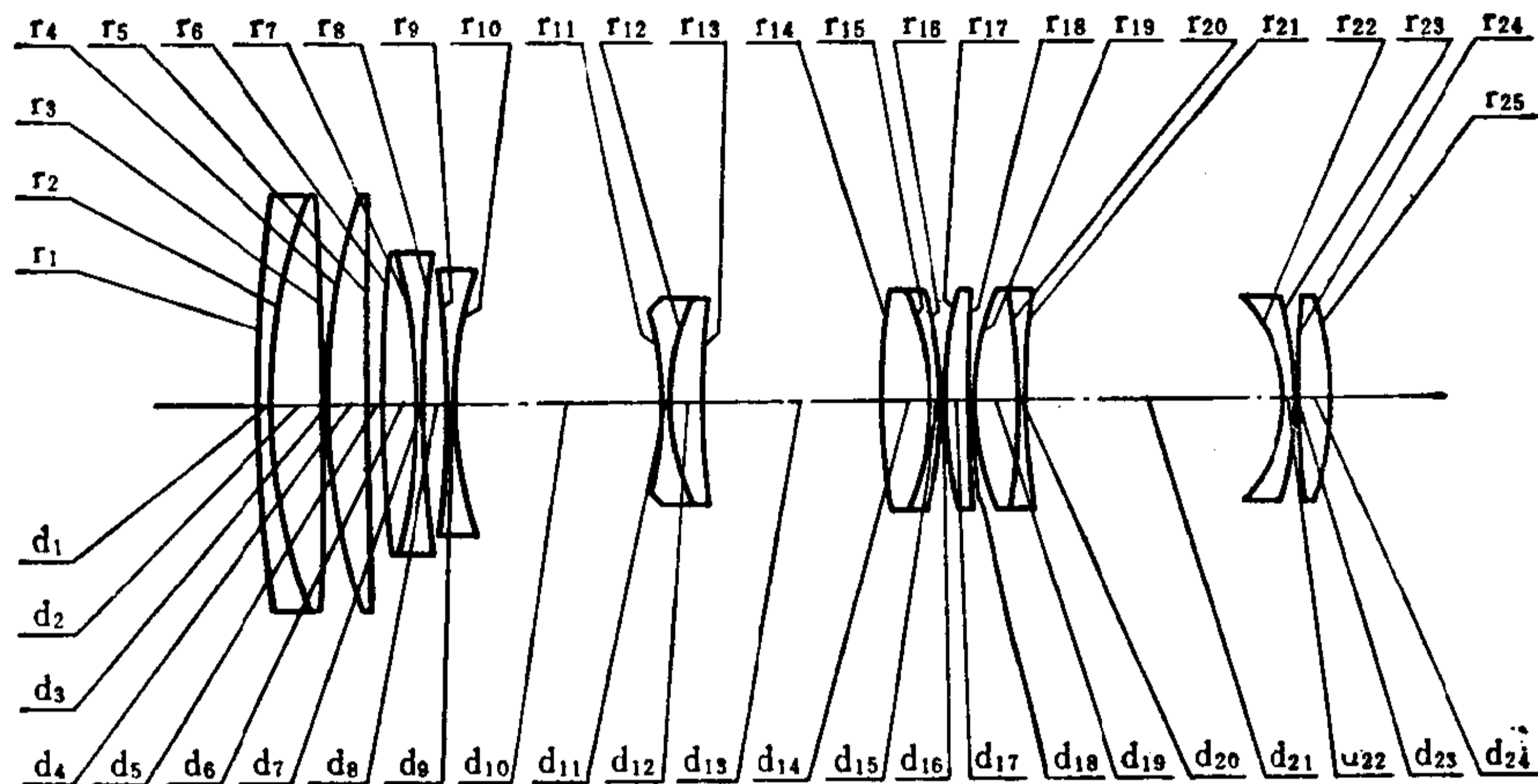

| 序号 | r       | d     | nd      | v    | 序号 | r       | d       | nd      | v    |
|----|---------|-------|---------|------|----|---------|---------|---------|------|
| 1  | 268.54  | 1.900 | 1.71736 | 29.5 | 14 | 88.43   | 6.500   | 1.48749 | 70.0 |
| 2  | 80.13   | 6.900 | 1.58913 | 61.2 | 15 | -36.55  | 1.460   | 1.80518 | 25.5 |
| 3  | -410.77 | 0.300 |         |      | 16 | -56.17  | 0.300   |         |      |
| 4  | 90.60   | 5.300 | 1.51009 | 63.4 | 17 | 61.15   | 3.870   | 1.48749 | 70.0 |
| 5  | 3376.49 | *** 1 |         |      | 18 | 284.27  | 0.300   |         |      |
| 6  | 222.96  | 4.700 | 1.78472 | 25.7 | 19 | 38.35   | 6.000   | 1.48749 | 70.0 |
| 7  | -81.30  | 1.300 | 1.66672 | 48.4 | 20 | -104.13 | 1.023   | 1.64328 | 47.8 |
| 8  | 154.03  | 2.700 |         |      | 21 | 94.78   | 49.846* |         |      |
| 9  | -184.02 | 1.000 | 1.66672 | 48.4 | 22 | -20.19  | 1.480   | 1.69700 | 48.5 |
| 10 | 51.53   | *** 2 |         |      | 23 | -53.33  | 0.267   |         |      |
| 11 | -47.69  | 1.000 | 1.52249 | 59.6 | 24 | 135.84  | 4.000   | 1.58921 | 41.0 |
| 12 | 33.79   | 4.800 | 1.62588 | 35.6 | 25 | -53.64  |         |         |      |
| 13 | 153.92  | *** 3 |         |      |    |         |         |         |      |

49.846\* = 1.000 + 48.846

04-03-028-1

|                | $\Sigma S_1$ | $\Sigma S_2$ | $\Sigma S_3$ | $\Sigma S_4$ | $\Sigma S_5$  | HI        | QP(1 $\omega$ ) |
|----------------|--------------|--------------|--------------|--------------|---------------|-----------|-----------------|
|                | -0.0236      | -0.0087      | -0.0016      | -0.0033      | -0.1813       | 24.9      | -3.6%           |
| h 或 $\omega$ % | LA'          | $\Delta H'$  | $x'_t$       | $x'_s$       | $x'_t - x'_s$ | $K'_{T1}$ | $K'_{T0.7}$     |
| 100            | 0.0235       | -0.905       | -0.0148      | 0.1421       | -0.1569       | 0.1329    | 0.0045          |
| 70             | -0.2090      | -0.295       | -0.0730      | -0.0159      | -0.0571       | 0.0663    | -0.0063         |

E. F. L = 72 ( $\pm 19.1^\circ$ )

\*\*\* 1 = 2.041, \*\*\* 2 = 28.624, \*\*\* 3 = 24.389

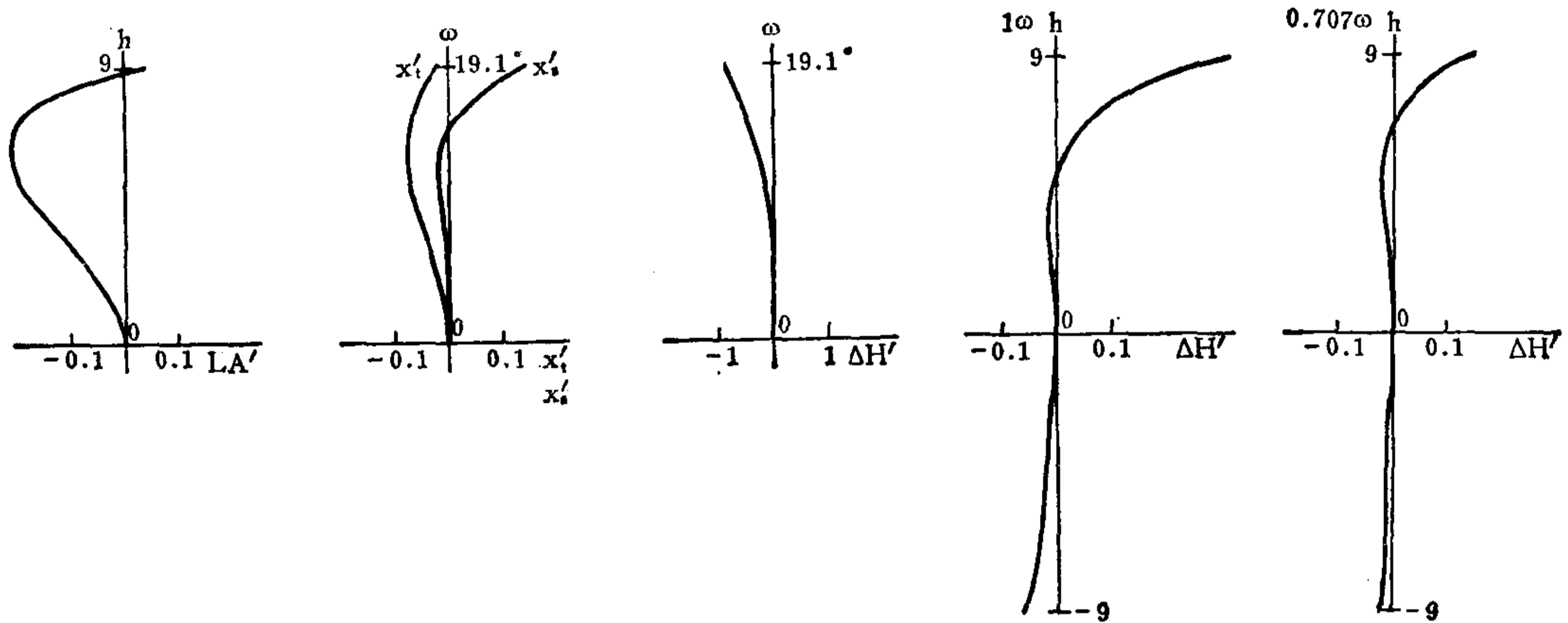

04-03-028-2

|                | $\Sigma S_1$ | $\Sigma S_2$ | $\Sigma S_3$ | $\Sigma S_4$ | $\Sigma S_5$  | HI        | QP(1 $\omega$ ) |
|----------------|--------------|--------------|--------------|--------------|---------------|-----------|-----------------|
|                | 0.00318      | -0.00248     | 0.00067      | -0.00343     | 0.18596       | 24.06     | 2.98%           |
| h 或 $\omega$ % | LA'          | $\Delta H'$  | $x'_t$       | $x'_s$       | $x'_t - x'_s$ | $K'_{T1}$ | $K'_{T0.7}$     |
| 100            | -0.1237      | 0.718        | -0.524       | 0.065        | -0.589        | 0.0403    | -0.0109         |
| 70             | 0.0056       | 0.261        | -0.113       | -0.009       | -0.104        | 0.0615    | 0.0040          |

E. F. L = 203 ( $\pm 6.8^\circ$ )

\*\*\* 1 = 47.555, \*\*\* 2 = 6.000, \*\*\* 3 = 1.500

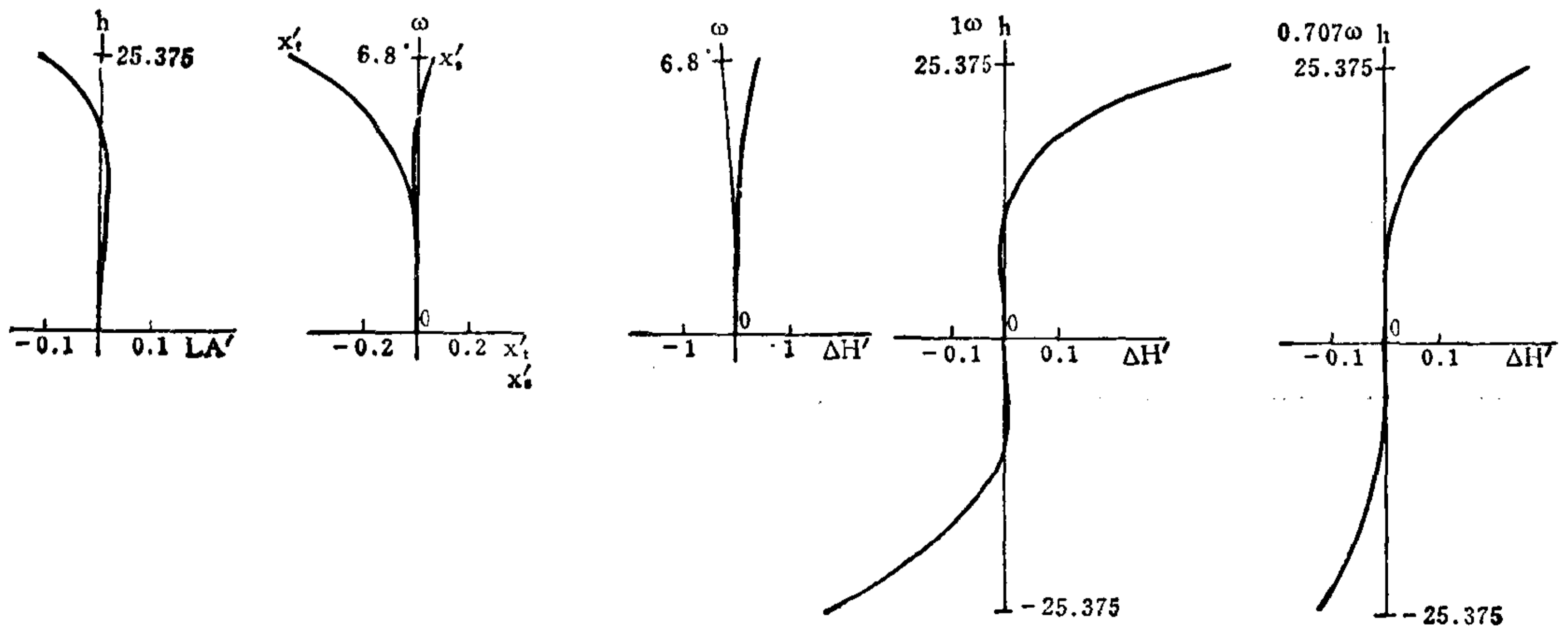



编号: 04-03-029

# 广角变焦距物镜

E. F. L = 35.99 ~ 100.00 B. F. L = 48.482 FNo. = 2.8 F. A. = ± 15.9° \*\* ~ ± 6.3° \*\*

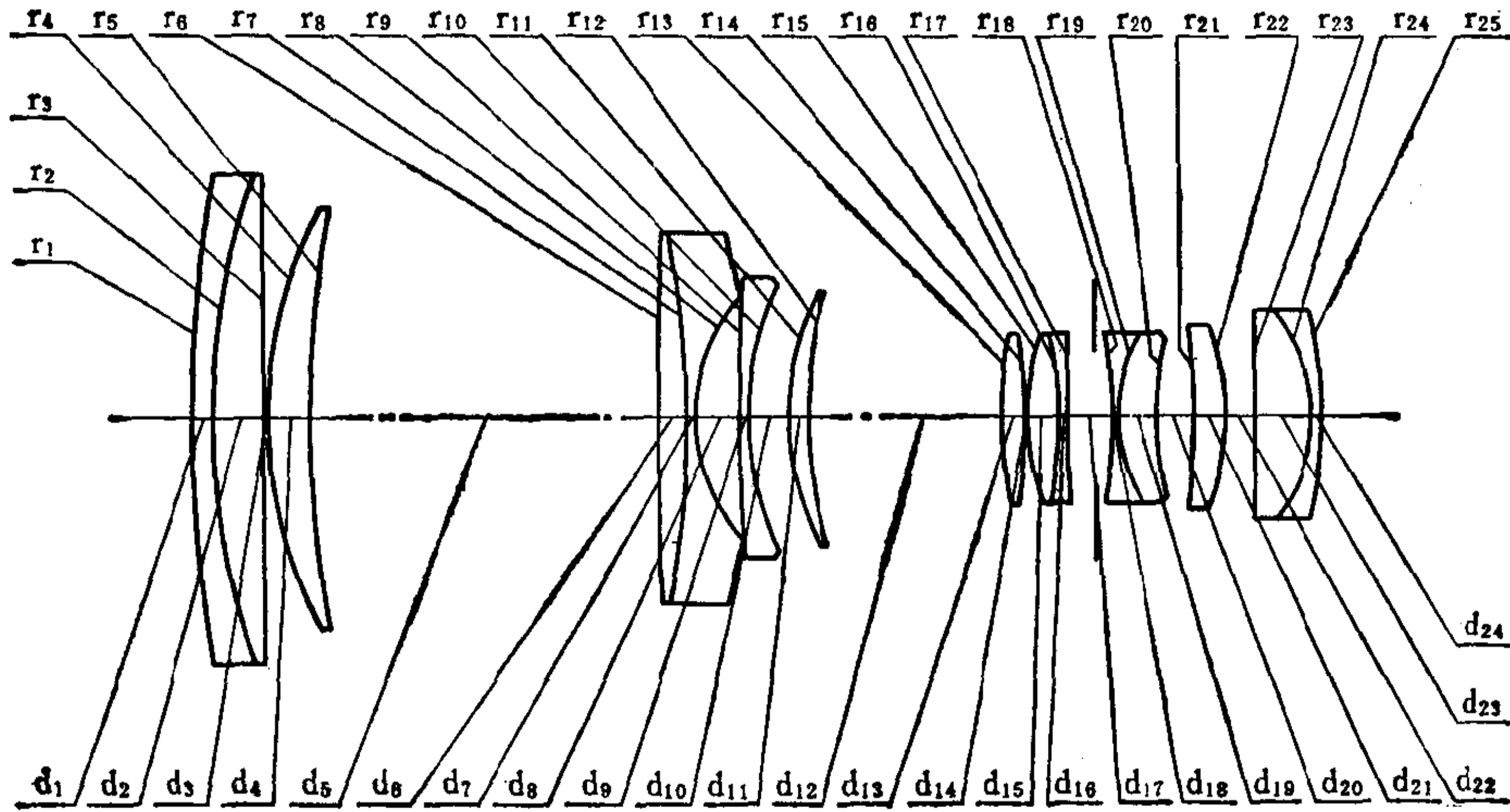

| 序号 | r        | d     | nd      | vd   | 序号 | r        | d      | nd      | vd   |
|----|----------|-------|---------|------|----|----------|--------|---------|------|
| 1  | 266.000  | 2.8   | 1.80518 | 25.5 | 14 | -86.560  | 0.1    |         |      |
| 2  | 104.500  | 7.4   | 1.64000 | 60.2 | 15 | 41.610   | 5.0    | 1.64000 | 60.2 |
| 3  | ∞        | 0.1   |         |      | 16 | -54.000  | 0.9    | 1.80518 | 25.5 |
| 4  | 64.250   | 6.5   | 1.62041 | 60.3 | 17 | 876.482  | *** 3* |         |      |
| 5  | 191.282  | *** 1 |         |      | 18 | -64.080  | 1.0    | 1.69680 | 55.6 |
| 6  | 501.010  | 3.7   | 1.80518 | 25.5 | 19 | 24.080   | 5.8    | 1.71736 | 29.5 |
| 7  | -144.785 | 1.5   | 1.67003 | 47.2 | 20 | 38.585   | 5.0    |         |      |
| 8  | 26.326   | 6.8   |         |      | 21 | -122.500 | 5.0    | 1.80610 | 41.0 |
| 9  | 470.070  | 1.5   | 1.62041 | 60.3 | 22 | -38.250  | 4.2    |         |      |
| 10 | 46.610   | 5.5   |         |      | 23 | ∞        | 8.0    | 1.75500 | 52.4 |
| 11 | 39.703   | 3.0   | 1.80518 | 25.5 | 24 | -23.770  | 1.5    | 1.75520 | 27.5 |
| 12 | 69.777   | *** 2 |         |      | 25 | -83.107  |        |         |      |
| 13 | 70.000   | 3.0   | 1.62041 | 60.3 |    |          |        |         |      |

04-03-029-1

|                | $\Sigma S_1$ | $\Sigma S_2$ | $\Sigma S_3$ | $\Sigma S_4$ | $\Sigma S_5$  | HI        | QP(1 $\omega$ ) |
|----------------|--------------|--------------|--------------|--------------|---------------|-----------|-----------------|
|                | -0.02851     | 0.00290      | 0.00188      | -0.00763     | -0.04227      | 10.2      | -1.2%           |
| h 或 $\omega$ % | LA'          | $\Delta H'$  | $x'_t$       | $x'_s$       | $x'_t - x'_s$ | $K'_{T1}$ | $K'_{T0.7}$     |
| 100            | 0.0216       | -0.1225      | -0.0353      | -0.0803      | 0.0450        | 0.0977    | 0.0221          |
| 70             | -0.1259      | -0.0435      | -0.0153      | -0.0431      | 0.0278        | 0.0836    | 0.0207          |

E. F. L = 35.99 ( $\pm 15.9^\circ$ )

\*\*\* 1 = 2.246; \*\*\* 2 = 45.122; \*\*\* 3 = 4.194; \*\*\* 3\* = 4.194 = 3.194 + 1.000

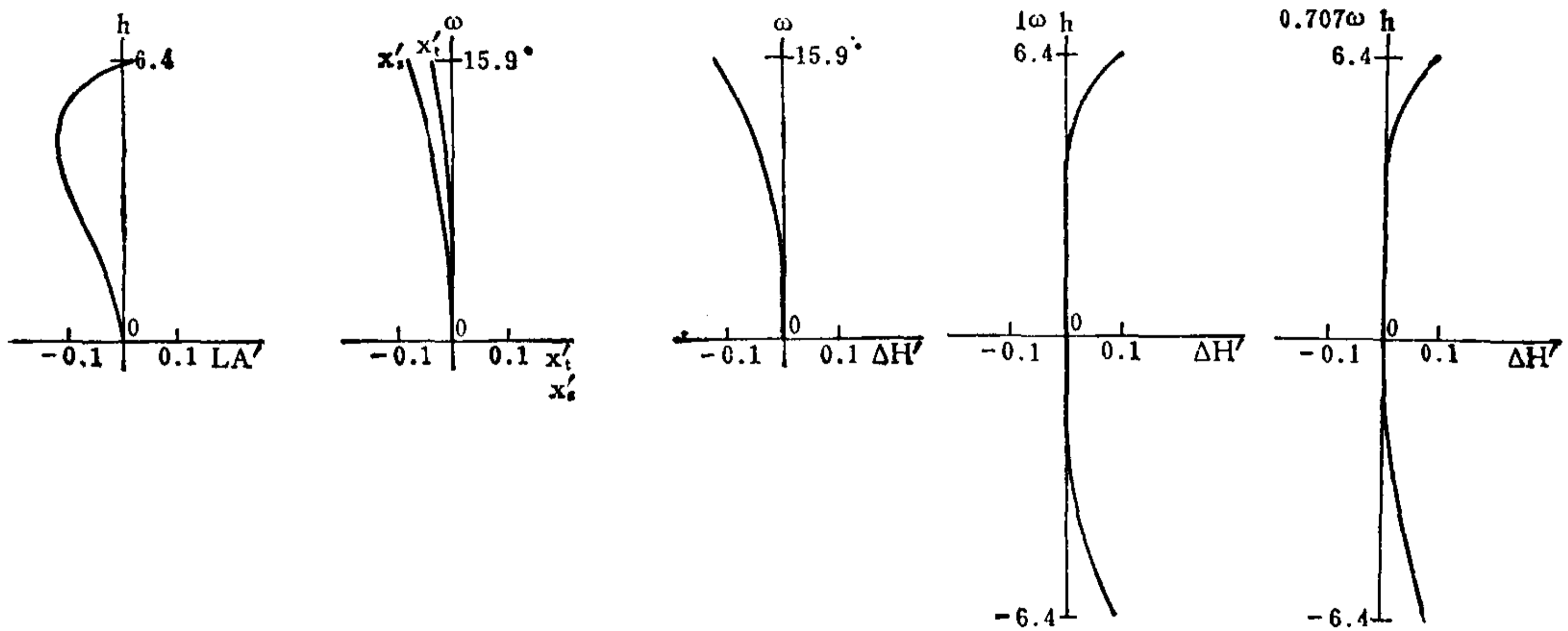

04-03-029-2

|                | $\Sigma S_1$ | $\Sigma S_2$ | $\Sigma S_3$ | $\Sigma S_4$ | $\Sigma S_5$  | HI        | QP(1 $\omega$ ) |
|----------------|--------------|--------------|--------------|--------------|---------------|-----------|-----------------|
|                | -0.02870     | -0.00627     | 0.00408      | -0.00774     | 0.00148       | 10.1      | 0.08%           |
| h 或 $\omega$ % | LA'          | $\Delta H'$  | $x'_t$       | $x'_s$       | $x'_t - x'_s$ | $K'_{T1}$ | $K'_{T0.7}$     |
| 100            | -0.0494      | 0.0084       | 0.0600       | -0.0488      | 0.1088        | 0.01513   | -0.01748        |
| 70             | -0.1422      | 0.0022       | 0.0295       | -0.0281      | 0.0576        | 0.02013   | -0.00900        |

E. F. L = 50.99 ( $\pm 11.2^\circ$ )

\*\*\* 1 = 16.246; \*\*\* 2 = 28.854; \*\*\* 3 = 6.462; \*\*\* 3\* = 6.462 = 5.462 + 1.000

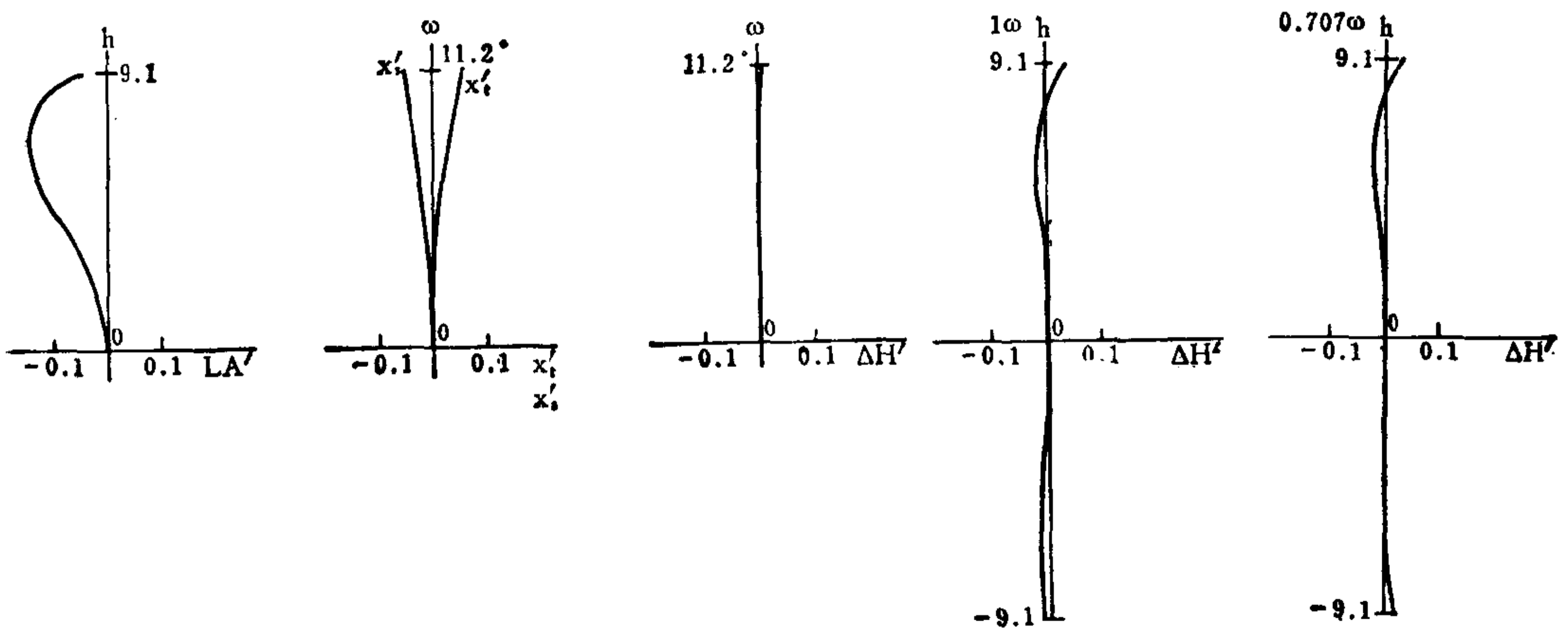

04-03-029-3

|                | $\Sigma S_1$ | $\Sigma S_2$ | $\Sigma S_3$ | $\Sigma S_4$ | $\Sigma S_5$  | HI        | QP (1 $\omega$ ) |
|----------------|--------------|--------------|--------------|--------------|---------------|-----------|------------------|
|                | 0.00971      | 0.01082      | -0.00182     | -0.00957     | 0.04095       | 11.0      | 1.1%             |
| h 或 $\omega$ % | LA'          | $\Delta H'$  | $x'_t$       | $x'_s$       | $x'_t - x'_s$ | $K'_{T1}$ | $K'_{T0.7}$      |
| 100            | -0.1480      | 0.1208       | -0.2120      | -0.1524      | -0.0596       | 0.02656   | 0.03276          |
| 70             | 0.0301       | 0.0416       | -0.1091      | -0.0822      | -0.0269       | 0.02174   | 0.02455          |

E. F. L = 100.00 ( $\pm 6.3^\circ$ )

\*\*\* 1 = 42.246; \*\*\* 2 = 0.903; \*\*\* 3 = 8.413; \*\*\* 3' = 8.413 = 7.413 + 1.000

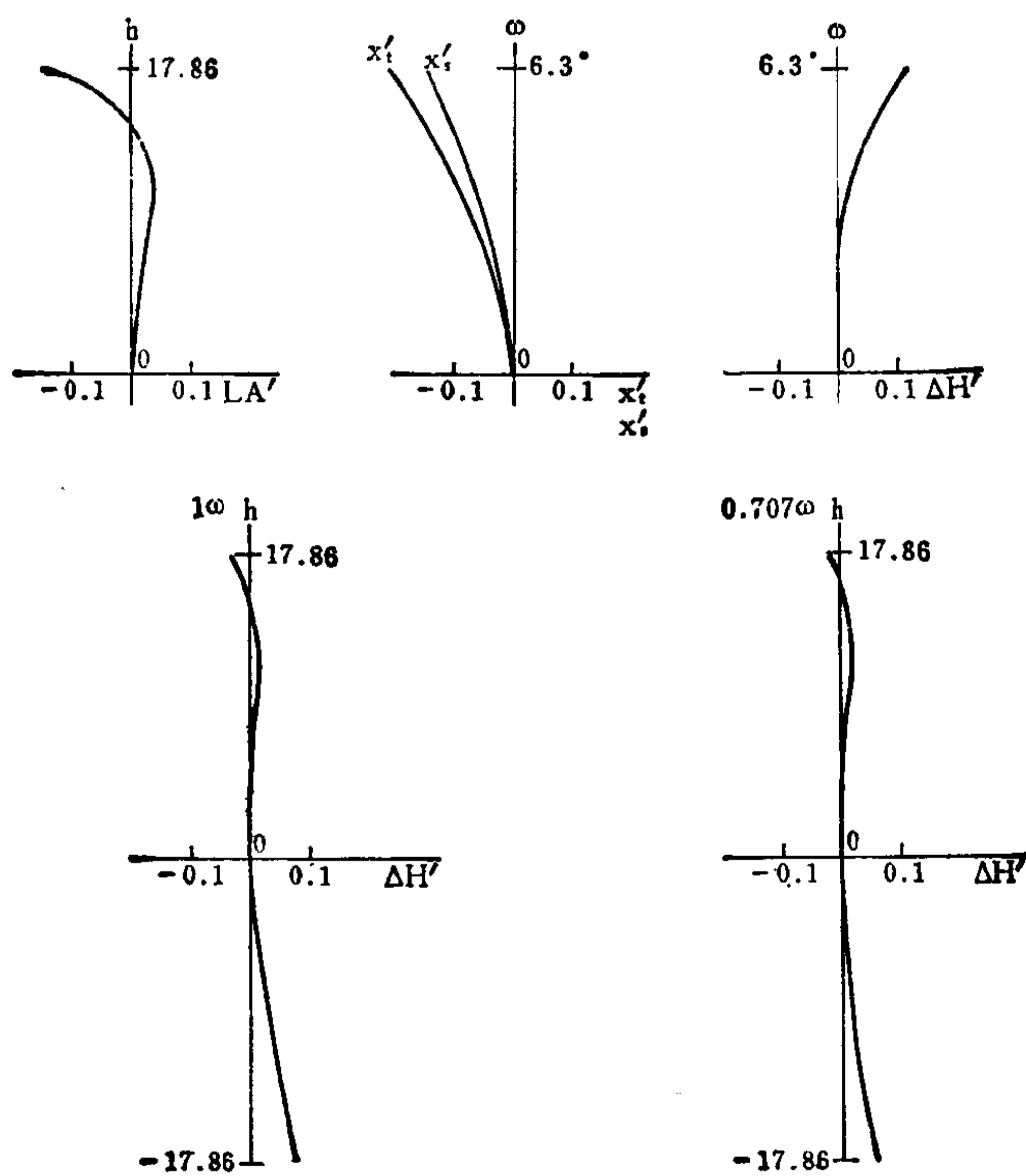

编号: 04-03-030

## 光学补偿式变焦距物镜

E.F.L = 9.50 ~ 23.00 B.F.L = 13.76 FNo. = 1.8 F.A. =  $\pm 21.1^\circ \sim \pm 8.7^\circ$

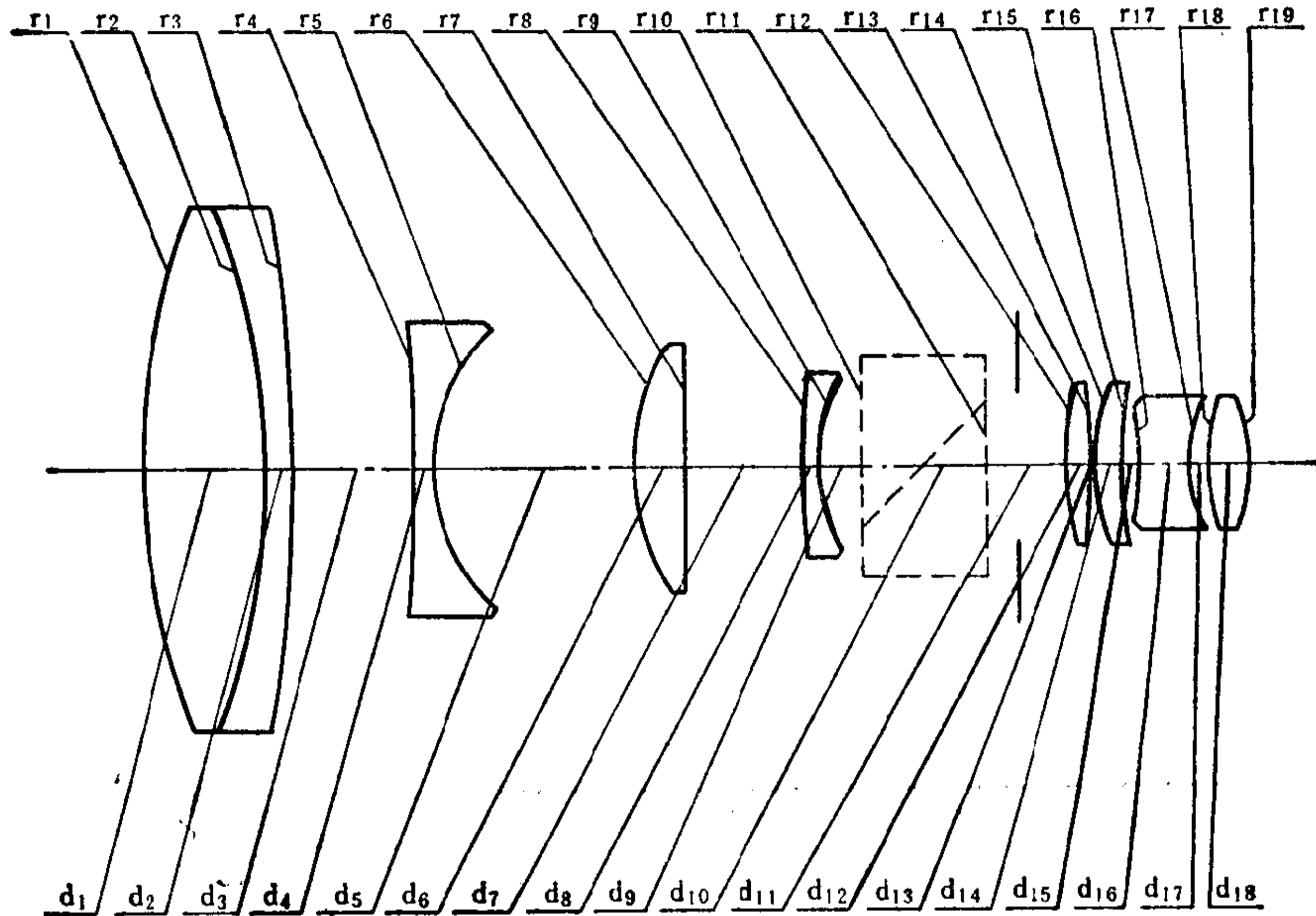

| 序号 | r        | d     | n      | v    | 序号 | r        | d     | n      | v    |
|----|----------|-------|--------|------|----|----------|-------|--------|------|
| 1  | 50.91    | 8.85  | 1.6204 | 60.3 | 11 | $\infty$ | 5.80* |        |      |
| 2  | -55.61   | 1.90  | 1.8052 | 25.5 | 12 | 22.02    | 1.92  | 1.7844 | 43.8 |
| 3  | -125.86  | *** 1 |        |      | 13 | -57.37   | 0.04  |        |      |
| 4  | -327.60  | 1.50  | 1.6204 | 60.3 | 14 | 14.49    | 2.15  | 1.7440 | 44.9 |
| 5  | 13.82    | *** 2 |        |      | 15 | 37.67    | 1.00  |        |      |
| 6  | 17.38    | 3.60  | 1.5785 | 41.7 | 16 | -27.65   | 3.90  | 1.8052 | 25.5 |
| 7  | $\infty$ | *** 3 |        |      | 17 | 9.89     | 1.30  |        |      |
| 8  | 72.09    | 1.00  | 1.6204 | 60.3 | 18 | 15.87    | 2.85  | 1.7130 | 53.9 |
| 9  | 12.44    | 3.06  |        |      | 19 | -13.58   |       |        |      |
| 10 | $\infty$ | 9.00  | 1.5168 | 64.2 |    |          |       |        |      |

5.80\* = 5.00 + 0.80

04-03-030-1

|                | $\Sigma S_1$ | $\Sigma S_2$ | $\Sigma S_3$ | $\Sigma S_4$ | $\Sigma S_5$  | HI        | QP (1 $\omega$ ) |
|----------------|--------------|--------------|--------------|--------------|---------------|-----------|------------------|
|                | -0.02944     | -0.02356     | 0.00419      | -0.01617     | -0.08638      | 3.7       | -4.7%            |
| h 或 $\omega$ % | LA'          | $\Delta H'$  | $x'_t$       | $x'_s$       | $x'_t - x'_s$ | $K'_{T1}$ | $K'_{T0.7}$      |
| 100            | -0.0189      | -0.175       | -0.0029      | -0.0700      | 0.0671        | 0.1273    | -0.0174          |
| 70             | -0.0760      | -0.061       | -0.0108      | -0.0395      | 0.0287        | 0.0787    | -0.0176          |

E. F. L = 9.52 ( $\pm 21.1^\circ$ )

\*\*\* 1 = 0.41; \*\*\* 2 = 23.10; \*\*\* 3 = 0.40

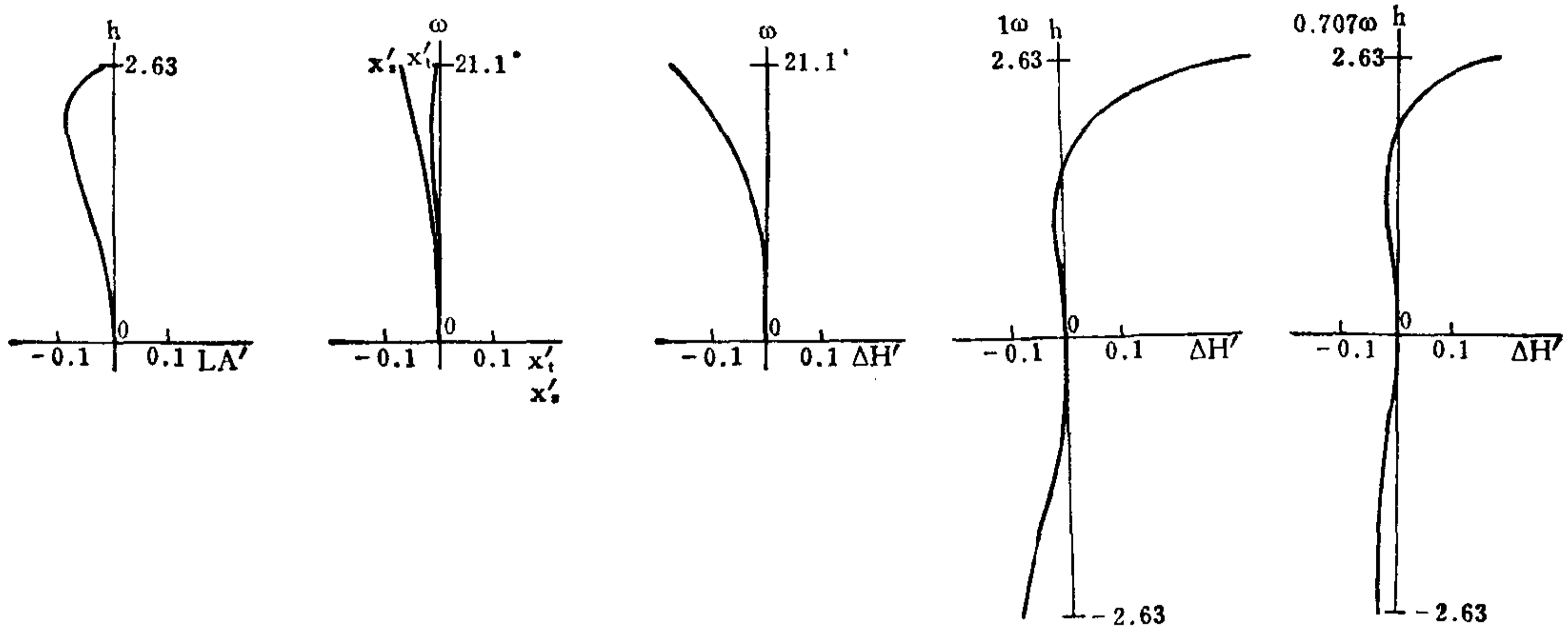

04-03-030-2

|                | $\Sigma S_1$ | $\Sigma S_2$ | $\Sigma S_3$ | $\Sigma S_4$ | $\Sigma S_5$  | HI        | QP (1 $\omega$ ) |
|----------------|--------------|--------------|--------------|--------------|---------------|-----------|------------------|
|                | -0.03369     | -0.00604     | 0.00620      | -0.01678     | -0.02263      | 3.6       | -0.9%            |
| h 或 $\omega$ % | LA'          | $\Delta H'$  | $x'_t$       | $x'_s$       | $x'_t - x'_s$ | $K'_{T1}$ | $K'_{T0.7}$      |
| 100            | -0.0655      | -0.0321      | -0.0148      | -0.0713      | 0.0565        | 0.2514    | 0.0253           |
| 70             | -0.0921      | -0.0137      | -0.0172      | -0.0413      | 0.0241        | 0.1622    | 0.0120           |

E. F. L = 15.00 ( $\pm 13.4^\circ$ )

\*\*\* 1 = 8.70; \*\*\* 2 = 14.81; \*\*\* 3 = 8.69

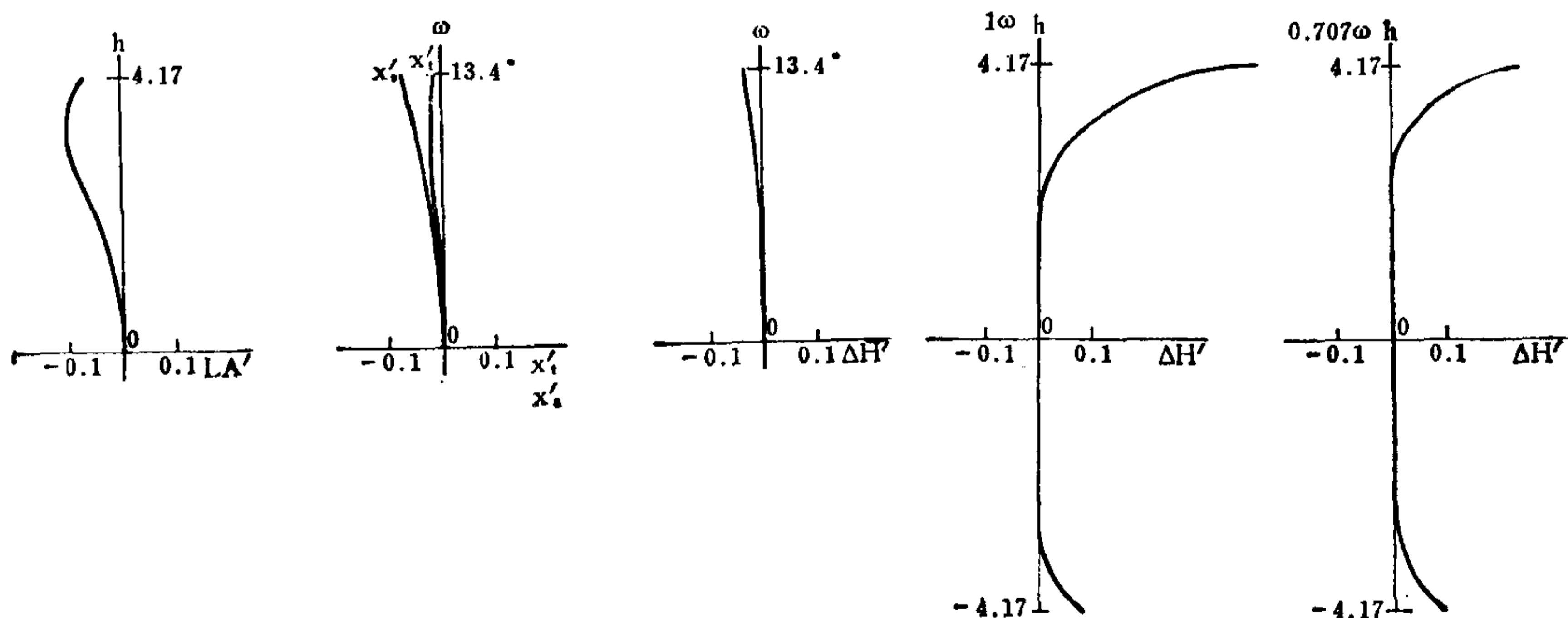

04-03-030-3

|                | $\Sigma S_1$ | $\Sigma S_2$ | $\Sigma S_3$ | $\Sigma S_4$ | $\Sigma S_5$  | HI        | QP (1 $\omega$ ) |
|----------------|--------------|--------------|--------------|--------------|---------------|-----------|------------------|
|                | -0.01177     | -0.01897     | 0.01275      | -0.01691     | 0.01869       | 3.5       | 1.7%             |
| h 或 $\omega$ % | LA'          | $\Delta H'$  | $x'_t$       | $x'_g$       | $x'_t - x'_g$ | $K'_{T1}$ | $K'_{T0.7}$      |
| 100            | 0.0840       | 0.0603       | 0.0300       | -0.0587      | 0.0887        | 0.3765    | 0.0137           |
| 70             | -0.0217      | 0.0162       | -0.0100      | -0.0395      | 0.0295        | 0.1455    | -0.0050          |

E. F. L = 23.00 ( $\pm 8.7^\circ$ )

\*\*\* 1 = 16.00; \*\*\* 2 = 7.51; \*\*\* 3 = 15.99

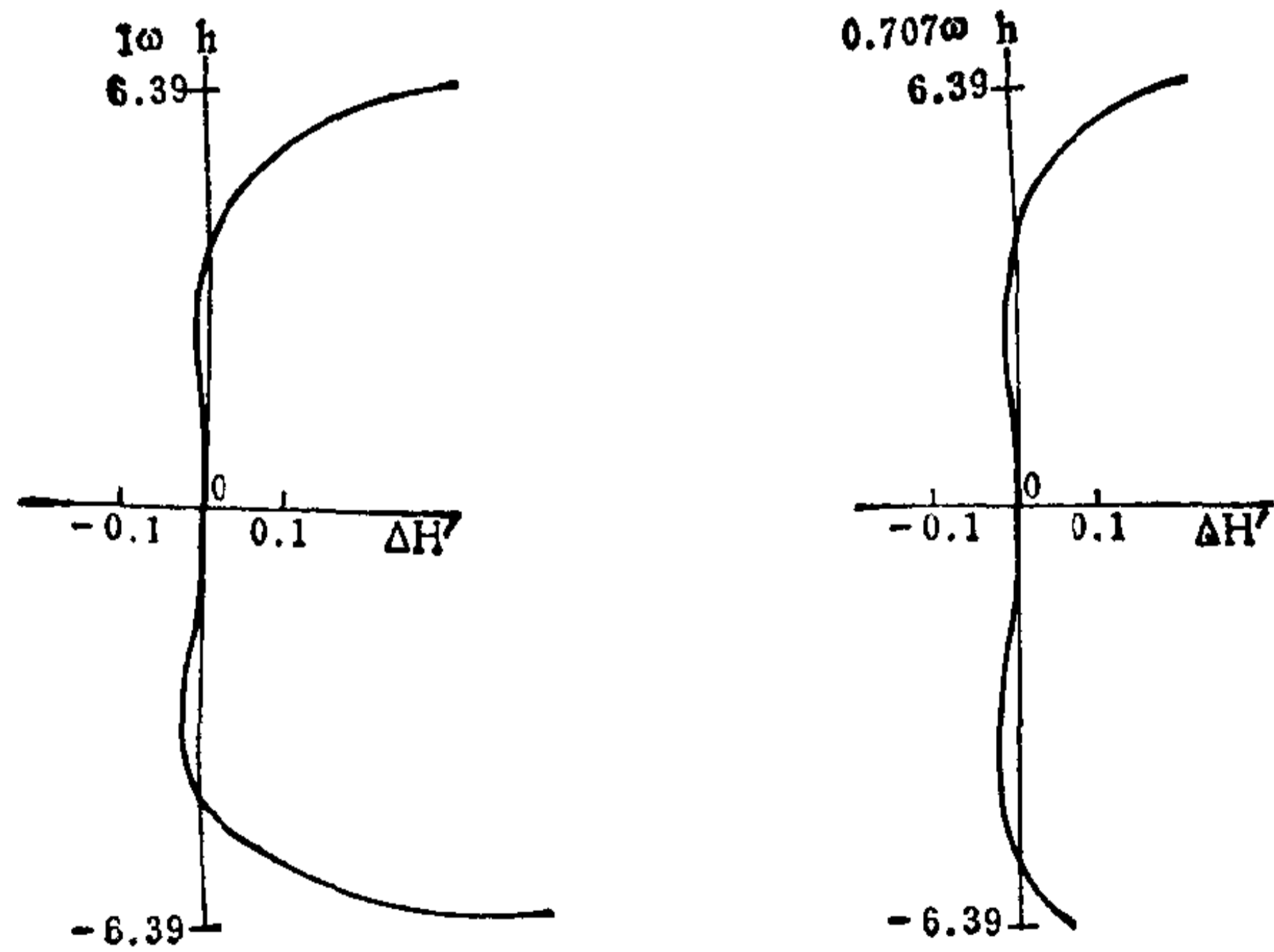
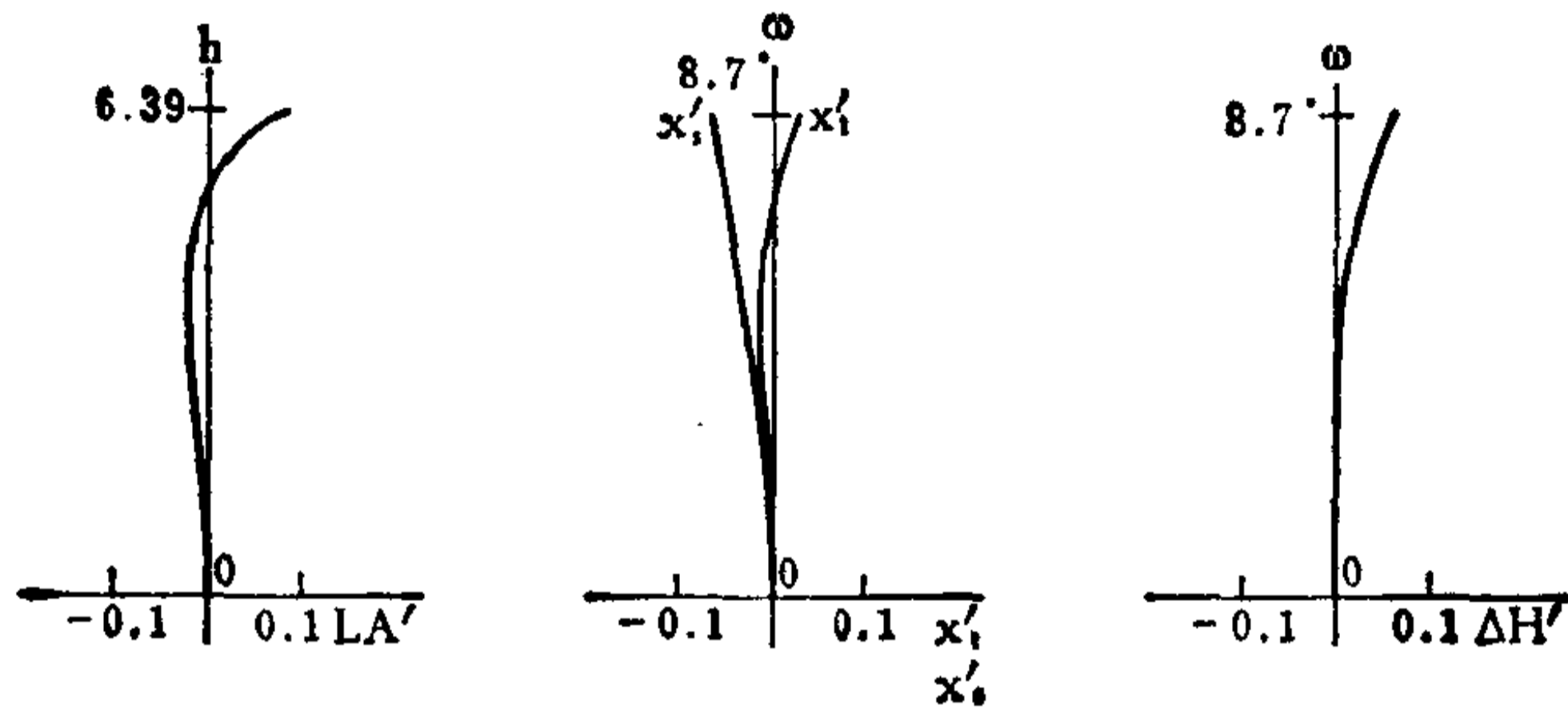

编号: 04-03-031

## 可动透镜作线性差动式移动的变焦距镜头

E.F.L=9.43~25.36 B.F.L=10.167 FNo.=2.2 F.A.=±18.22°~±6.7°

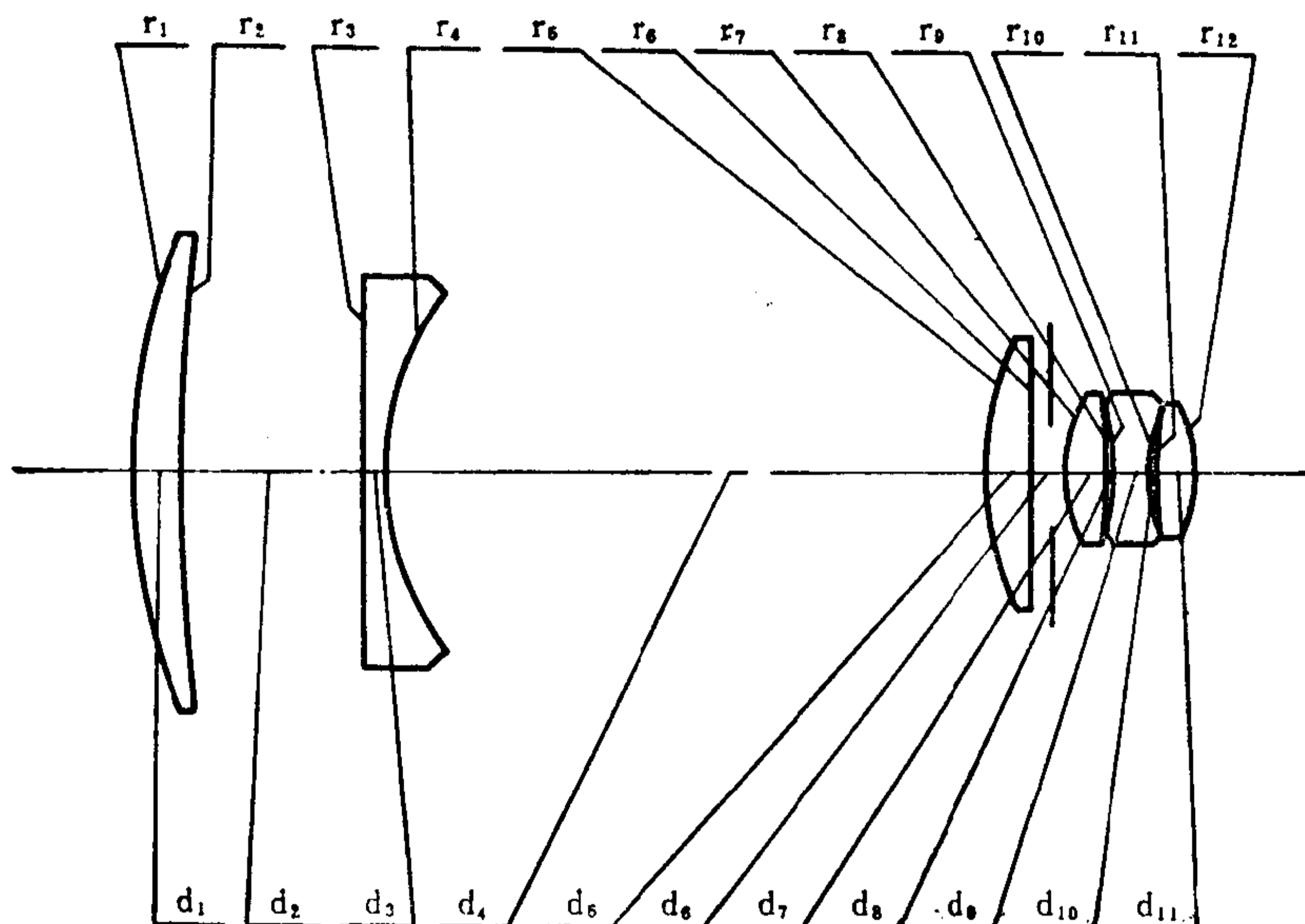

| 序号 | r       | d      | $n_D$ | $v_D$ | 序号 | r       | d     | $n_D$ | $v_D$ |
|----|---------|--------|-------|-------|----|---------|-------|-------|-------|
| 1  | 31.900  | 2.500  | 1.611 | 58.8  | 7  | 7.913   | 2.000 | 1.611 | 58.8  |
| 2  | 140.318 | *** 1  |       |       | 8  | -31.592 | 0.230 |       |       |
| 3  | ∞       | 1.000  | 1.605 | 43.6  | 9  | -11.219 | 2.000 | 1.649 | 33.8  |
| 4  | 15.212  | *** 2  |       |       | 10 | 7.985   | 0.381 |       |       |
| 5  | 19.559  | 2.000  | 1.611 | 58.8  | 11 | 31.592  | 2.000 | 1.611 | 58.8  |
| 6  | ∞       | *** 3* |       |       | 12 | -7.913  |       |       |       |

04-03-031-1

|                | $\Sigma S_1$ | $\Sigma S_2$ | $\Sigma S_3$ | $\Sigma S_4$ | $\Sigma S_5$  | HI        | QP(1 $\omega$ ) |
|----------------|--------------|--------------|--------------|--------------|---------------|-----------|-----------------|
|                | -0.01731     | -0.01522     | 0.00298      | -0.01760     | -0.04016      | 3.1       | -3.2%           |
| h 或 $\omega$ % | LA'          | $\Delta H'$  | $x'_t$       | $x'_s$       | $x'_t - x'_s$ | $K'_{T1}$ | $K'_{T0.7}$     |
| 100            | 0.0500       | -0.0985      | -0.0154      | -0.1219      | 0.1065        | -0.0060   | -0.0322         |
| 70             | -0.0448      | -0.0337      | -0.0203      | -0.0653      | 0.0450        | -0.0156   | -0.0253         |

E. F. L = 9.43 ( $\pm 18.22^\circ$ )

\*\*\* 1 = 4.677; \*\*\* 2 = 31.334; \*\*\* 3 = 2.660; \*\*\* 3\* = 2.660 = 1.644 + 1.016

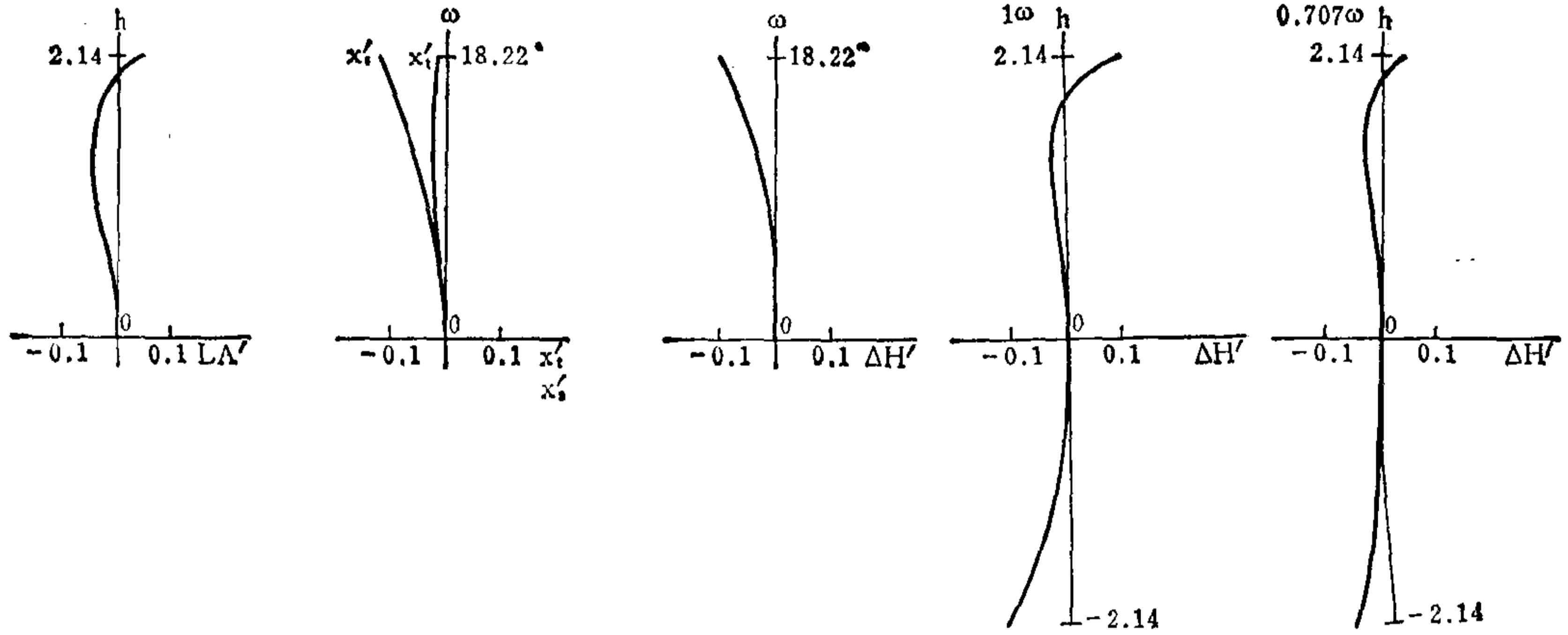

04-03-031-2

|                | $\Sigma S_1$ | $\Sigma S_2$ | $\Sigma S_3$ | $\Sigma S_4$ | $\Sigma S_5$  | HI        | QP(1 $\omega$ ) |
|----------------|--------------|--------------|--------------|--------------|---------------|-----------|-----------------|
|                | -0.00422     | -0.00832     | 0.00344      | -0.01807     | 0.02364       | 3         | 1.87%           |
| h 或 $\omega$ % | LA'          | $\Delta H'$  | $x'_t$       | $x'_s$       | $x'_t - x'_s$ | $K'_{T1}$ | $K'_{T0.7}$     |
| 100            | 0.1798       | 0.0562       | -0.0370      | -0.1358      | 0.0988        | 0.02757   | -0.0116         |
| 70             | 0.0193       | 0.0191       | -0.0317      | -0.0705      | 0.0388        | 0.00980   | -0.0109         |

E. F. L = 25.36 ( $\pm 6.7^\circ$ )

\*\*\* 1 = 18.868; \*\*\* 2 = 2.952; \*\*\* 3 = 16.851; \*\*\* 3\* = 16.851 = 15.835 + 1.016

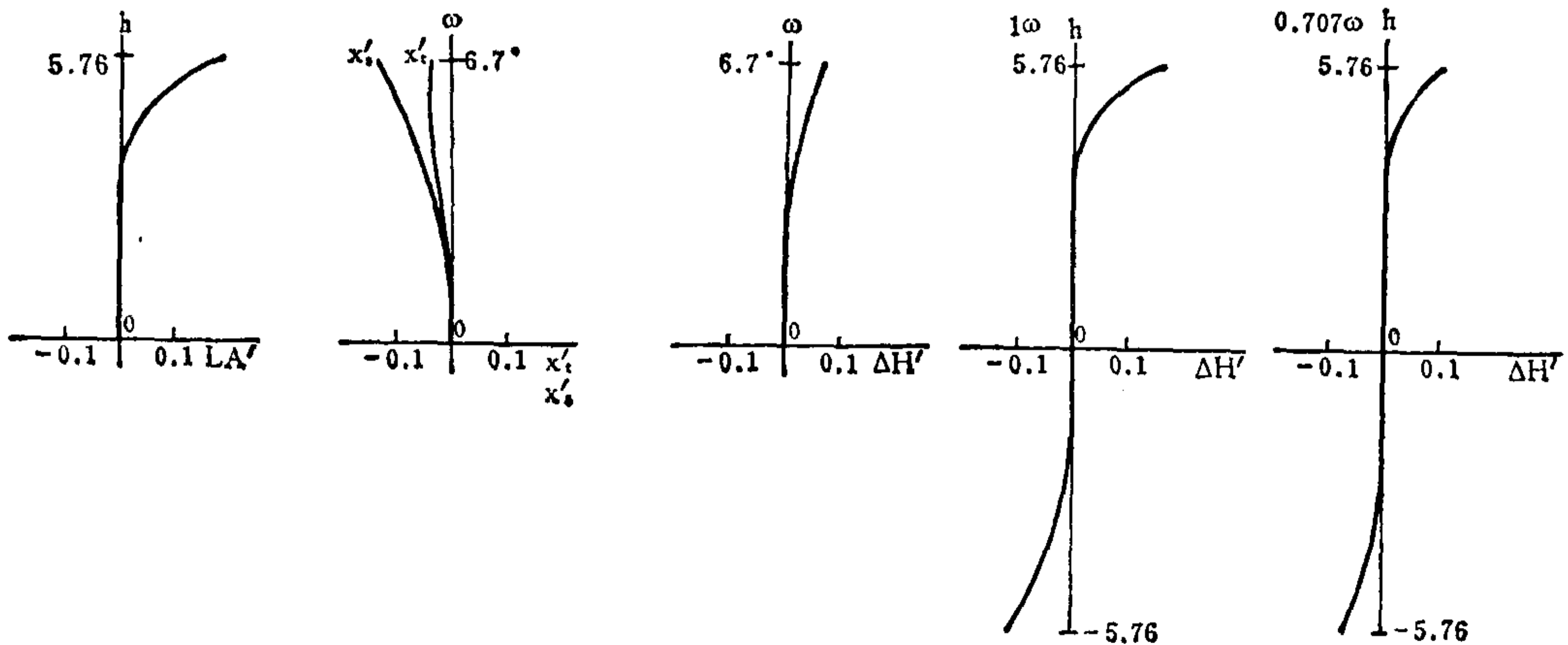



编号: 04-03-032

# 大倍率变焦距镜头

E. F. L = 60.0 ~ 400.0    B. F. L =    FNo. = 14    F. A. = ± 20° ~ ± 3.5°

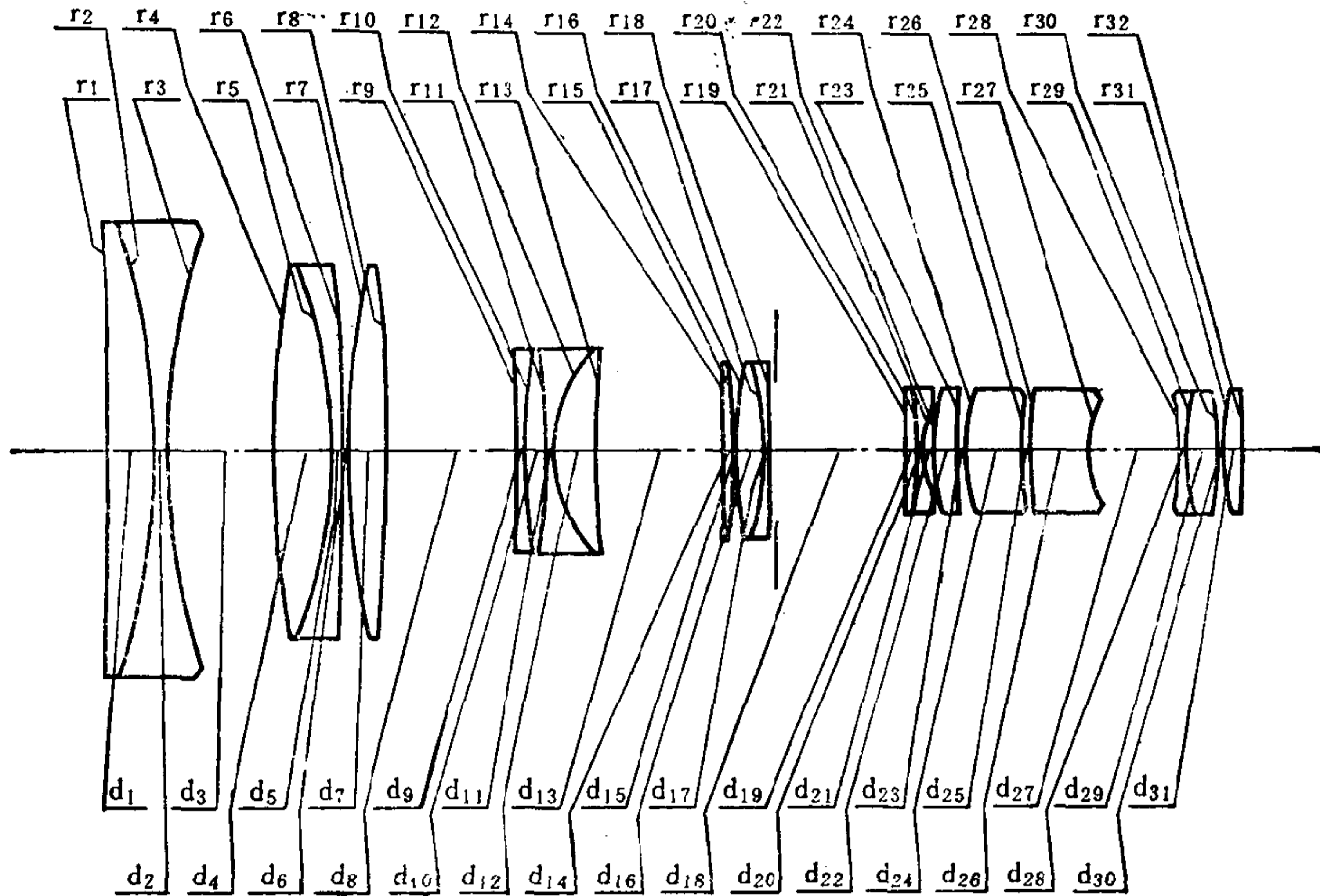

| 序号 | r         | d     | n      | v    | 序号 | r        | d     | n       | v    |
|----|-----------|-------|--------|------|----|----------|-------|---------|------|
| 1  | -1000.000 | 14.00 | 1.6645 | 35.9 | 17 | -92.227  | 2.40  | 1.6398  | 34.6 |
| 2  | -181.600  | 4.00  | 1.6228 | 56.9 | 18 | ∞        | *** 4 |         |      |
| 3  | 205.700   | *** 1 |        |      | 19 | -778.900 | 3.20  | 1.6398  | 34.6 |
| 4  | 405.000   | 16.00 | 1.6204 | 60.3 | 20 | -105.000 | 1.60  | 1.6385  | 55.5 |
| 5  | -148.240  | 3.00  | 1.6889 | 31.1 | 21 | 23.945   | 2.00  |         |      |
| 6  | -1000.000 | 0.10  |        |      | 22 | 86.700   | 8.40  | 1.62084 | 60.3 |
| 7  | 207.300   | 12.00 | 1.6204 | 60.4 | 23 | 135.000  | 0.30  |         |      |
| 8  | -683.600  | *** 2 |        |      | 24 | 55.286   | 17.25 | 1.56377 | 60.9 |
| 9  | -1000.600 | 2.50  | 1.6172 | 54.0 | 25 | 111.075  | 2.40  |         |      |
| 10 | 191.560   | 5.00  |        |      | 26 | 214.500  | 17.85 | 1.67266 | 32.0 |
| 11 | -250.000  | 2.50  | 1.6127 | 58.6 | 27 | 34.680   | 26.25 |         |      |
| 12 | 44.800    | 12.50 | 1.6128 | 37.0 | 28 | -47.300  | 0.90  | 1.57808 | 41.6 |
| 13 | 331.400   | *** 3 |        |      | 29 | 55.500   | 11.55 | 1.63867 | 55.3 |
| 14 | ∞         | 3.50  | 1.6204 | 60.3 | 30 | -55.500  | 0.30  |         |      |
| 15 | -229.400  | 0.10  |        |      | 31 | 109.500  | 4.50  | 1.61193 | 37.1 |
| 16 | 203.000   | 7.50  | 1.6204 | 60.3 | 32 | -493.500 |       |         |      |

(1) E. F. L = 60.0

\*\*\* 1 = 104.12; \*\*\* 2 = 5.96; \*\*\* 3 = 207.06; \*\*\* 4 = 20.98

(2) E. F. L = 150.0

\*\*\* 1 = 60.85; \*\*\* 2 = 104.55; \*\*\* 3 = 108.47; \*\*\* 4 = 64.25

(3) E. F. L = 400.0

\*\*\* 1 = 14.66; \*\*\* 2 = 210.62; \*\*\* 3 = 2.40; \*\*\* 4 = 110.44

编号: 04-03-033

## 小型的大倍率变焦距镜头

E.F.L = 6.5 ~ 75.0    B.F.L = 9.2330    FNo. = 1.8    F.A. =  $\pm 24^\circ \sim \pm 2.4^\circ$

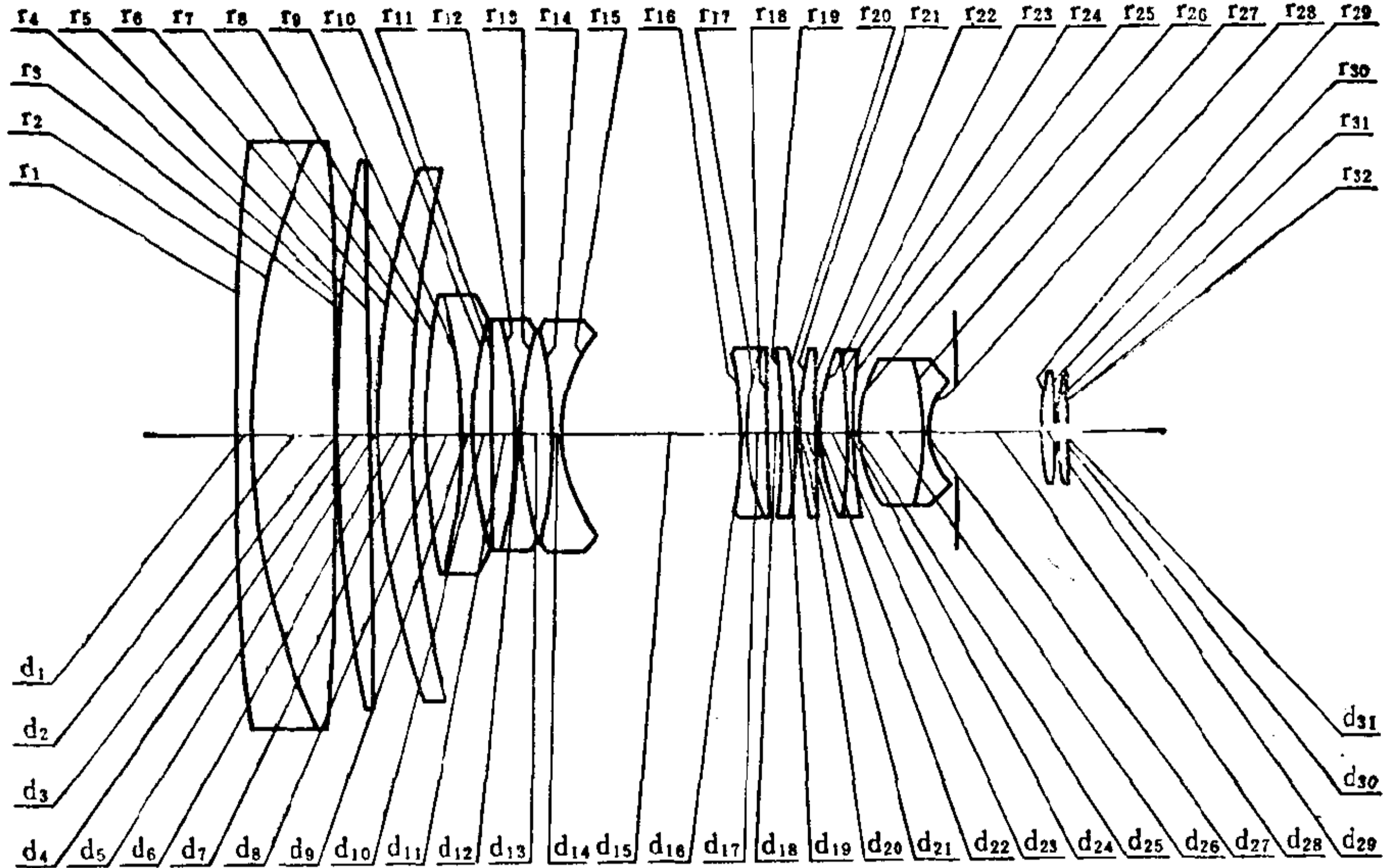

| 序号 | r         | d     | n <sub>D</sub> | v <sub>D</sub> | 序号 | r          | d     | n <sub>D</sub> | v <sub>D</sub> |
|----|-----------|-------|----------------|----------------|----|------------|-------|----------------|----------------|
| 1  | 356.9900  | 1.20  | 1.7552         | 27.5           | 17 | 18.8900    | 1.80  | 1.53256        | 46.0           |
| 2  | 61.6600   | 6.70  | 1.713          | 53.9           | 18 | -2436.8890 | *** 3 |                |                |
| 3  | -602.2800 | 0.10  |                |                | 19 | -411.2400  | 1.30  | 1.83481        | 42.9           |
| 4  | 152.4500  | 3.00  | 1.62041        | 60.3           | 20 | -38.3300   | 0.10  |                |                |
| 5  | ∞         | 0.10  |                |                | 21 | 38.3300    | 1.40  | 1.883          | 41.0           |
| 6  | 66.5400   | 3.40  | 1.62041        | 60.3           | 22 | 450.3700   | 0.10  |                |                |
| 7  | 178.9310  | *** 1 |                |                | 23 | 17.2100    | 2.50  | 1.58313        | 59.3           |
| 8  | 92.9800   | 2.90  | 1.80518        | 25.5           | 24 | -54.5700   | 0.60  | 1.78472        | 25.7           |
| 9  | -46.0700  | 0.60  | 1.78595        | 50.6           | 25 | 41.0900    | 0.10  |                |                |
| 10 | 30.0000   | 1.70  |                |                | 26 | 10.4000    | 5.65  | 1.6393         | 45.0           |
| 11 | ∞         | 2.00  | 1.80518        | 25.5           | 27 | -25.0500   | 0.50  | 1.69895        | 30.0           |
| 12 | -43.8000  | 0.60  | 1.78595        | 50.6           | 28 | 6.9100     | 9.60  |                |                |
| 13 | 36.7300   | 2.50  |                |                | 29 | 20.8900    | 1.00  | 1.62041        | 60.3           |
| 14 | -36.7300  | 0.60  | 1.62041        | 60.3           | 30 | -99.6200   | 0.10  |                |                |
| 15 | 14.2833   | *** 2 |                |                | 31 | 23.9400    | 1.00  | 1.62041        | 60.3           |
| 16 | -24.4800  | 0.60  | 1.51633        | 64.1           | 32 | ∞          |       |                |                |

(1) E.F.L = 6.5

\*\*\* 1 = 1.152; \*\*\* 2 = 51.597; \*\*\* 3 = 1.000

(2) E.F.L = 30.0

\*\*\* 1 = 38.364; \*\*\* 2 = 7.091; \*\*\* 3 = 8.294

(3) E.F.L = 75.0

\*\*\* 1 = 49.553; \*\*\* 2 = 3.196; \*\*\* 3 = 1.000

编号: 04-03-034

# 变 焦 距 镜 头

E. F. L = 7.0 ~ 56.0

B. F. L =

FNo. = 1.8

F. A. =

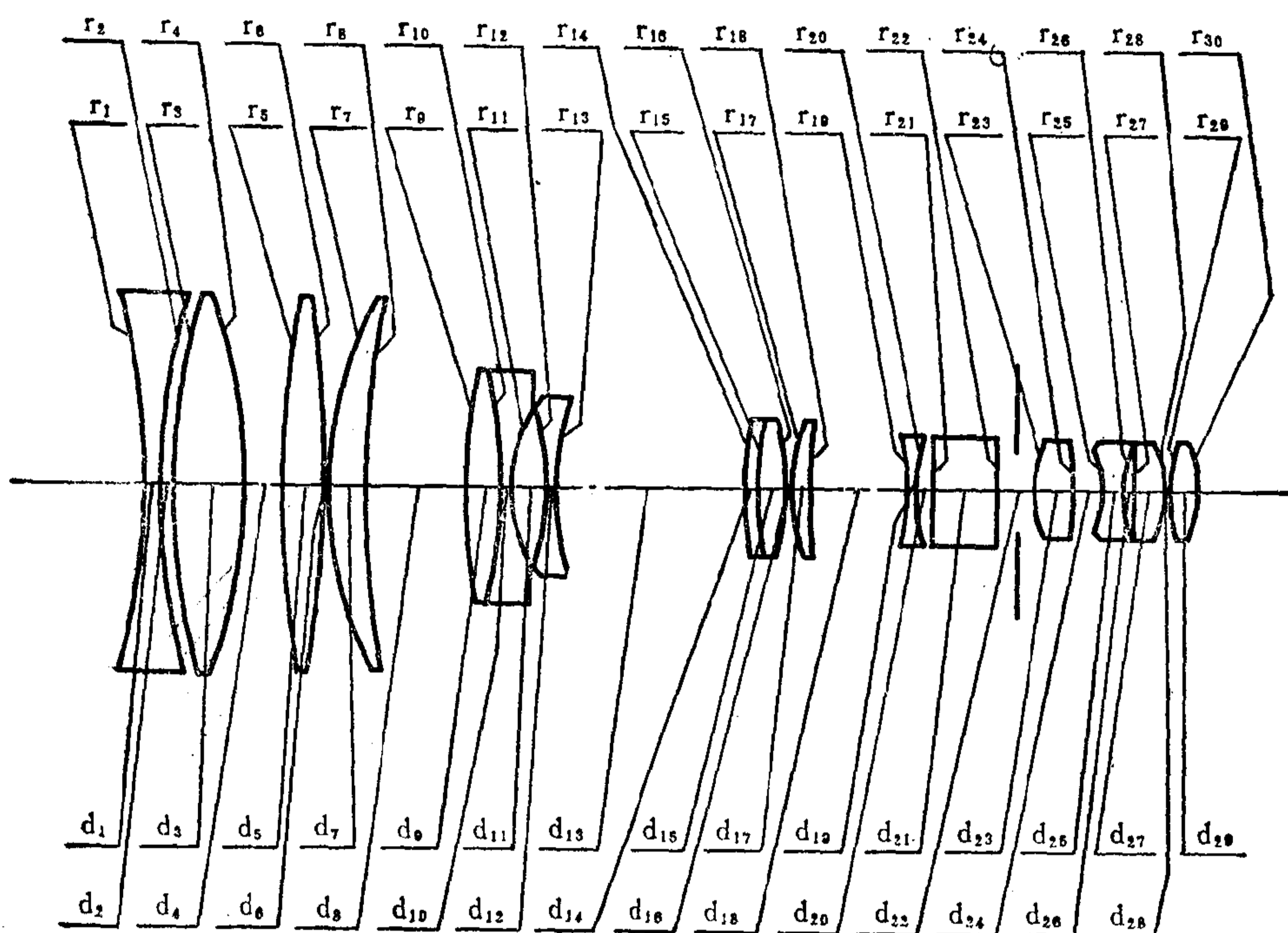

| 序号 | r      | d     | n     | v    | 序号 | r      | d     | n     | v    |
|----|--------|-------|-------|------|----|--------|-------|-------|------|
| 1  | -67.2  | 1.90  | 1.805 | 25.4 | 16 | -30.0  | 0.10  |       |      |
| 2  | 105.0  | 1.90  |       |      | 17 | 19.9   | 2.70  | 1.720 | 50.4 |
| 3  | 116.0  | 8.30  | 1.574 | 56.4 | 18 | 78.2   | *** 3 |       |      |
| 4  | -60.8  | 4.90  |       |      | 19 | -41.1  | 0.90  | 1.620 | 60.3 |
| 5  | 187.0  | 4.40  | 1.643 | 48.0 | 20 | 17.4   | 1.90  |       |      |
| 6  | -187.0 | 0.10  |       |      | 21 | ∞      | 8.20  | 1.569 | 56.1 |
| 7  | 45.4   | 5.70  | 1.658 | 50.9 | 22 | ∞      | 5.05  |       |      |
| 8  | 166.0  | *** 1 |       |      | 23 | 17.8   | 4.20  | 1.570 | 49.5 |
| 9  | 93.2   | 3.80  | 1.805 | 25.4 | 24 | -49.7  | 3.50  |       |      |
| 10 | -52.2  | 1.00  | 1.620 | 60.3 | 25 | -16.5  | 2.40  | 1.847 | 23.8 |
| 11 | 16.6   | 4.90  |       |      | 26 | 16.5   | 1.35  |       |      |
| 12 | -37.9  | 1.00  | 1.744 | 44.8 | 27 | -585.0 | 3.80  | 1.569 | 63.1 |
| 13 | 41.2   | *** 2 |       |      | 28 | -12.4  | 0.20  |       |      |
| 14 | 77.7   | 0.80  | 1.741 | 27.6 | 29 | 18.9   | 3.10  | 1.620 | 60.3 |
| 15 | 30.0   | 3.80  | 1.652 | 44.9 | 30 | -23.3  |       |       |      |

(1) E. F. L = 7.0

\*\*\* 1 = 0.80; \*\*\* 2 = 41.80; \*\*\* 3 = 2.80

(2) E. F. L = 56.0

\*\*\* 1 = 29.30; \*\*\* 2 = 2.00; \*\*\* 3 = 14.10

编号: 04-03-035

# 变焦距电影摄影镜头

E.F.L = 8~24

B.F.L =

FNo. = 1.6

F.A. = ± 37.5°

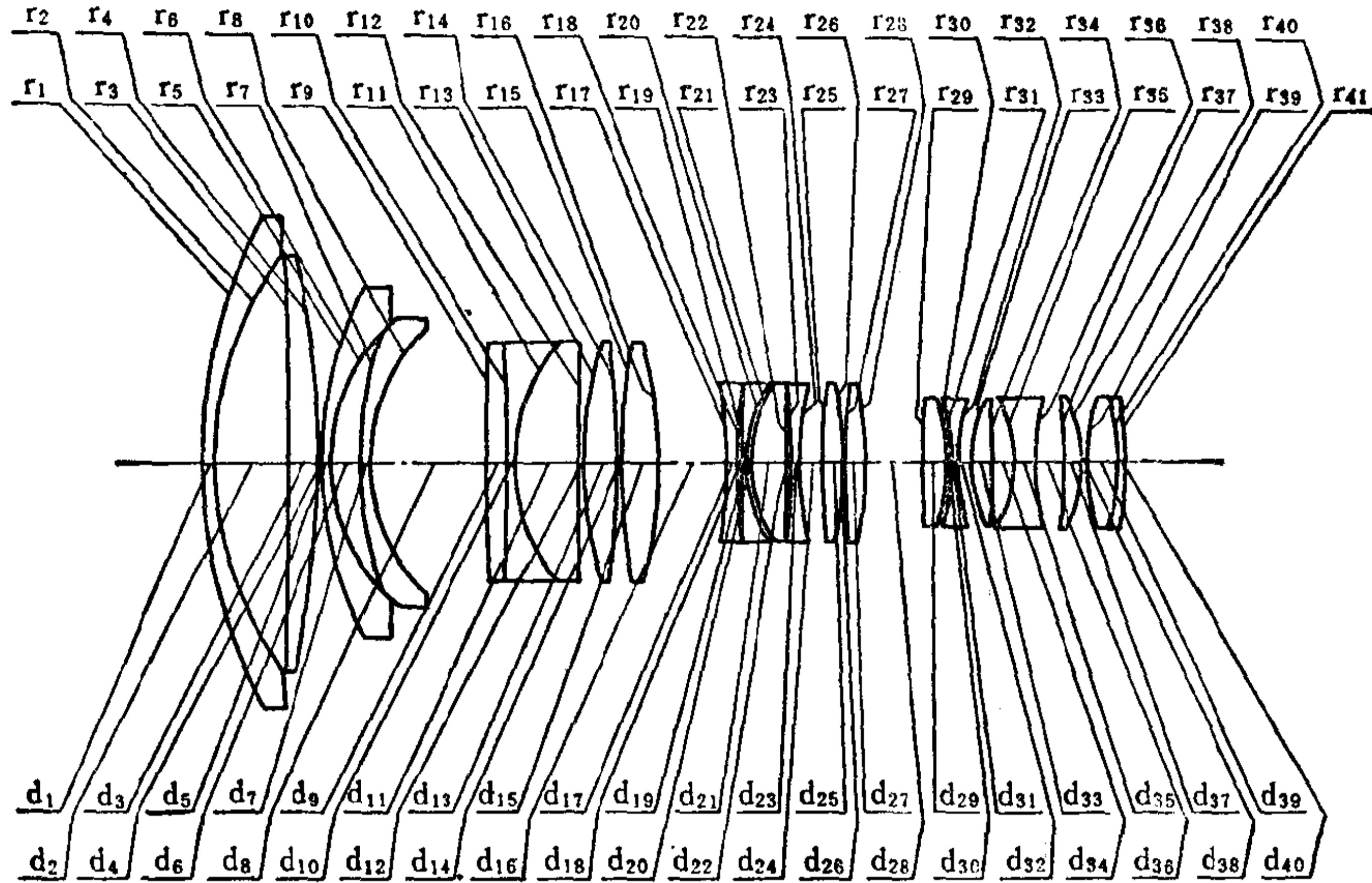

| 序号 | r       | d     | n <sub>d</sub> | v <sub>d</sub> | 序号 | r       | d     | n <sub>d</sub> | v <sub>d</sub> |
|----|---------|-------|----------------|----------------|----|---------|-------|----------------|----------------|
| 1  | 76.20   | 2.20  | 1.697          | 56             | 22 | ∞       | 0.40  |                |                |
| 2  | 55.20   | 11.10 |                |                | 23 | -170.60 | 1.40  | 1.697          | 56             |
| 3  | -740.80 | 4.40  | 1.697          | 36             | 24 | 50.00   | *** 3 |                |                |
| 4  | -145.50 | 0.20  |                |                | 25 | 159.40  | 2.60  | 1.696          | 31             |
| 5  | 62.40   | 1.40  | 1.697          | 56             | 26 | -71.30  | 0.02  |                |                |
| 6  | 28.20   | 4.60  |                |                | 27 | 159.40  | 2.60  | 1.696          | 31             |
| 7  | 55.70   | 1.40  | 1.697          | 56             | 28 | -71.30  | *** 4 |                |                |
| 8  | 26.80   | *** 1 |                |                | 29 | 221.30  | 3.40  | 1.788          | 47             |
| 9  | 435.60  | 3.00  | 1.788          | 47             | 30 | -30.00  | 0.40  |                |                |
| 10 | -463.40 | 1.40  | 1.788          | 25             | 31 | -30.00  | 1.30  | 1.788          | 25             |
| 11 | 26.60   | 9.40  | 1.744          | 45             | 32 | 37.54   | 1.40  |                |                |
| 12 | ∞       | 0.03  |                |                | 33 | 18.60   | 3.40  | 1.720          | 50             |
| 13 | 65.00   | 5.10  | 1.697          | 56             | 34 | -528.50 | 3.10  |                |                |
| 14 | -191.20 | 1.30  |                |                | 35 | -19.45  | 3.40  | 1.788          | 25             |
| 15 | 191.20  | 5.10  | 1.697          | 56             | 36 | 33.70   | 3.80  |                |                |
| 16 | -65.00  | *** 2 |                |                | 37 | -136.40 | 3.10  | 1.720          | 50             |
| 17 | -50.00  | 1.40  | 1.697          | 56             | 38 | -18.80  | 0.13  |                |                |
| 18 | 170.60  | 0.50  |                |                | 39 | 27.50   | 4.40  | 1.697          | 56             |
| 19 | ∞       | 0.80  | 1.788          | 47             | 40 | -33.20  | 1.00  | 1.696          | 31             |
| 20 | 20.10   | 0.07  |                |                | 41 | -123.60 |       |                |                |
| 21 | 20.10   | 5.40  | 1.788          | 25             |    |         |       |                |                |

(1) E.F.L = 8

\*\*\* 1 = 18.20; \*\*\* 2 = 25.50; \*\*\* 3 = 1.70; \*\*\* 4 = 15.70

(2) E.F.L = 24

\*\*\* 1 = 29.20; \*\*\* 2 = 1.54; \*\*\* 3 = 25.70; \*\*\* 4 = 4.70



编号: 04-03-036

# 变 焦 距 镜 头

E. F. L = 12 ~ 120

B. F. L = 27.34

FNo. = 2

F. A. =

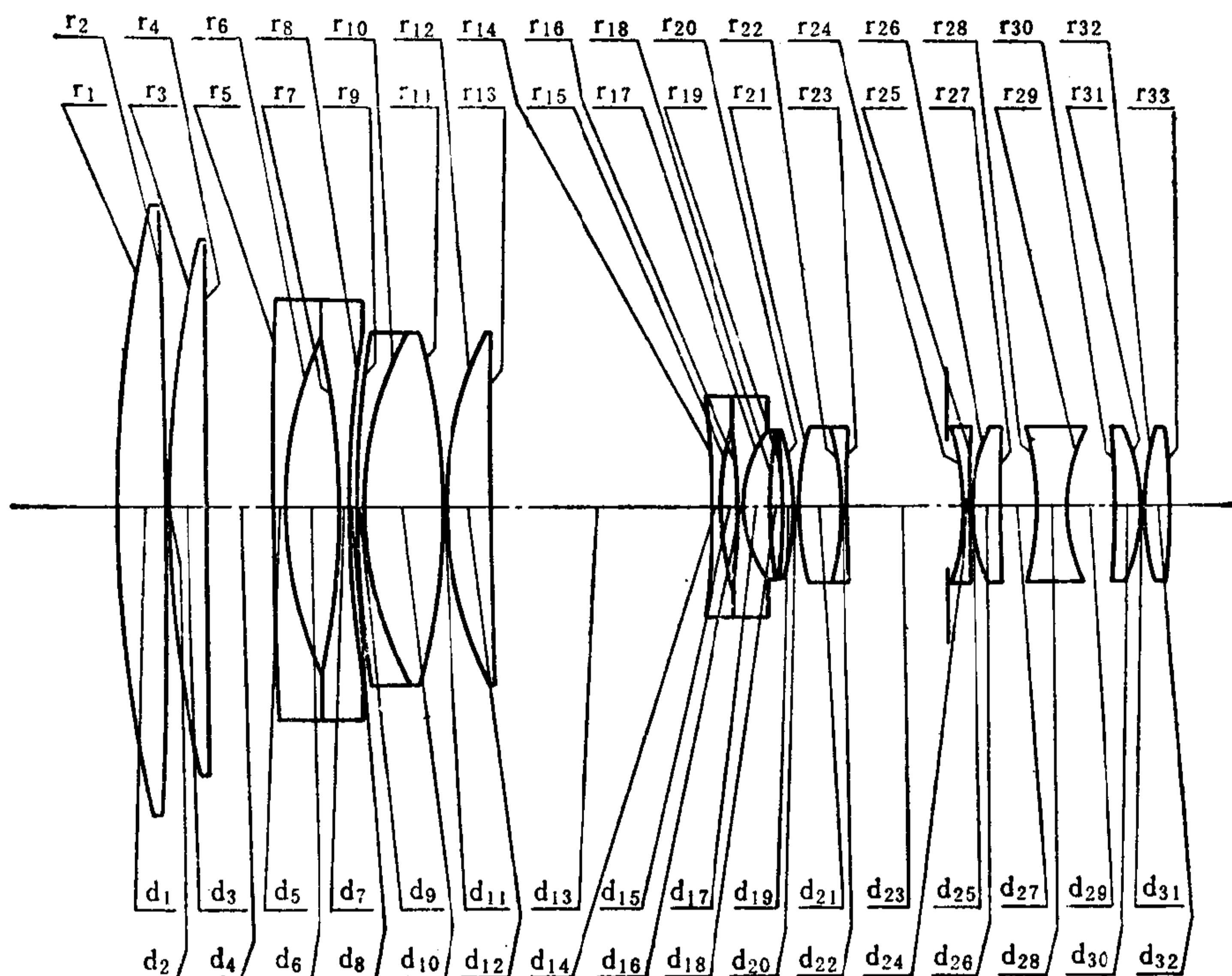

| 序号 | r        | d     | n <sub>d</sub> | v <sub>d</sub> | 序号 | r        | d     | n <sub>d</sub> | v <sub>d</sub> |
|----|----------|-------|----------------|----------------|----|----------|-------|----------------|----------------|
| 1  | 246.920  | 7.00  | 1.69738        | 56             | 18 | 65.150   | *** 3 |                |                |
| 2  | -450.780 | 0.01  |                |                | 19 | -167.150 | 2.00  | 1.51610        | 64.2           |
| 3  | 170.630  | 5.50  | 1.69930        | 30.1           | 20 | -37.950  | 0.01  |                |                |
| 4  | 4511.000 | 10.20 |                |                | 21 | 44.500   | 6.50  | 1.62008        | 60.2           |
| 5  | 856.170  | 1.50  | 1.69738        | 56             | 22 | -45.493  | 0.80  | 1.69866        | 30.1           |
| 6  | 61.110   | 8.45  |                |                | 23 | 754.200  | *** 4 |                |                |
| 7  | -117.200 | 1.50  | 1.69738        | 56             | 24 | -38.550  | 1.00  | 1.54125        | 47.6           |
| 8  | 173.000  | *** 1 |                |                | 25 | 692.200  | 0.10  |                |                |
| 9  | 184.650  | 1.00  | 1.78723        | 24.4           | 26 | 27.514   | 4.23  | 1.744          | 45             |
| 10 | 55.040   | 12.00 | 1.62086        | 60             | 27 | 983.600  | 5.36  |                |                |
| 11 | -97.750  | 0.01  |                |                | 28 | -47.400  | 4.94  | 1.73150        | 28             |
| 12 | 57.526   | 6.50  | 1.69738        | 56             | 29 | 25.611   | 6.61  |                |                |
| 13 | 2954.000 | *** 2 |                |                | 30 | -182.770 | 4.34  | 1.69675        | 56             |
| 14 | -150.700 | 0.80  | 1.62030        | 60.2           | 31 | -26.238  | 0.10  |                |                |
| 15 | 47.314   | 2.40  |                |                | 32 | 44.100   | 3.50  | 1.69675        | 56             |
| 16 | -103.060 | 0.70  | 1.69774        | 55.7           | 33 | -143.600 |       |                |                |
| 17 | 18.544   | 4.00  | 1.73118        | 28.3           |    |          |       |                |                |

(1) E. F. L = 12

\*\*\* 1 = 0.909; \*\*\* 2 = 63.243; \*\*\* 3 = 1.787; \*\*\* 4 = 32.030

(2) E. F. L = 120

\*\*\* 1 = 29.439; \*\*\* 2 = 1.247; \*\*\* 3 = 63.783; \*\*\* 4 = 3.500

编号: 04-03-037

# 大倍率大孔径变焦距物镜

E. F. L = 1.0 ~ 29.6

B. F. L = 0.162

FNo. = 2.1

F. A. =

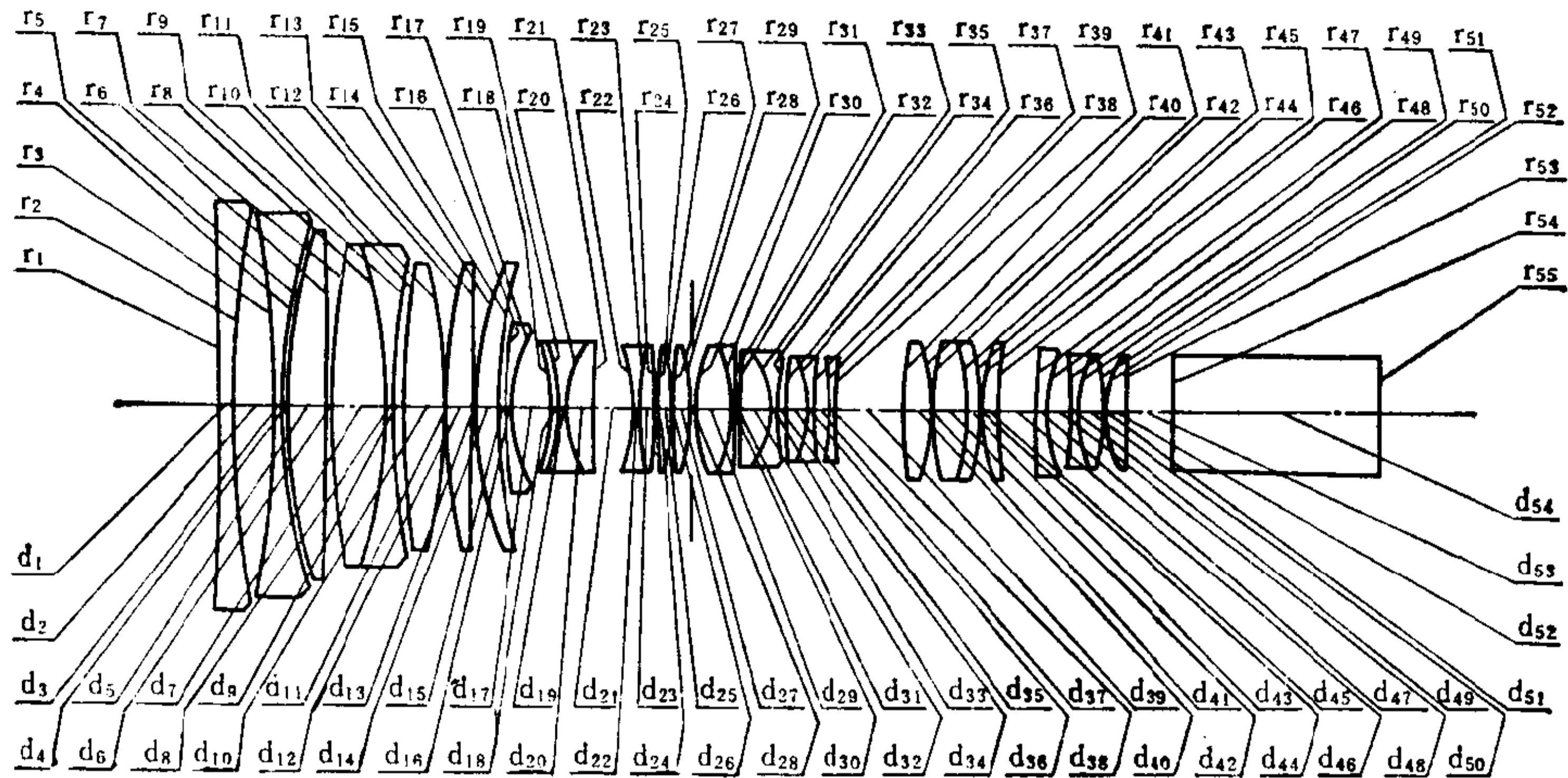

| 序号 | r       | d     | $n_e$ | $v_e$ | 序号 | r        | d     | $n_e$ | $v_e$ |
|----|---------|-------|-------|-------|----|----------|-------|-------|-------|
| 1  | -50.68  | 0.19  | 1.643 | 59.9  | 29 | 2.32     | 0.52  | 1.499 | 66.8  |
| 2  | 13.02   | 0.66  |       |       | 30 | -3.34    | 0.09  | 1.761 | 27.4  |
| 3  | -17.36  | 0.19  | 1.643 | 59.9  | 31 | -55.07   | *** 4 |       |       |
| 4  | 9.14    | 0.02  |       |       | 32 | -98.52   | 0.49  | 1.761 | 27.4  |
| 5  | 8.98    | 0.63  | 1.694 | 31.0  | 33 | -1.53    | 0.07  | 1.734 | 28.5  |
| 6  | -105.91 | 0.14  |       |       | 34 | 3.71     | *** 5 |       |       |
| 7  | 17.61   | 0.82  | 1.680 | 54.9  | 35 | 7.39     | 0.33  | 1.761 | 27.4  |
| 8  | -7.48   | 0.18  | 1.791 | 25.9  | 36 | -2.06    | 0.09  | 1.792 | 47.2  |
| 9  | 16.44   | 0.15  |       |       | 37 | 3.62     | 0.22  |       |       |
| 10 | 42.11   | 0.60  | 1.643 | 59.9  | 38 | -7.29    | 0.09  | 1.792 | 47.2  |
| 11 | -8.73   | 0.00  |       |       | 39 | 4.67     | *** 6 |       |       |
| 12 | 9.87    | 0.47  | 1.613 | 59.9  | 40 | 12.23    | 0.39  | 1.489 | 70.2  |
| 13 | -147.78 | 0.00  |       |       | 41 | -3.86    | 0.00  |       |       |
| 14 | 5.13    | 0.44  | 1.643 | 59.9  | 42 | 4.19     | 0.59  | 1.489 | 70.2  |
| 15 | 9.59    | *** 1 |       |       | 43 | -3.20    | 0.14  | 1.694 | 31.0  |
| 16 | 6.02    | 0.12  | 1.792 | 47.2  | 44 | -5.34    | 0.00  |       |       |
| 17 | 2.21    | 0.59  |       |       | 45 | 2.21     | 0.36  | 1.489 | 70.2  |
| 18 | -3.95   | 0.19  | 1.761 | 27.4  | 46 | 11.44    | 0.59  |       |       |
| 19 | -2.37   | 0.09  | 1.716 | 53.6  | 47 | 35.56    | 0.14  | 1.792 | 47.2  |
| 20 | 1.92    | 0.44  | 1.723 | 29.3  | 48 | 2.09     | 0.34  |       |       |
| 21 | 19.16   | *** 2 |       |       | 49 | -25.81   | 0.12  | 1.792 | 47.2  |
| 22 | -2.35   | 0.09  | 1.716 | 53.6  | 50 | 1.83     | 0.44  | 1.489 | 70.2  |
| 23 | 3.80    | 0.19  | 1.727 | 29.0  | 51 | -3.86    | 0.00  |       |       |
| 24 | -27.68  | *** 3 |       |       | 52 | 2.04     | 0.29  | 1.489 | 70.2  |
| 25 | 20.68   | 0.24  | 1.503 | 56.2  | 53 | 39.87    | 0.78  |       |       |
| 26 | -3.89   | 0.00  |       |       | 54 | $\infty$ | 3.30  | 1.518 | 64.0  |
| 27 | 8.66    | 0.26  | 1.503 | 56.2  | 55 | $\infty$ |       |       |       |
| 28 | -5.23   | 0.12  |       |       |    |          |       |       |       |

(1) E. F. L = 1.0

\*\*\* 1 = 0.013; \*\*\* 2 = 4.456; \*\*\* 3 = 1.418; \*\*\* 4 = 0.068; \*\*\* 5 = 0.123; \*\*\* 6 = 1.439

(2) E. F. L = 14.5

\*\*\* 1 = 5.174; \*\*\* 2 = 0.675; \*\*\* 3 = 0.038; \*\*\* 4 = 0.068; \*\*\* 5 = 0.123; \*\*\* 6 = 1.439

(3) E. F. L = 29.6

\*\*\* 1 = 5.174; \*\*\* 2 = 0.675; \*\*\* 3 = 0.038; \*\*\* 4 = 0.574; \*\*\* 5 = 1.042; \*\*\* 6 = 0.014

编号: 04-03-038

# 大倍率变焦距镜头

E. F. L = 13~286      B. F. L =      FNo. = 3.5      F. A. =  $\pm 30.8^\circ \sim \pm 1.5^\circ$

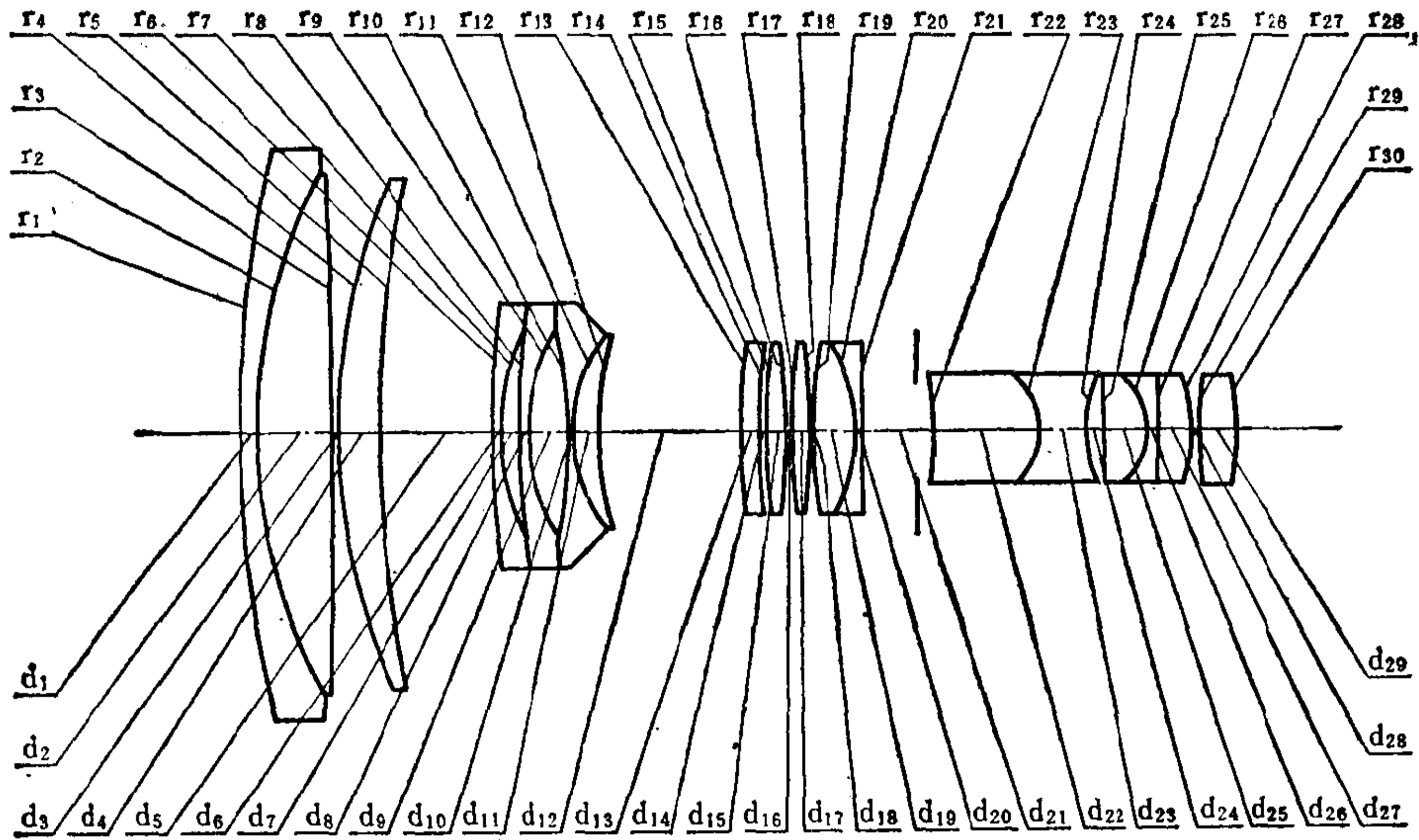

| 序号 | r         | d     | n       | v    | 序号 | r         | d     | n       | v    |
|----|-----------|-------|---------|------|----|-----------|-------|---------|------|
| 1  | 210.4470  | 2.20  | 1.78472 | 25.7 | 16 | -144.0000 | 0.10  |         |      |
| 2  | 90.0000   | 12.00 | 1.61405 | 55.1 | 17 | 86.8940   | 3.00  | 1.62606 | 39.1 |
| 3  | -937.4600 | 0.10  |         |      | 18 | -144.0000 | 0.10  |         |      |
| 4  | 98.5820   | 7.30  | 1.51835 | 60.3 | 19 | 69.1000   | 7.50  | 1.73601 | 51.0 |
| 5  | 425.3202  | *** 1 |         |      | 20 | -26.1670  | 1.01  | 1.78472 | 25.7 |
| 6  | 246.0000  | 0.85  | 1.64006 | 60.0 | 21 | 1008.7200 | *** 3 |         |      |
| 7  | 34.4000   | 3.40  |         |      | 22 | -40.2700  | 17.00 | 1.72342 | 38.0 |
| 8  | 210.2000  | 0.85  | 1.64006 | 60.0 | 23 | -11.8000  | 7.50  | 1.62045 | 38.0 |
| 9  | 28.9270   | 6.50  |         |      | 24 | 19.2000   | 2.40  |         |      |
| 10 | -82.4800  | 0.75  | 1.51728 | 69.6 | 25 | $\infty$  | 7.45  | 1.44628 | 67.2 |
| 11 | 25.0000   | 4.35  | 1.78472 | 25.7 | 26 | -9.8640   | 1.45  | 1.57250 | 57.5 |
| 12 | 65.1988   | *** 2 |         |      | 27 | $\infty$  | 5.80  | 1.46450 | 65.8 |
| 13 | 346.6000  | 3.00  | 1.61840 | 44.2 | 28 | -19.7040  | 0.05  |         |      |
| 14 | 557.6000  | 0.10  |         |      | 29 | 59.9000   | 5.80  | 1.51118 | 50.9 |
| 15 | 86.8940   | 3.00  | 1.62606 | 39.1 | 30 | -77.4000  |       |         |      |

(1) E. F. L = 13

\*\*\* 1 = 0.4100; \*\*\* 2 = 102.1968; \*\*\* 3 = 3.6837

(2) E. F. L = 286

\*\*\* 1 = 99.3295; \*\*\* 2 = 3.2768; \*\*\* 3 = 26.6837

编号: 04-03-039

## 用于中心快门照相机的变焦距镜头

E. F. L = 50.00 ~ 121.00      B. F. L = 39.17      FNo. =      F. A. =

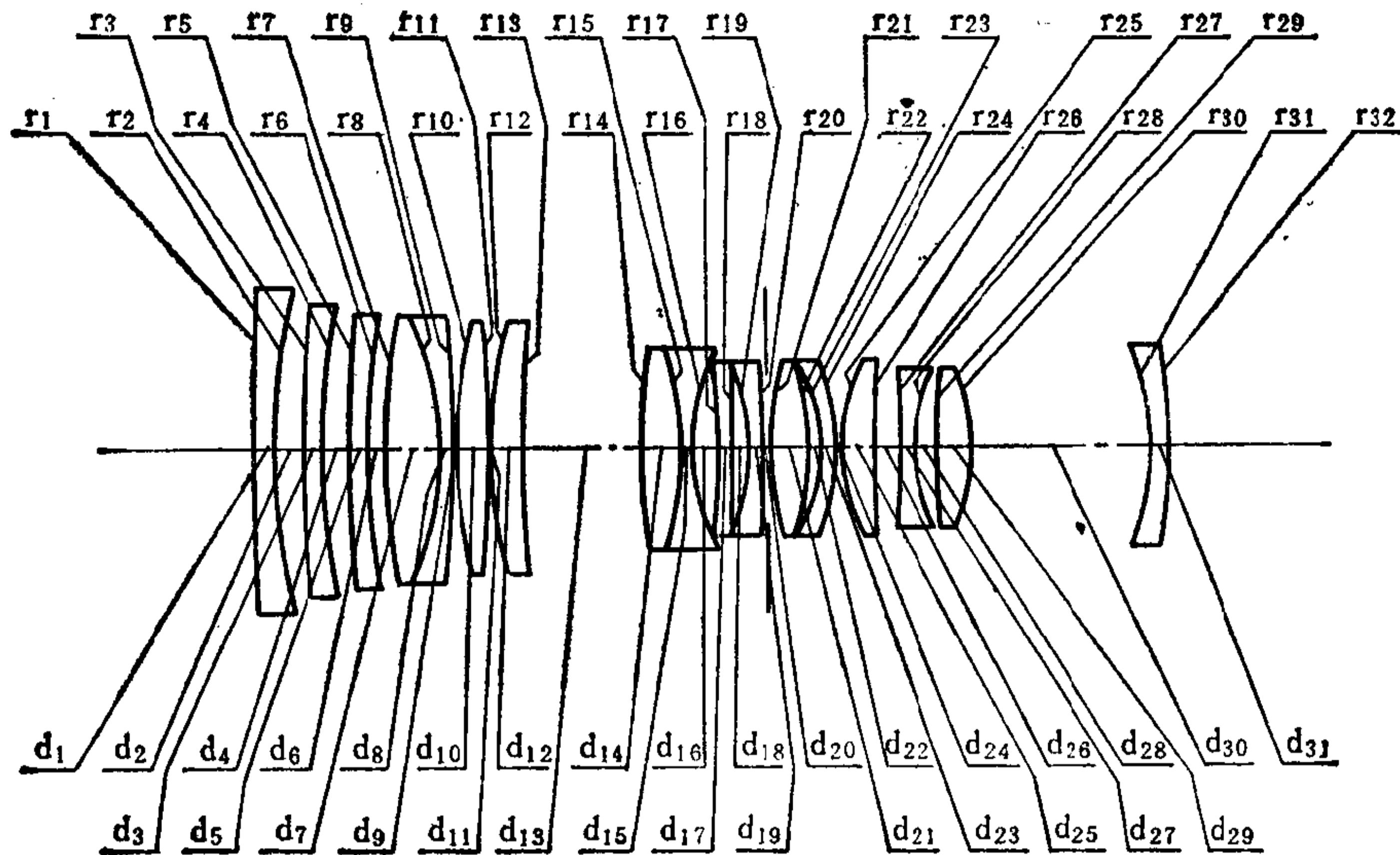

| 序号 | r       | d     | n <sub>D</sub> | v <sub>D</sub> | 序号 | r       | d     | n <sub>D</sub> | v <sub>D</sub> |
|----|---------|-------|----------------|----------------|----|---------|-------|----------------|----------------|
| 1  | 883.57  | 2.50  | 1.744          | 44.90          | 17 | -97.46  | 1.60  | 1.8374         | 43.47          |
| 2  | 79.58   | 3.50  |                |                | 18 | -763.85 | 1.90  |                |                |
| 3  | 250.10  | 2.50  | 1.744          | 44.90          | 19 | -32.28  | 1.74  | 1.8374         | 43.47          |
| 4  | 80.70   | 3.50  |                |                | 20 | 1323.99 | *** 3 |                |                |
| 5  | 270.88  | 2.50  | 1.744          | 44.90          | 21 | 40.86   | 5.00  | 1.5168         | 64.19          |
| 6  | 96.67   | *** 1 |                |                | 22 | -35.35  | 1.40  |                |                |
| 7  | 93.11   | 7.00  | 1.720          | 50.31          | 23 | -20.77  | 2.00  | 1.7495         | 34.99          |
| 8  | -40.45  | 1.50  | 1.7215         | 29.28          | 24 | -30.16  | 0.50  |                |                |
| 9  | -160.61 | 0.25  |                |                | 25 | 23.57   | 4.50  | 1.6204         | 60.29          |
| 10 | 63.85   | 4.00  | 1.691          | 54.79          | 26 | 182.45  | 3.00  |                |                |
| 11 | -240.37 | 0.25  |                |                | 27 | -233.63 | 2.00  | 1.720          | 50.31          |
| 12 | 56.17   | 4.16  | 1.691          | 54.79          | 28 | 20.35   | 3.00  |                |                |
| 13 | 310.44  | *** 2 |                |                | 29 | 108.73  | 4.50  | 1.6204         | 60.29          |
| 14 | 84.77   | 4.50  | 1.7215         | 29.28          | 30 | -25.16  | 22.30 |                |                |
| 15 | -43.06  | 1.50  | 1.720          | 50.31          | 31 | -39.23  | 2.00  | 1.7215         | 29.28          |
| 16 | 26.21   | 3.50  |                |                | 32 | -96.03  |       |                |                |

(1) E. F. L = 50.00

\*\*\* 1 = 1.93; \*\*\* 2 = 15.15; \*\*\* 3 = 1.00

(2) E. F. L = 121.00

\*\*\* 1 = 16.33; \*\*\* 2 = 0.75; \*\*\* 3 = 15.40



编号: 04-03-040

# 小型的变焦距镜头

E. F. L = 50.06 ~ 121.63      B. F. L = 52.0      FNo. =      F. A. =

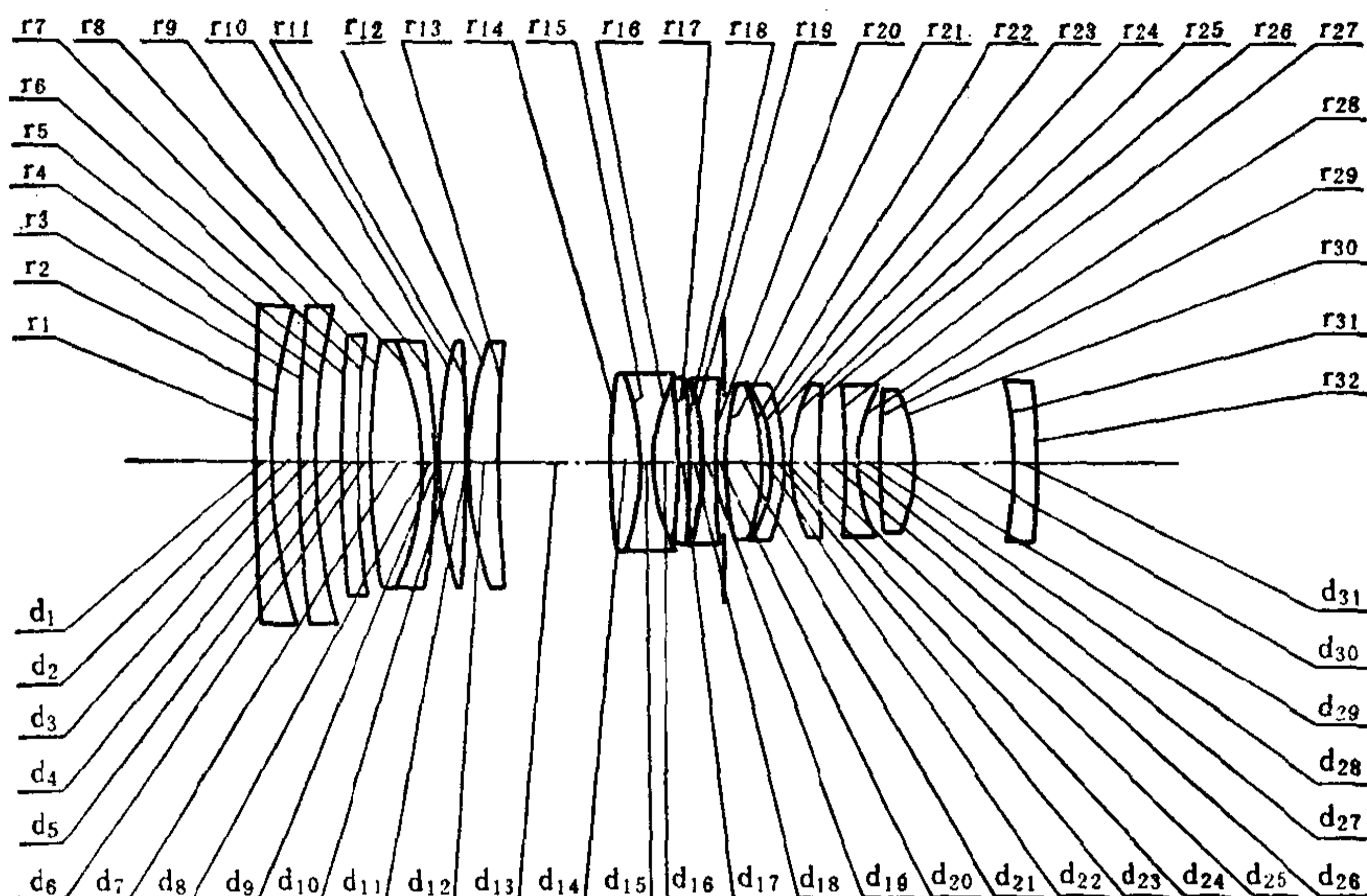

| 序号 | r       | d     | n <sub>D</sub> | v <sub>D</sub> | 序号 | r        | d     | n <sub>D</sub> | v <sub>D</sub> |
|----|---------|-------|----------------|----------------|----|----------|-------|----------------|----------------|
| 1  | 716.00  | 2.50  | 1.744          | 44.90          | 17 | -96.74   | 1.60  | 1.8028         | 46.75          |
| 2  | 78.13   | 3.50  |                |                | 18 | -1137.40 | 1.90  |                |                |
| 3  | 379.87  | 2.50  | 1.744          | 44.90          | 19 | -32.22   | 1.60  | 1.8028         | 46.75          |
| 4  | 89.00   | 3.50  |                |                | 20 | 552.18   | *** 3 |                |                |
| 5  | 464.40  | 2.50  | 1.744          | 44.90          | 21 | 40.94    | 5.00  | 1.5168         | 64.19          |
| 6  | 118.02  | *** 1 |                |                | 22 | -35.64   | 1.40  |                |                |
| 7  | 103.38  | 7.00  | 1.720          | 50.31          | 23 | -20.63   | 2.00  | 1.7215         | 29.28          |
| 8  | -41.56  | 1.50  | 1.7215         | 29.28          | 24 | -30.30   | 0.50  |                |                |
| 9  | -140.22 | 0.25  |                |                | 25 | 24.07    | 4.50  | 1.6204         | 60.29          |
| 10 | 63.58   | 4.00  | 1.691          | 54.79          | 26 | 210.40   | 3.10  |                |                |
| 11 | -258.75 | 0.25  |                |                | 27 | -171.72  | 2.00  | 1.7200         | 50.31          |
| 12 | 54.03   | 4.20  | 1.691          | 54.79          | 28 | 20.98    | 3.00  |                |                |
| 13 | 270.16  | *** 2 |                |                | 29 | 111.76   | 4.50  | 1.6204         | 60.29          |
| 14 | 86.41   | 4.50  | 1.7215         | 29.28          | 30 | -25.00   | 13.50 |                |                |
| 15 | -35.64  | 1.50  | 1.7200         | 50.31          | 31 | -64.44   | 3.60  | 1.7215         | 29.28          |
| 16 | 26.30   | 3.40  |                |                | 32 | -210.40  |       |                |                |

(1) E. F. L = 50.06

\*\*\* 1 = 1.73; \*\*\* 2 = 15.29; \*\*\* 3 = 1.00

(2) E. F. L = 121.63

\*\*\* 1 = 16.13; \*\*\* 2 = 0.89; \*\*\* 3 = 15.40

编号: 04-03-041

## 具有两个光栏的变焦距镜头

E. F. L = 6.675 ~ 38.477

B. F. L =

FNo. = 1.85

F. A. =

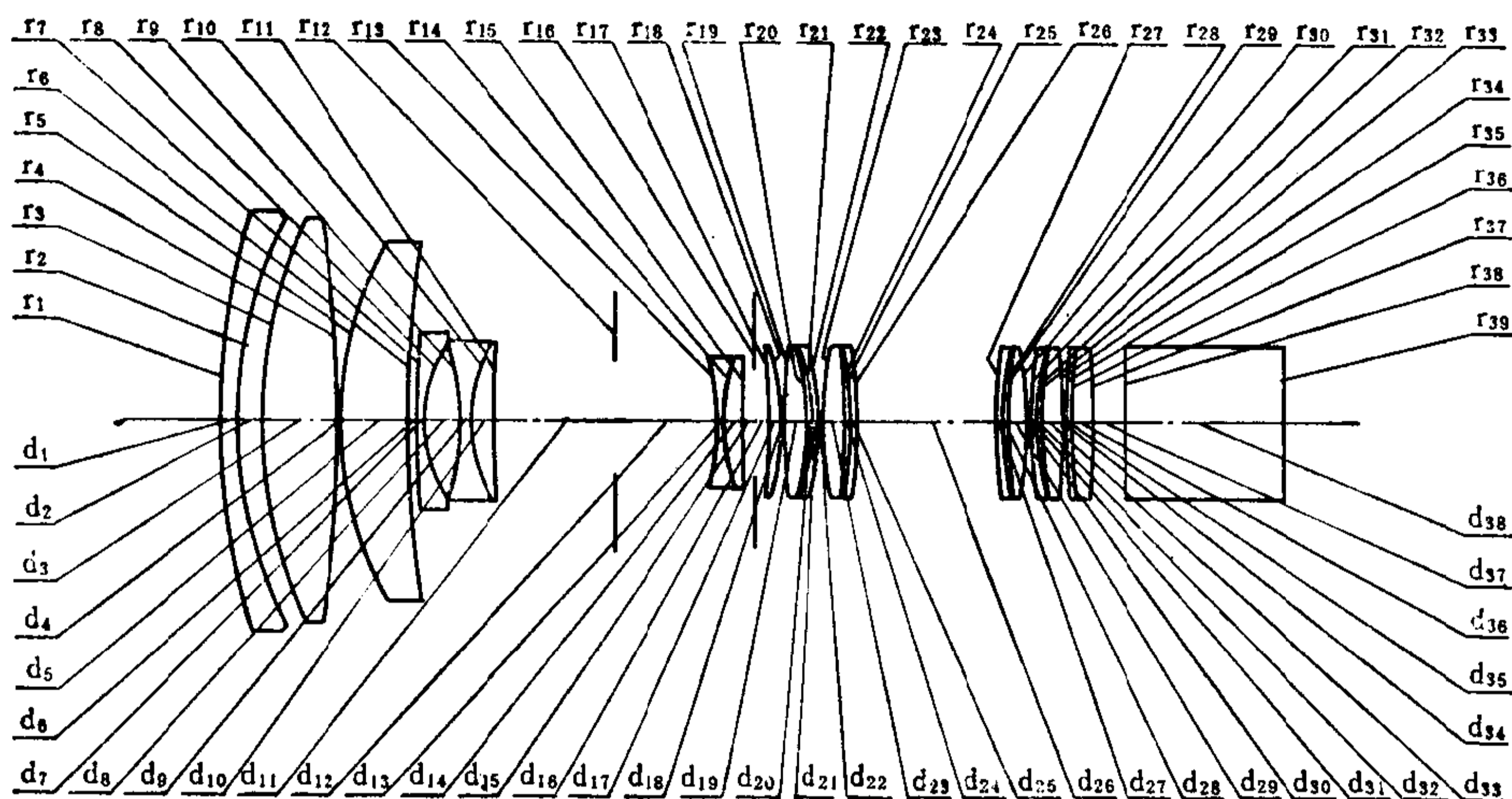

| 序号 | r          | d       | n       | v    | 序号 | r         | d        | n       | v    |
|----|------------|---------|---------|------|----|-----------|----------|---------|------|
| 1  | 59.75000   | 1.30000 | 1.92286 | 21.3 | 21 | -15.25000 | 0.50000  | 1.80518 | 25.4 |
| 2  | 35.60000   | 1.95000 |         |      | 22 | -19.50000 | 0.10000  |         |      |
| 3  | 38.17000   | 8.50000 | 1.61800 | 63.4 | 23 | 32.06353  | 1.80000  | 1.62041 | 60.3 |
| 4  | -230.97000 | 0.13000 |         |      | 24 | -67.73000 | 0.50000  |         |      |
| 5  | 28.73552   | 5.65000 | 1.61800 | 63.4 | 25 | -26.55000 | 0.50000  | 1.80518 | 25.4 |
| 6  | 124.93000  | *** 1   |         |      | 26 | -42.23000 | 13.42244 |         |      |
| 7  | 292.74000  | 0.50000 | 1.88300 | 41.0 | 27 | 56.36000  | 0.50000  | 1.80518 | 25.4 |
| 8  | 10.73000   | 2.90000 |         |      | 28 | 27.56000  | 0.60000  |         |      |
| 9  | -19.93751  | 0.60000 | 1.78650 | 50.2 | 29 | 174.60000 | 1.50000  | 1.71300 | 54.0 |
| 10 | 11.90000   | 2.10000 | 1.92286 | 21.3 | 30 | -34.81000 | 0.13000  |         |      |
| 11 | 246.32000  | *** 2   |         |      | 31 | 33.98000  | 0.50000  | 1.80518 | 25.4 |
| 12 | ∞ ①        | *** 3   |         |      | 32 | 21.07000  | 0.23000  |         |      |
| 13 | -20.98952  | 0.50000 | 1.80610 | 40.8 | 33 | 28.06475  | 1.70000  | 1.71300 | 54.0 |
| 14 | 16.41000   | 1.60000 | 1.80518 | 25.4 | 34 | -86.88000 | 0.13000  |         |      |
| 15 | ∞          | *** 4   |         |      | 35 | 115.52000 | 0.50000  | 1.80518 | 25.4 |
| 16 | ∞ ①        | 1.00000 |         |      | 36 | 38.69000  | 1.70000  | 1.71300 | 54.0 |
| 17 | -57.13000  | 1.30000 | 1.62041 | 60.3 | 37 | -83.67000 | 2.60000  |         |      |
| 18 | -20.12000  | 0.10000 |         |      | 38 | ∞         | 13.00000 | 1.51633 | 64.1 |
| 19 | 134.00000  | 1.70000 | 1.62041 | 60.3 | 39 | ∞         |          |         |      |
| 20 | -25.02000  | 0.53000 |         |      |    |           |          |         |      |

① 系双光栏，在计算时分别按平面处理。

(1) E. F. L = 6.675

\*\*\* 1 = 0.886156; \*\*\* 2 = 9.771670; \*\*\* 3 = 12.349600; \*\*\* 4 = 0.759890

(2) E. F. L = 18.126

\*\*\* 1 = 13.915757; \*\*\* 2 = 0.266933; \*\*\* 3 = 6.297661; \*\*\* 4 = 3.287400

(3) E. F. L = 38.477

\*\*\* 1 = 19.934757; \*\*\* 2 = 0.397002; \*\*\* 3 = 0.847105; \*\*\* 4 = 2.588871

编号: 04-03-042

# 超远摄型变焦距镜头

E. F. L = 360 ~ 1200

B. F. L =

FNo. = 11

F. A. =

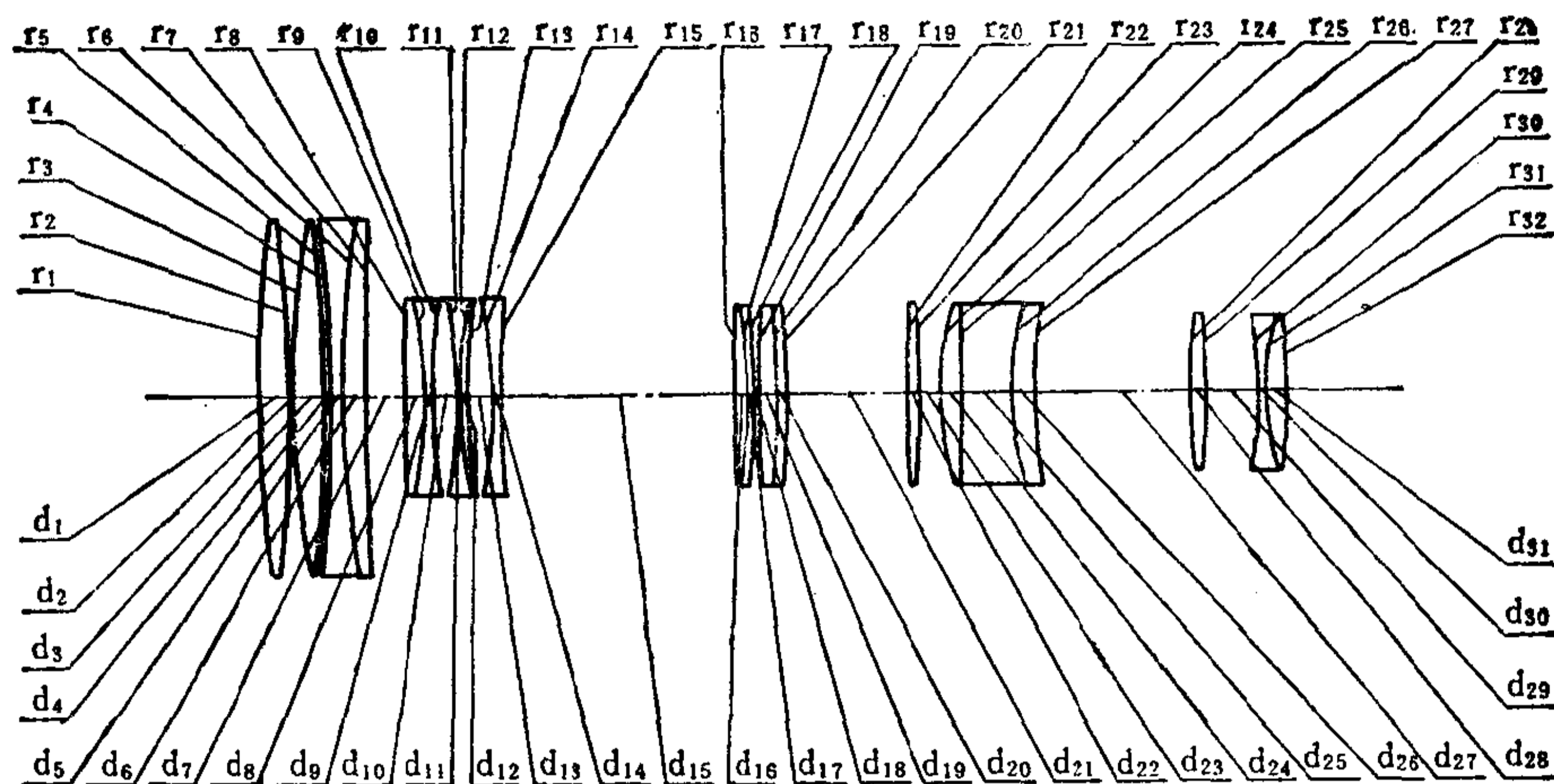

| 序号 | r         | d     | n       | v    | 序号 | r         | d     | n       | v    |
|----|-----------|-------|---------|------|----|-----------|-------|---------|------|
| 1  | 441.500   | 8.0   | 1.48606 | 81.5 | 17 | -134.200  | 2.6   | 1.61293 | 36.9 |
| 2  | -580.000  | 0.2   |         |      | 18 | -203.700  | 0.2   |         |      |
| 3  | 274.200   | 9.5   | 1.48606 | 81.5 | 19 | 398.100   | 4.7   | 1.48606 | 81.5 |
| 4  | -638.100  | 1.0   |         |      | 20 | -143.200  | 2.6   | 1.75520 | 27.5 |
| 5  | -638.100  | 4.0   | 1.744   | 44.9 | 21 | -246.400  | *** 3 |         |      |
| 6  | 298.200   | 6.0   | 1.58913 | 61.2 | 22 | 344.600   | 4.0   | 1.51454 | 54.6 |
| 7  | 1281.500  | *** 1 |         |      | 23 | -577.700  | 6.2   |         |      |
| 8  | 8939.700  | 4.7   | 1.75520 | 27.5 | 24 | 85.800    | 6.0   | 1.48606 | 81.5 |
| 9  | -126.600  | 2.6   | 1.58913 | 61.2 | 25 | -1535.000 | 13.5  | 1.744   | 44.9 |
| 10 | 172.900   | 6.0   |         |      | 26 | 80.000    | 6.3   | 1.6398  | 45.0 |
| 11 | -166.700  | 1.3   | 1.48606 | 81.5 | 27 | 136.359   | 139.4 |         |      |
| 12 | 118.300   | 3.0   | 1.58875 | 51.2 | 28 | 385.100   | 2.7   | 1.50137 | 56.5 |
| 13 | 238.700   | 6.0   |         |      | 29 | -385.100  | 15.2  |         |      |
| 14 | -149.800  | 2.6   | 1.5168  | 64.2 | 30 | -124.900  | 2.8   | 1.74443 | 49.4 |
| 15 | 444.700   | *** 2 |         |      | 31 | 87.500    | 4.4   | 1.60342 | 38.0 |
| 16 | -3106.900 | 3.5   | 1.62041 | 60.3 | 32 | -200.400  |       |         |      |

(1) E. F. L = 360

\*\*\* 1 = 11.258; \*\*\* 2 = 64.853; \*\*\* 3 = 143.138

(2) E. F. L = 1200

\*\*\* 1 = 211.258; \*\*\* 2 = 4.248; \*\*\* 3 = 3.744

编号: 04-03-043

# 大孔径广角变焦距镜头

E. F. L = 39.50 ~ 375.96

B. F. L =

FNo. =

F. A. =

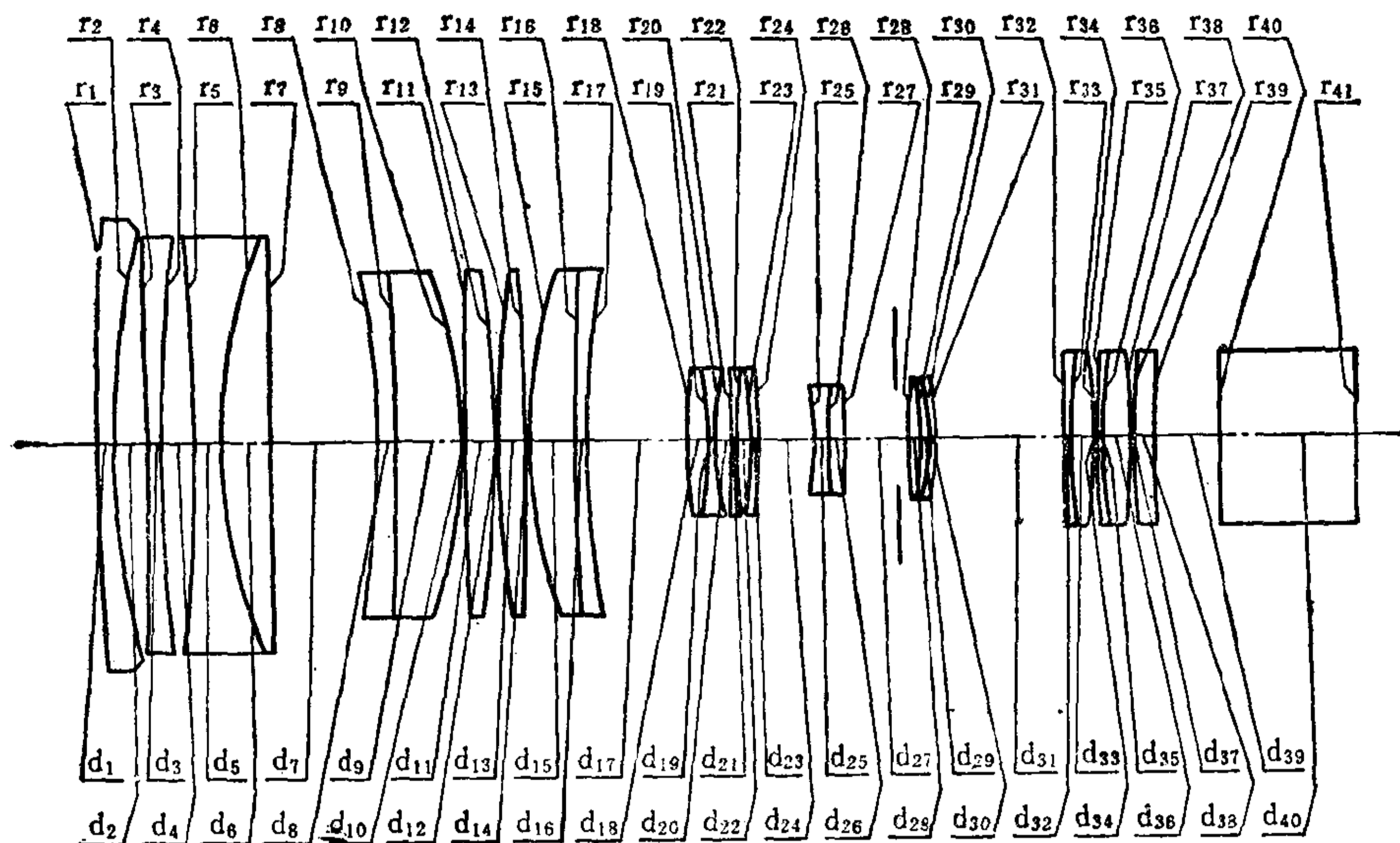

| 序号 | r           | d         | n <sub>d</sub> | v    | 序号 | r          | d          | n <sub>d</sub> | v    |
|----|-------------|-----------|----------------|------|----|------------|------------|----------------|------|
| 1  | 947.50268   | 5.000000  | 1.713          | 53.9 | 22 | 262.80000  | 4.40500    |                |      |
| 2  | 305.84000   | 11.264000 |                |      | 23 | -134.77000 | 2.000000   | 1.883          | 41.0 |
| 3  | -1975.00000 | 5.000000  | 1.713          | 53.9 | 24 | -369.15045 | *** 2      |                |      |
| 4  | 610.00000   | 8.645000  |                |      | 25 | -103.94000 | 5.000000   | 1.757          | 47.7 |
| 5  | -652.48000  | 10.000000 | 1.67003        | 47.2 | 26 | 255.71000  | 5.000000   | 1.78472        | 25.7 |
| 6  | 171.74000   | 16.000000 | 1.72825        | 28.3 | 27 | -413.00332 | *** 3      |                |      |
| 7  | ∞           | 62.772725 |                |      | 28 | 213.51000  | 6.500000   | 1.48749        | 70.0 |
| 8  | -308.57000  | 6.000000  | 1.7552         | 27.5 | 29 | -106.76000 | 2.500000   |                |      |
| 9  | -1905.80000 | 21.000000 | 1.48749        | 70.0 | 30 | -63.19000  | 2.000000   | 1.80518        | 25.5 |
| 10 | -162.48000  | 0.100000  |                |      | 31 | -79.19153  | 176.293160 |                |      |
| 11 | 1229.45000  | 10.000000 | 1.48749        | 70.0 | 32 | ∞          | 2.000000   | 1.66446        | 35.9 |
| 12 | -379.98000  | 0.100000  |                |      | 33 | 243.56000  | 8.500000   | 1.4645         | 65.7 |
| 13 | 340.42000   | 10.100000 | 1.48749        | 70.0 | 34 | -194.83000 | 0.100000   |                |      |
| 14 | -1975.00000 | 0.100000  |                |      | 35 | 495.75000  | 2.000000   | 1.66446        | 35.9 |
| 15 | 169.98000   | 15.000000 | 1.48749        | 70.0 | 36 | 163.10000  | 8.500000   | 1.4645         | 65.7 |
| 16 | 2633.33000  | 4.000000  | 1.7552         | 27.5 | 37 | -321.82000 | 0.100000   |                |      |
| 17 | 405.85090   | *** 1     |                |      | 38 | 409.09000  | 5.700000   | 1.62041        | 60.3 |
| 18 | 372.49000   | 7.000000  | 1.92286        | 20.9 | 39 | 1039.37230 | 50.000000  |                |      |
| 19 | -118.53000  | 2.000000  | 1.841          | 43.2 | 40 | ∞          | 82.200000  | 1.51633        | 64.1 |
| 20 | 118.53000   | 4.208000  |                |      | 41 | ∞          |            |                |      |
| 21 | -618.65000  | 2.000000  | 1.883          | 41.0 |    |            |            |                |      |

(1) E. F. L = 39.50

\*\*\* 1 = 3.7540141; \*\*\* 2 = 217.2927000; \*\*\* 3 = 6.8377210

(2) E. F. L = 164.70

\*\*\* 1 = 164.3095800; \*\*\* 2 = 31.4230730; \*\*\* 3 = 32.1517840

(3) E. F. L = 375.96

\*\*\* 1 = 216.3512000; \*\*\* 2 = 4.6955089; \*\*\* 3 = 6.8377210



编号: 04-03-044

# 大孔径变焦距物镜

E.F.L = 1.0 ~ 13.3

B.F.L = 2.37

FNo. = 1.8

F.A. =

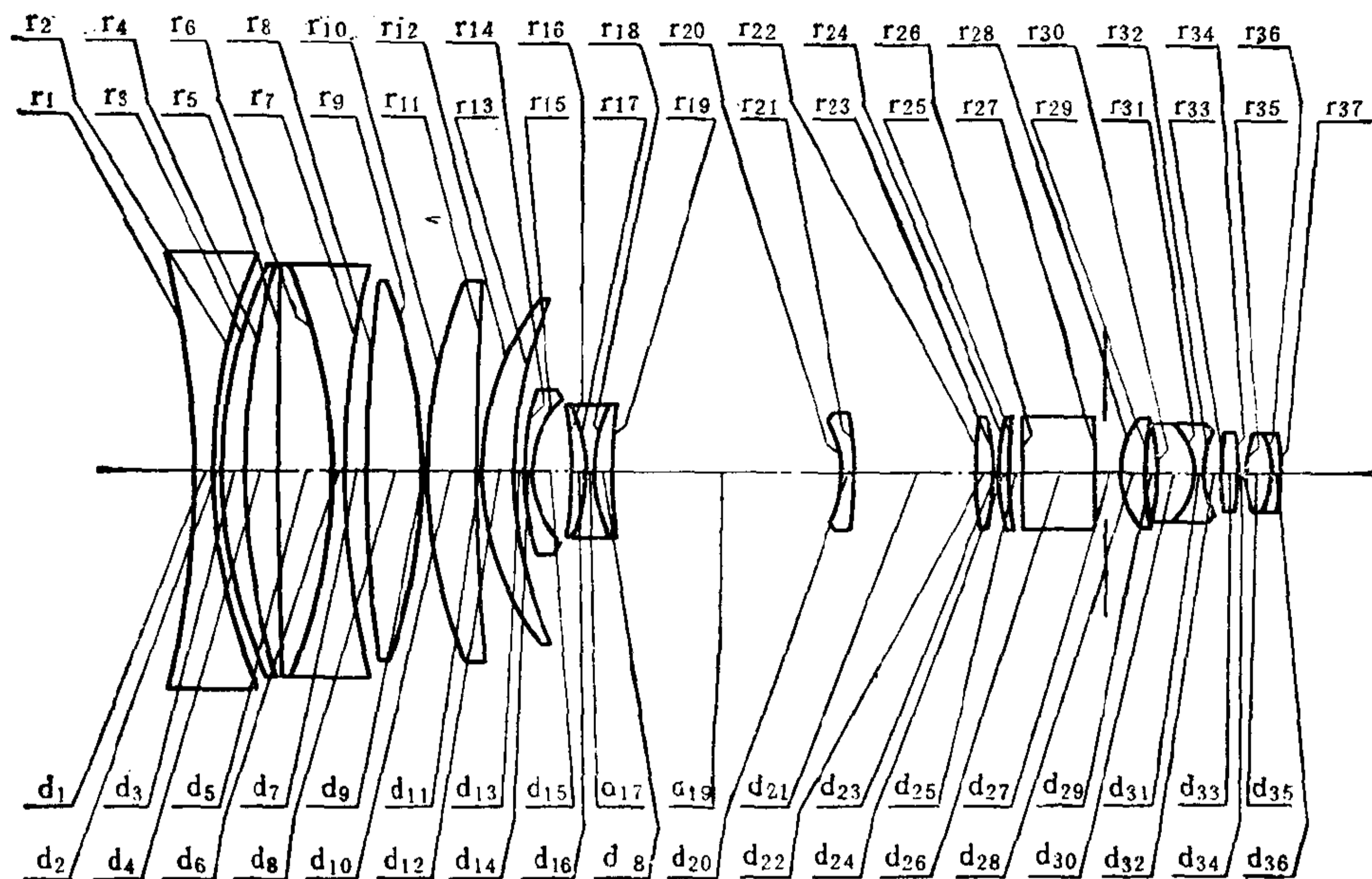

| 序号 | r       | d     | nd      | v    | 序号 | r       | d     | nd      | v    |
|----|---------|-------|---------|------|----|---------|-------|---------|------|
| 1  | -19.190 | 0.411 | 1.62041 | 60.3 | 20 | -3.048  | 0.274 | 1.62280 | 56.9 |
| 2  | 12.233  | 0.205 |         |      | 21 | -12.173 | *** 3 |         |      |
| 3  | 11.041  | 0.616 | 1.69895 | 30.1 | 22 | 13.014  | 0.370 | 1.52542 | 64.7 |
| 4  | 17.302  | 0.692 |         |      | 23 | -6.086  | 0.010 |         |      |
| 5  | 94.523  | 1.206 | 1.71300 | 53.8 | 24 | 4.803   | 0.292 | 1.52542 | 64.7 |
| 6  | -12.003 | 0.360 | 1.76180 | 26.9 | 25 | 18.820  | 0.274 |         |      |
| 7  | 20.559  | 0.479 |         |      | 26 | ∞       | 1.644 | 1.51680 | 64.2 |
| 8  | 34.478  | 1.438 | 1.64050 | 60.1 | 27 | ∞       | 0.616 |         |      |
| 9  | -10.863 | 0.010 |         |      | 28 | 2.073   | 0.558 | 1.48749 | 70.4 |
| 10 | 11.521  | 1.096 | 1.64050 | 60.1 | 29 | 6.856   | 0.219 |         |      |
| 11 | 94.527  | 0.010 |         |      | 30 | -5.421  | 0.884 | 1.76180 | 27.0 |
| 12 | 6.378   | 0.810 | 1.64050 | 60.1 | 31 | -1.658  | 0.190 | 1.67270 | 32.2 |
| 13 | 10.589  | *** 1 |         |      | 32 | 2.260   | 0.419 |         |      |
| 14 | 6.474   | 0.195 | 1.69100 | 54.7 | 33 | 4.888   | 0.437 | 1.48749 | 70.4 |
| 15 | 2.292   | 0.918 |         |      | 34 | -5.536  | 0.051 |         |      |
| 16 | -7.537  | 0.329 | 1.80518 | 25.4 | 35 | 2.364   | 0.575 | 1.50137 | 56.4 |
| 17 | -3.697  | 0.195 | 1.71300 | 53.8 | 36 | -2.170  | 0.205 | 1.80518 | 25.4 |
| 18 | 3.415   | 0.438 | 1.80518 | 25.4 | 37 | -5.525  |       |         |      |
| 19 | 11.113  | *** 2 |         |      |    |         |       |         |      |

- (1) E.F.L = 1.0  
\*\*\* 1 = 0.137; \*\*\* 2 = 5.497; \*\*\* 3 = 2.837
- (2) E.F.L = 2.1  
\*\*\* 1 = 3.013; \*\*\* 2 = 2.262; \*\*\* 3 = 3.196
- (3) E.F.L = 4.3  
\*\*\* 1 = 4.907; \*\*\* 2 = 0.598; \*\*\* 3 = 2.966
- (4) E.F.L = 7.6  
\*\*\* 1 = 5.912; \*\*\* 2 = 0.597; \*\*\* 3 = 1.962
- (5) E.F.L = 10.3  
\*\*\* 1 = 6.269; \*\*\* 2 = 1.114; \*\*\* 3 = 1.088
- (6) E.F.L = 13.3  
\*\*\* 1 = 6.475; \*\*\* 2 = 1.781; \*\*\* 3 = 0.215

编号: 04-03-045●

# 大倍率变焦距镜头

E.F.L=6.0~128.5    B.F.L=    FNo. =1.8    F.A. = ± 30.8° ~ ± 1.5°

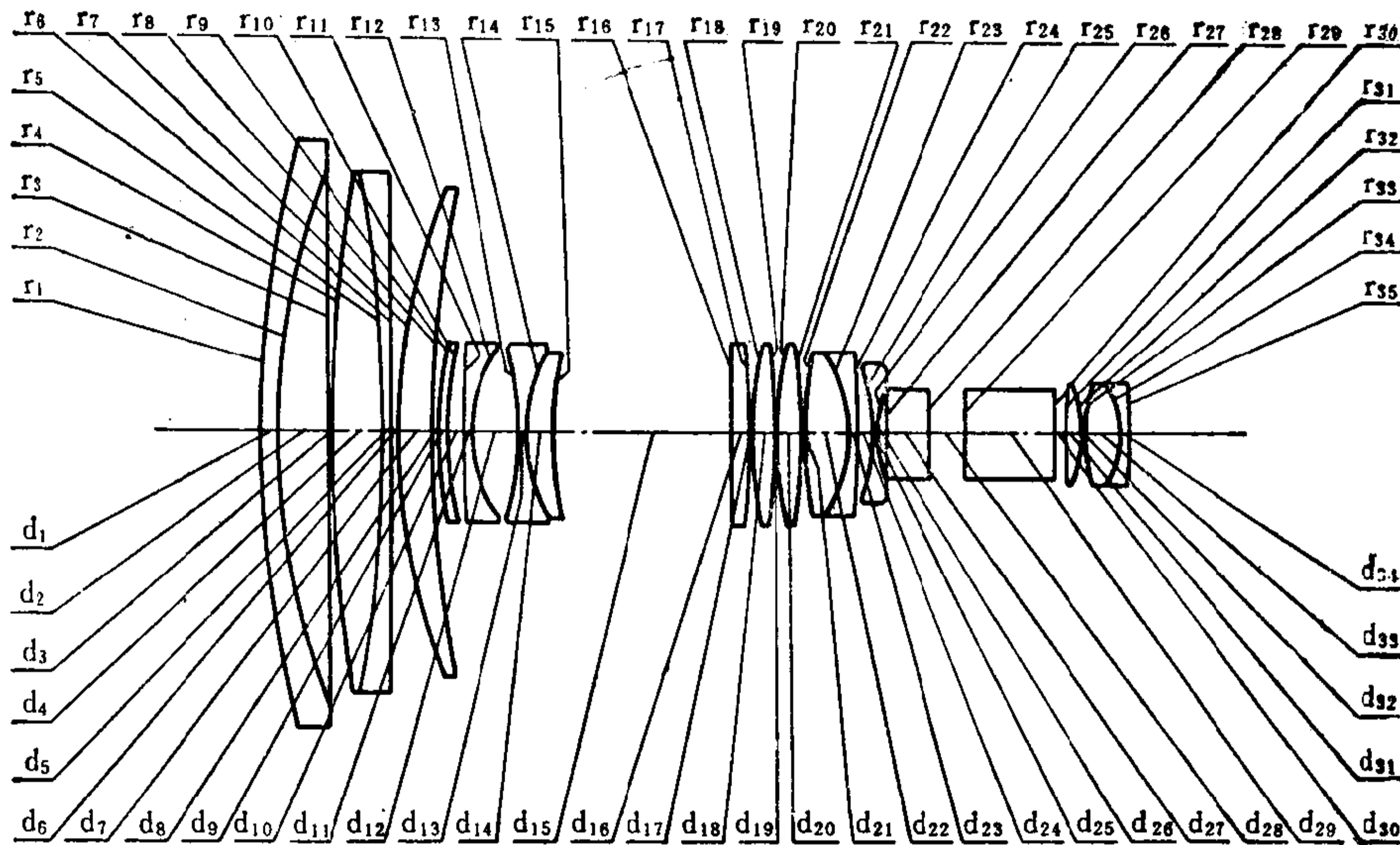

| 序号 | r         | d     | n       | va   | 序号 | r        | d     | n       | va   |
|----|-----------|-------|---------|------|----|----------|-------|---------|------|
| 1  | 198.000   | 1.90  | 1.740   | 28.2 | 19 | -154.320 | 0.10  |         |      |
| 2  | 115.617   | 9.00  | 1.51728 | 69.6 | 20 | 73.650   | 3.50  | 1.62041 | 60.3 |
| 3  | 2025.800  | 0.10  |         |      | 21 | -141.330 | 0.10  |         |      |
| 4  | 250.898   | 7.70  | 1.51728 | 69.6 | 22 | 62.200   | 7.30  | 1.67790 | 55.5 |
| 5  | -250.898  | 1.90  | 1.740   | 28.2 | 23 | -23.854  | 1.00  | 1.740   | 28.2 |
| 6  | -582.377  | 0.10  |         |      | 24 | -655.518 | *** 3 |         |      |
| 7  | 93.500    | 6.10  | 1.5168  | 64.2 | 25 | -33.884  | 0.70  | 1.5168  | 64.2 |
| 8  | 260.459   | *** 1 |         |      | 26 | 23.900   | 1.20  |         |      |
| 9  | 85.740    | 1.10  | 1.744   | 44.9 | 27 | ∞        | 7.00  | 1.57501 | 41.3 |
| 10 | 45.562    | 3.10  |         |      | 28 | ∞        | 5.80  |         |      |
| 11 | 790.330   | 1.10  | 1.6968  | 55.6 | 29 | ∞        | 13.90 | 1.57501 | 41.3 |
| 12 | 21.493    | 7.70  |         |      | 30 | ∞        | 1.30  |         |      |
| 13 | -53.850   | 0.85  | 1.5168  | 64.2 | 31 | 99.500   | 2.90  | 1.53172 | 48.9 |
| 14 | 23.400    | 5.10  | 1.80518 | 25.5 | 32 | -21.336  | 0.20  |         |      |
| 15 | 71.697    | *** 2 |         |      | 33 | 26.710   | 5.30  | 1.60717 | 40.2 |
| 16 | -1229.864 | 3.10  | 1.62280 | 56.9 | 34 | -16.559  | 1.20  | 1.86074 | 23.1 |
| 17 | -167.880  | 0.10  |         |      | 35 | -175.330 |       |         |      |
| 18 | 70.667    | 3.50  | 1.62041 | 60.3 |    |          |       |         |      |

(1) E.F.L=6.0

\*\*\* 1 = 0.46°; \*\*\* 2 = 102.888; \*\*\* 3 = 2.148

(2) E.F.L=128.5

\*\*\* 1 = 80.633; \*\*\* 2 = 2.731; \*\*\* 3 = 22.135

● 后固定组仅供参考。

编号: 04-03-046●

## 五组变焦距镜头

E.F.L=9.5~50.0 B.F.L= FNo.=1.8 F.A.=±20.75°~±4.14°

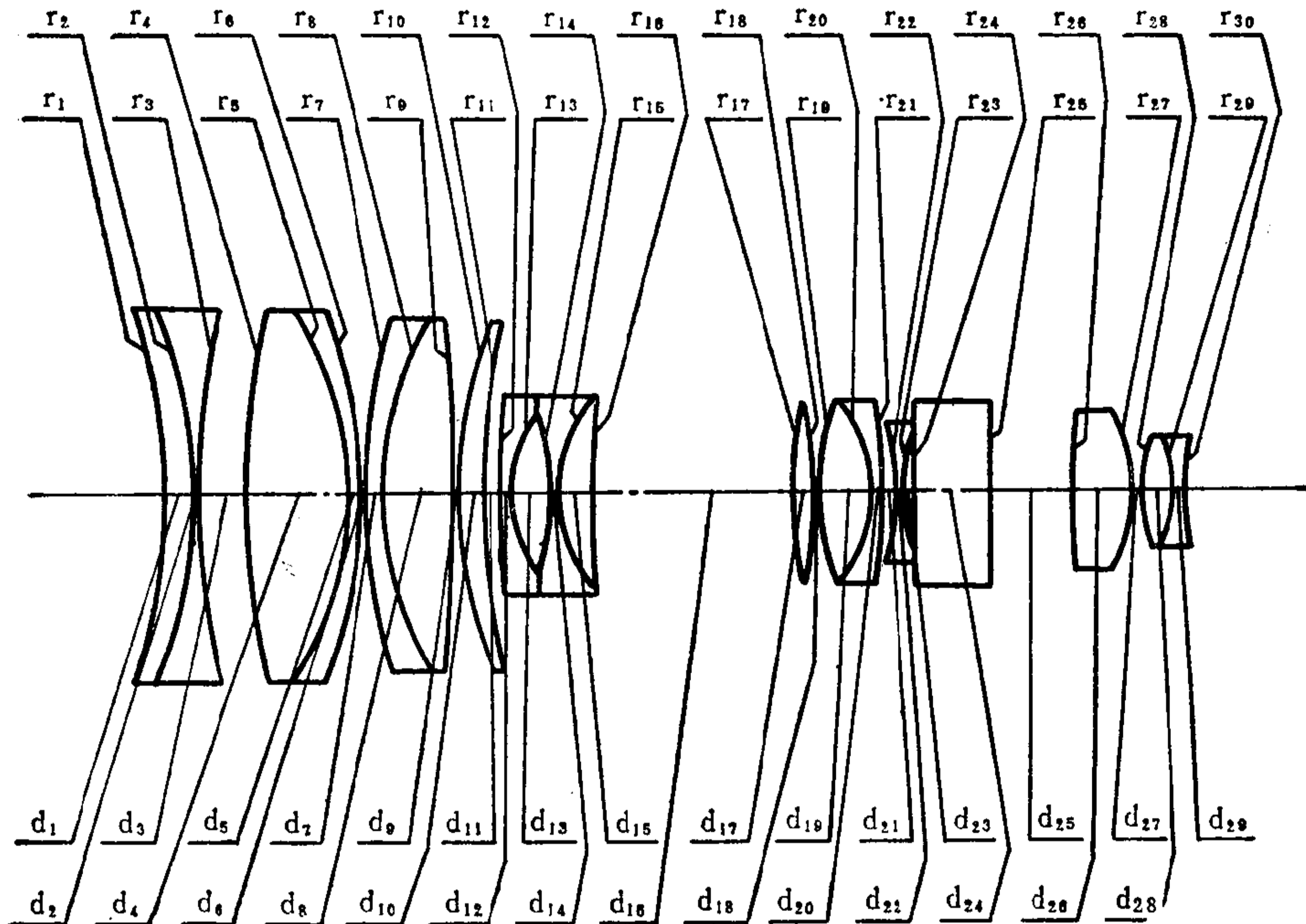

| 序号 | r        | d     | n <sub>D</sub> | v | 序号 | r       | d     | n <sub>D</sub> | v |
|----|----------|-------|----------------|---|----|---------|-------|----------------|---|
| 1  | -79.100  | 3.9   | 1.74077        |   | 16 | 130.440 | *** 2 |                |   |
| 2  | -56.000  | 0.8   | 1.62041        |   | 17 | 60.000  | 2.7   |                |   |
| 3  | 110.610  | 6.3   |                |   | 18 | -51.315 | 0.1   |                |   |
| 4  | 131.135  | 11.2  | 1.5168         |   | 19 | 33.640  | 6.3   |                |   |
| 5  | -40.000  | 1.6   | 1.69895        |   | 20 | -16.780 | 0.8   |                |   |
| 6  | -59.050  | 0.2   |                |   | 21 | -95.933 | *** 3 |                |   |
| 7  | 85.400   | 1.4   | 1.76182        |   | 22 | -28.800 | 0.8   |                |   |
| 8  | 39.500   | 9.1   | 1.6516         |   | 23 | 21.047  | 1.2   |                |   |
| 9  | -260.753 | 0.1   |                |   | 24 | ∞       | 9.0   |                |   |
| 10 | 52.824   | 3.0   | 1.6516         |   | 25 | ∞       | 9.8   |                |   |
| 11 | 90.946   | *** 1 |                |   | 26 | 148.995 | 6.9   |                |   |
| 12 | 345.300  | 1.0   | 1.717          |   | 27 | -19.704 | 0.4   |                |   |
| 13 | 16.261   | 5.4   |                |   | 28 | 18.900  | 4.9   |                |   |
| 14 | -30.253  | 0.7   | 1.5168         |   | 29 | -14.290 | 1.2   |                |   |
| 15 | 18.200   | 3.7   | 1.72825        |   | 30 | 34.322  |       |                |   |

- (1) E.F.L=9.5  
 \*\*\* 1 = 1.8144; \*\*\* 2 = 39.4096; \*\*\* 3 = 1.8788  
 (2) E.F.L=50.0  
 \*\*\* 1 = 27.8144; \*\*\* 2 = 2.0358; \*\*\* 3 = 13.2526

● 原资料不全, 仅供参考。

